



MODEL CMA-180UC

PARTS MANUAL

Rev 1.20C 03-2024



CMA DISHMACHINES
12700 KNOTT AVENUE
GARDEN GROVE, CALIFORNIA 92841

800-854-6417

FAX 714-895-2141

www.cmadishmachines.com

[Buy Parts](#)

TABLE OF CONTENTS

MODEL CMA-180UC

1. PARTS MANUAL	3
1.1. INITIAL PARTS KIT (P/N 1100.66).....	3
1.2. DRAIN PUMP	4
1.3. DRAIN PUMP REMOVAL INSTRUCTIONS	5
1.4. MECHANICAL DRAWINGS.....	6
1.4.1. Cabinet Assembly.....	6
1.4.2. Door Assembly.....	7
1.4.3. Electrical Tray.....	8 & 9
1.4.4. Control Box Assembly p/n 18611.61	10 & 11
1.4.5. Control Box Assembly p/n 18611.61.....	12
1.4.6. Chemical Dispenser Assembly	13
1.4.7. Chemical Dispenser Assembly P/N 14585.00 (Optional).....	14 & 15
1.4.1. Plumbing System Assembly (Effective April 2018)	16
1.4.2. Plumbing System Assembly (Effective April 2012)	17
1.4.3. Plumbing System Assembly.....	18
1.4.4. Drain System Assembly.....	19
1.4.5. Wash System	20
1.4.6. Rinse System	21
1.4.7. S/S Pump Assembly (Effective August 2009)	22
1.4.8. Pump System Assembly.....	23
1.4.9. Old Heater Assembly (Square Flange)	24
1.4.10. New Heater Assembly (Triangular Flange).....	25 & 26
1.4.11. Drain Valve.....	27
1.4.12. Drain Valve (Effective January 2011)	28
1.4.13. Water Tempering Kit (Optional).....	29 & 30



1. Parts Manual

1.1. Initial Parts Kit (P/N 1100.66)

P/N	DESCRIPTION	Qty
15504.00	Motor Contactor, 2-Pole 20 Amp	1
15504.50	Heater Contactor, 2-Pole 35 Amp	1
00501.00	2-Minute Timer Motor	1
00631.00	Ice Cube Relay 120 V	1
15523.00	Rocker Switch Start Momentary	1
15523.50	Rocker Switch Drain/Fill	1
15524.00	Rocker Switch Power Maintained	1
00556.10	Reed Switch	1
03623.00	1/2" Vacuum Breaker Repair Kit – Watts	1
04113.00	L1X/L1-C Drain Valve 120V	1
00206.70	Pump Seal Kit	1
13417.89	Heater Thermostat	1
17523.60	High Limit Switch 200°F	1
00411.00	Microswitch	1
03203.01	Dual Temperature Display Kit	1
00707.00	1/2 Water Solenoid Repair Kit JE	1
00706.00	3/4 Water Solenoid Repair Kit JE	1
00738.10	Solenoid Coil JE115V/60Hz	1

1.2. Drain Pump

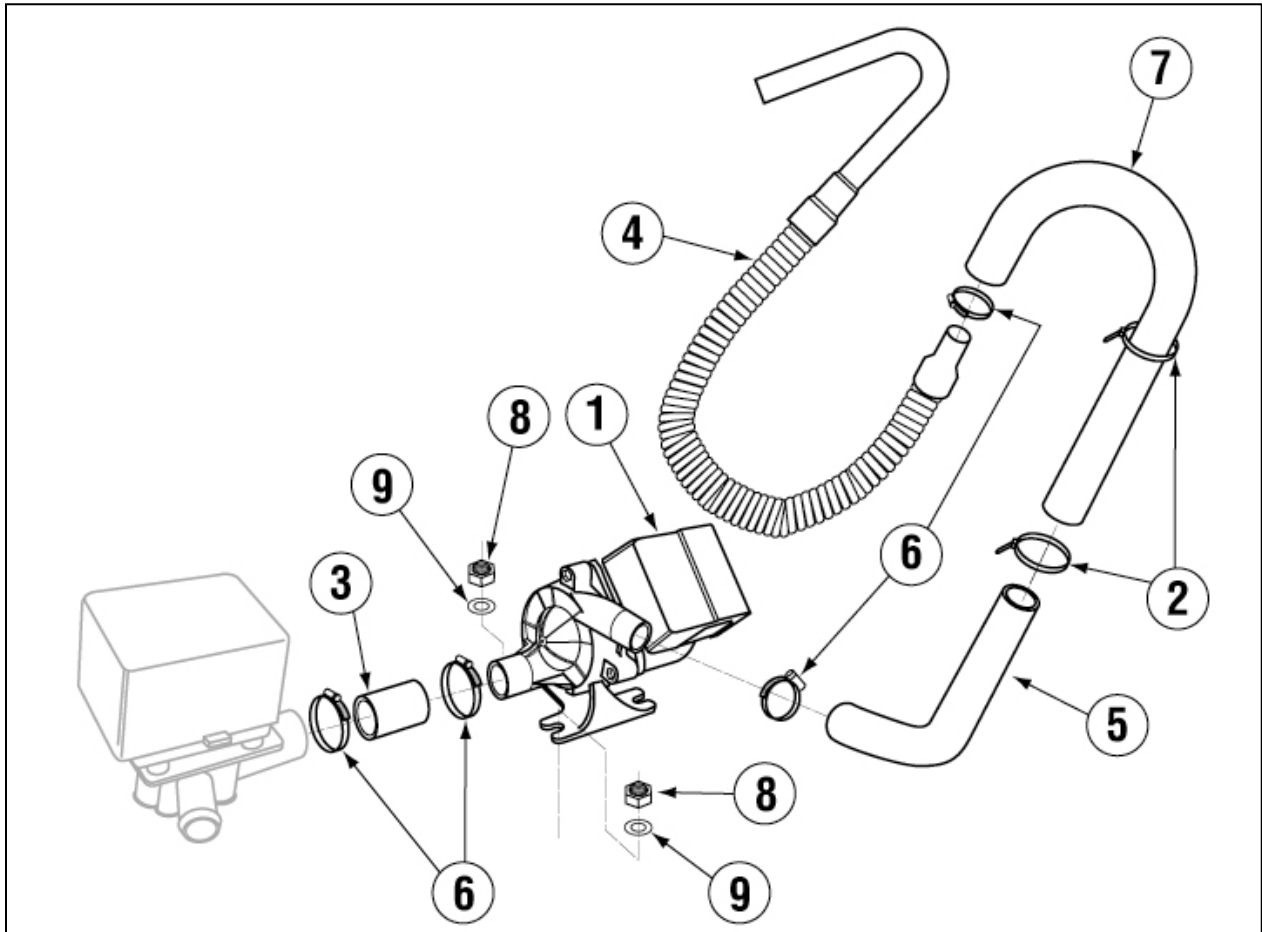

ITEM NO.	NO. REQ'D	P/N	DESCRIPTION
1	1	15503.00	Drain Motor Ultra Jet for CMA-180UC
2	2	00932.50	Twist Tie
3	1	15601.10	Black Drain Hose 1" ID X 3 1/2"
4	1	15605.00	Drain Hose with Goose Neck
5	1	15601.60	Hose 1" ID 14" 90Deg

ITEM NO.	NO. REQ'D	P/N	DESCRIPTION
6	4	03101.00	Hose Clamp 1"
7	1	15603.00	Drain Line Gooseneck
8	2	03801.10	10-32 SS Nut
9	2	04806.00	#10 Brass Washer

1.3. Drain Pump Removal Instructions

Drain Pump (P/N 15503.00) should only be used if a floor drain is not accessible to the machine at installation.

When converting the UC-180 dishwasher to a gravity drain unit, remove the drain pump assembly as shown in **Figure 1**. Re-route the 6Ft drain hose to the center port were the drain pump was located, moving the displaced line to the open port of the valve. Insure there is a 1" air gap between the discharge and floor drain as shown in **Figure 2**.

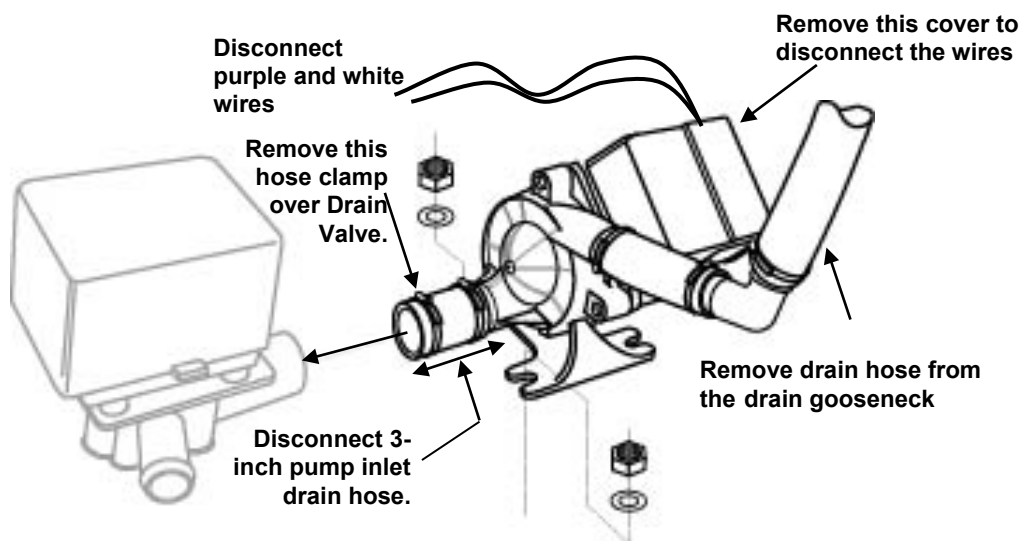

Figure 1

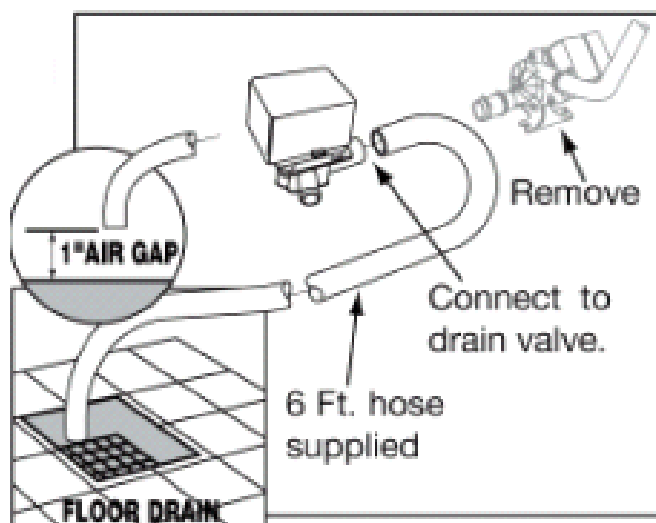
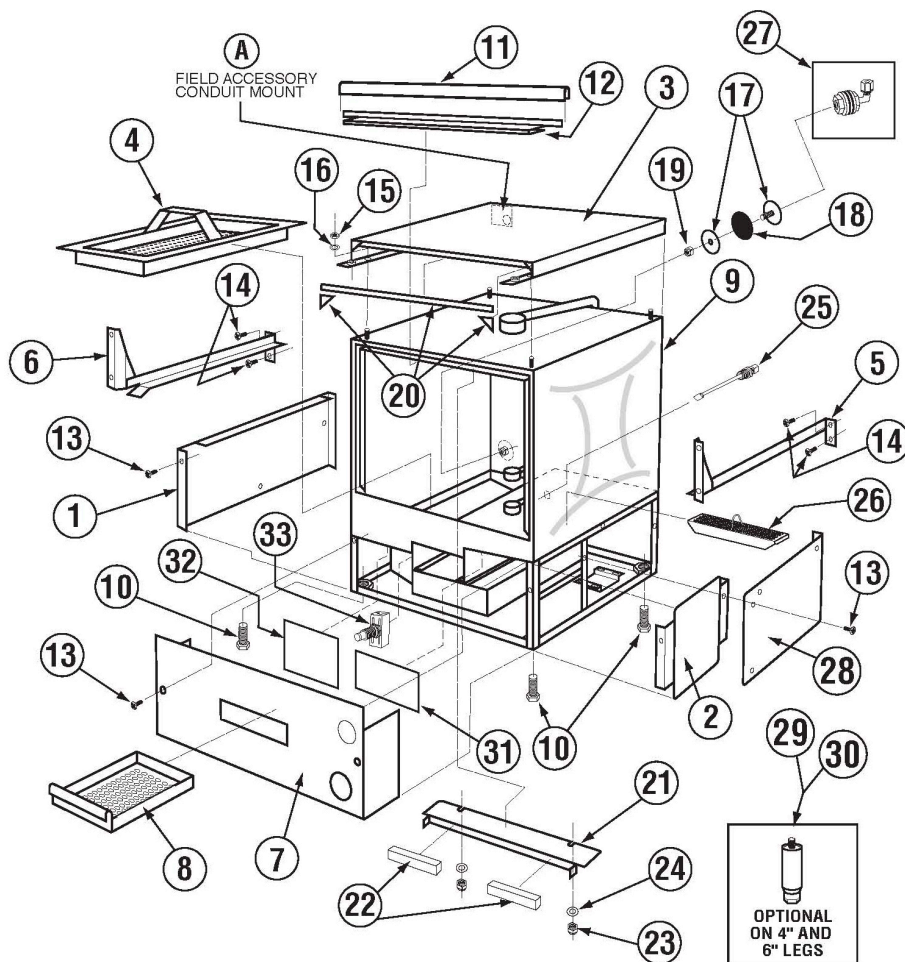

Figure 2.

1.4. Mechanical Drawings

1.4.1. Cabinet Assembly



ITEM NO.	NO. REQ'D	P/N	DESCRIPTION
1	1	14502.82	Side Panel L.H. for CMA-180UC
2	1	14508.10	Peri Pump Front R Side Cover(180-UC)
3	1	14503.40	SS Top for CMA-180UC
4	1	14510.00	Scrap Basket for CMA-180UC
5	1	14511.00	Tray Track R.H. for CMA-180UC
6	1	14512.00	Tray Track L.H. for CMA-180UC
7	1	14515.00	Lower Front Panel for CMA-180UC
8	1	14560.20	Scrap Tray Drawer for CMA-180UC
9	1	14501.20	SS Body for CMA-180UC
10	4	01310.60	Leg Adjusters for CMA-180UC *
11	1	14506.50	Door Gasket for CMA-180UC
12	1	14506.45	Gasket Bracket for CMA-180UC
13	6	00940.50	10-32 x 3/8 Trusshead Screw
14	8	00941.00	10-32 x 5/8 Panhead Screw
15	4	03801.00	10-32 Lock Nut
16	4	00940.51	#10 Internal Lock Star Washer
17	1	01513.00	Detergent Injection Hole Plug

ITEM NO.	NO. REQ'D	P/N	DESCRIPTION
18	1	00752.00	Detergent Injection Hole Plug Gasket
19	1	00912.00	1/4"-20 Nylon Lock Nut
20	2ft	03705.84	Control Box Gasket for CMA-180UC
21	1	14558.00	Body Magnet Holder for CMA-180UC
22	2	00557.80	Magnet for CMA-180UC
23	2	00927.00	8-32 Lock Nut
24	2	04806.00	#10 Brass Flat Washer
25	1	03204.50	Thermo well Ass'Y Cma-180UC (Wash)
26	1	14561.00	Scrap Trap Filter (CMA 180-UC)
27	1	03415.00	Chemical Bulk Head
28	1	14508.20	Peri Pump Back R Side Cover(180-UC)
29	4	01147.50	Leg 4" 1/2-13 1" Diameter (UC)
30	4	01147.00	^Leg 6" 1/2"-13 1" Diameter (UC)
31	1	03705.21	Timer Splash Shield Mylar
32	1	03705.25	Heater Splash Shield Mylar
33	1	03475.00	Booster Fill Switch - Push Button *

*Effective February 2018

1.4.2. Door Assembly

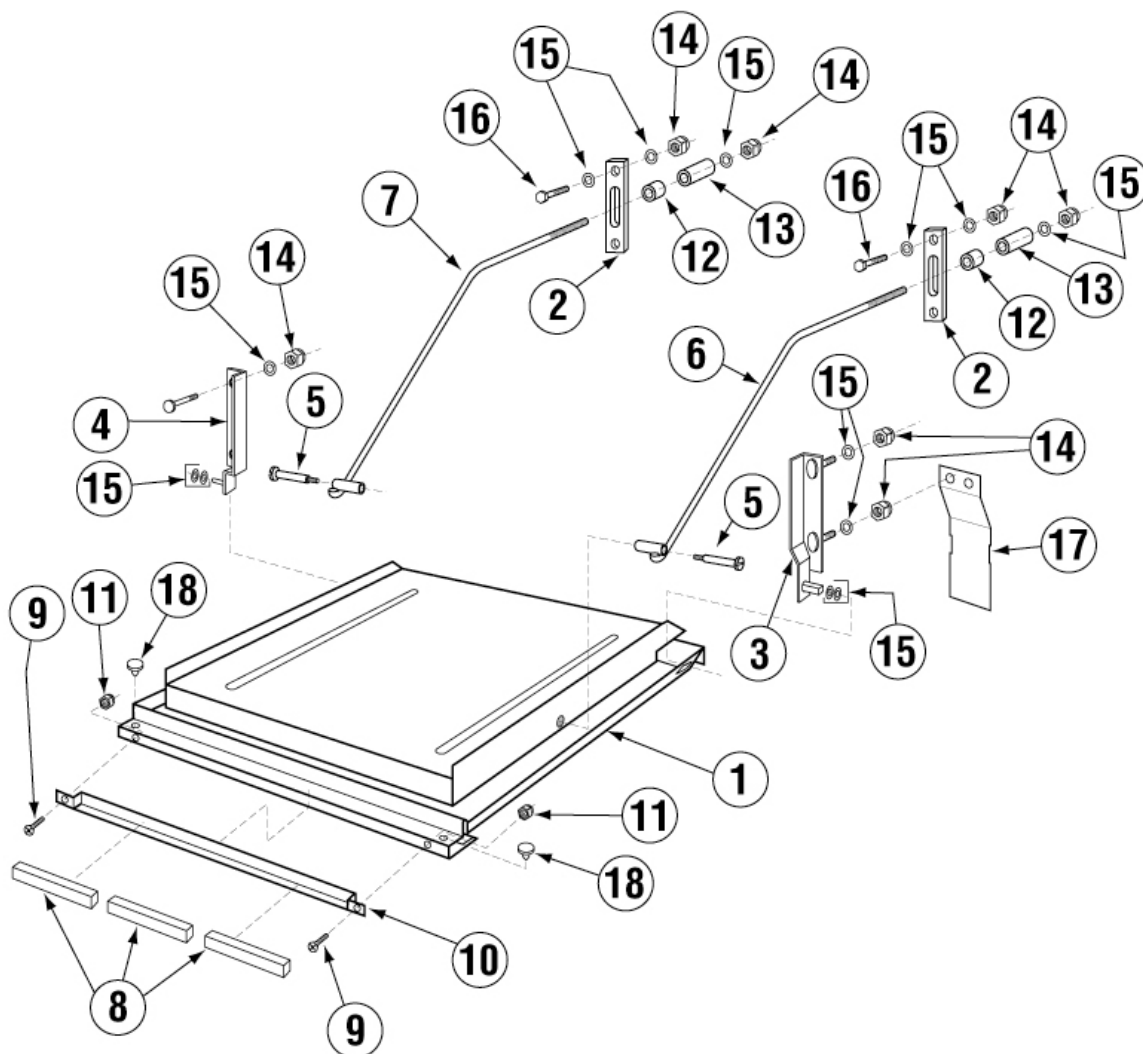

ITEM NO.	NO. REQ'D	P/N	DESCRIPTION
1	1	14506.00	Door for CMA-180UC
2	2	04517.60	Door Support Rod Block
3	1	14570.00	Door Hinge R.H. for CMA-180UC
4	1	14570.50	Door Hinge L.H. for CMA-180UC
5	2	04919.00	Door Rod Screw Pin for CMA-180UC
6	1	04918.60	Door Support Rod Right
7	1	04919.50	Door Support Rod Left
8	3	00557.80	Door Magnet
9	2	00970.60	6-32 x 1/2" Flathead Screw

ITEM NO.	NO. REQ'D	P/N	DESCRIPTION
10	1	14558.61	Door Magnet Holder for CMA-180UC
11	2	00965.00	6-32 Lock Nut
12	2	00605.20	Door Rod Spacer
13	2	04517.15	Door Stop (Parallel)
14	10	00912.00	1/4"-20 Nylon Lock Nut
15	14	00924.00	1/4" SS Washer
16	4	00914.10	1/4"-20 x 5/8" Hexhead Bolt
17	2	14518.00	Splash Guard
18	2	00605.00	Door Handle Button-Undercounters

Parts Manual

1.4.3. Electrical Tray

Effective January 2021

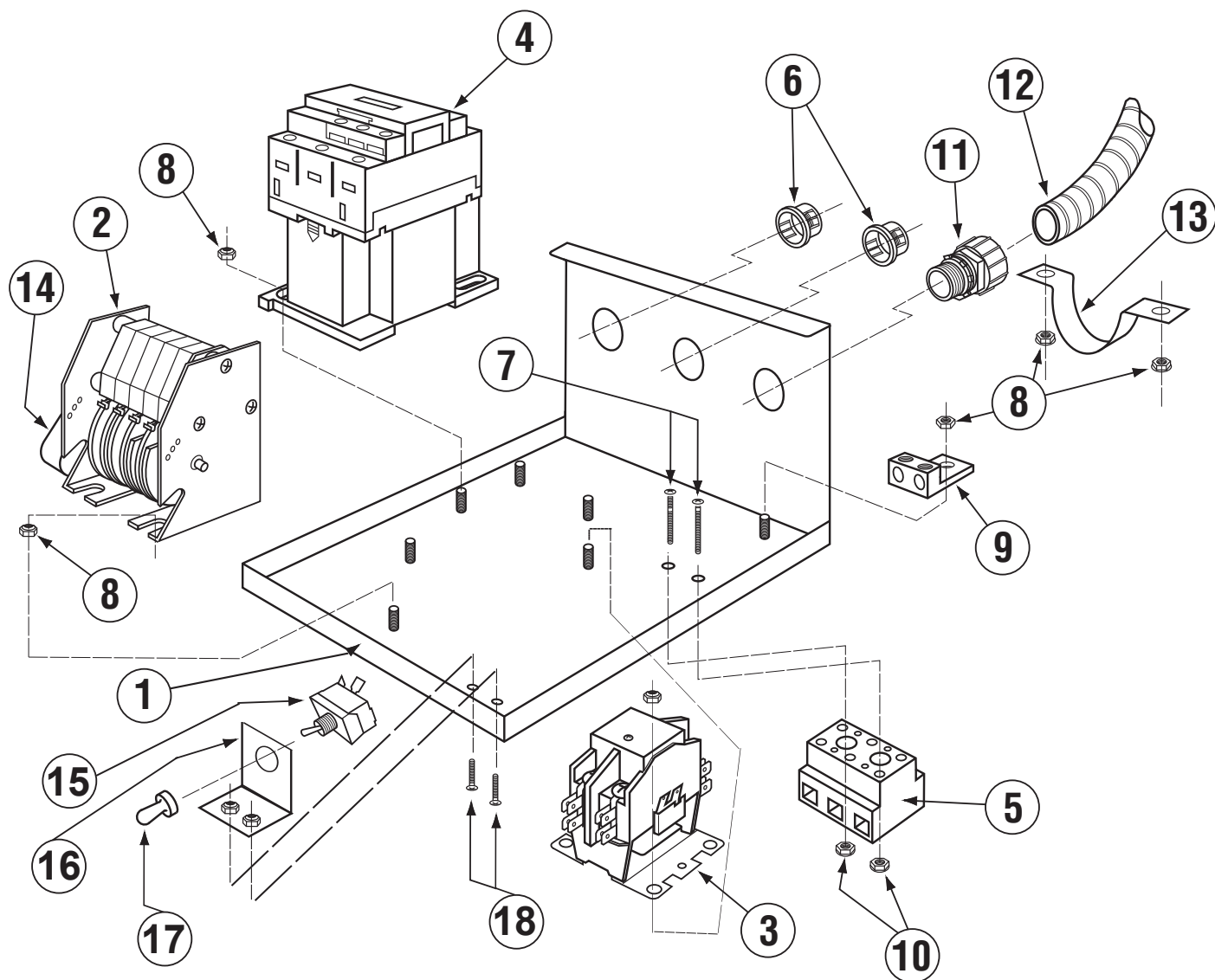

ITEM NO.	NO. REQ'D	P/N	DESCRIPTION
1	1	14504.00	Electrical Tray for CMA-180UC
2	1	14408.87	Timer 2 Min 7 Cam 180-UC S.T
3	1	15504.00	Motor Contactor, 2-Pole 20 Amp
4	1	15504.50	Heater Contactor, 2-Pole 35 Amp
5	1	15520.50	Power Block, 3-Position
6	2	00438.00	Snap Bushing, Universal
7	2	01001.00	6-32 x 1" Panhead Screw
8	12	00927.00	8-32 Nylon Lock Nut
9	1	13426.60	Ground Block

ITEM NO.	NO. REQ'D	P/N	DESCRIPTION
10	2	00965.00	6-32 Lock Nut
11	1	00401.85	3/4" Conduit Connector, Straight
12	9	00400.85	3/4" Conduit, Sealtite
13	1	00401.85	HT Plumbing Bracket
14	1	00400.85	Timer Motor
15	1	00471.10	Toggle Switch DPST 20A
16	1	00474.00	Toggle Switch Bracket
17	1	00470.10	Toggle Switch Rubber Boot
18	2	00907.00	6-32 x 1/2" Panhead Screw

1.4.3. Electrical Tray

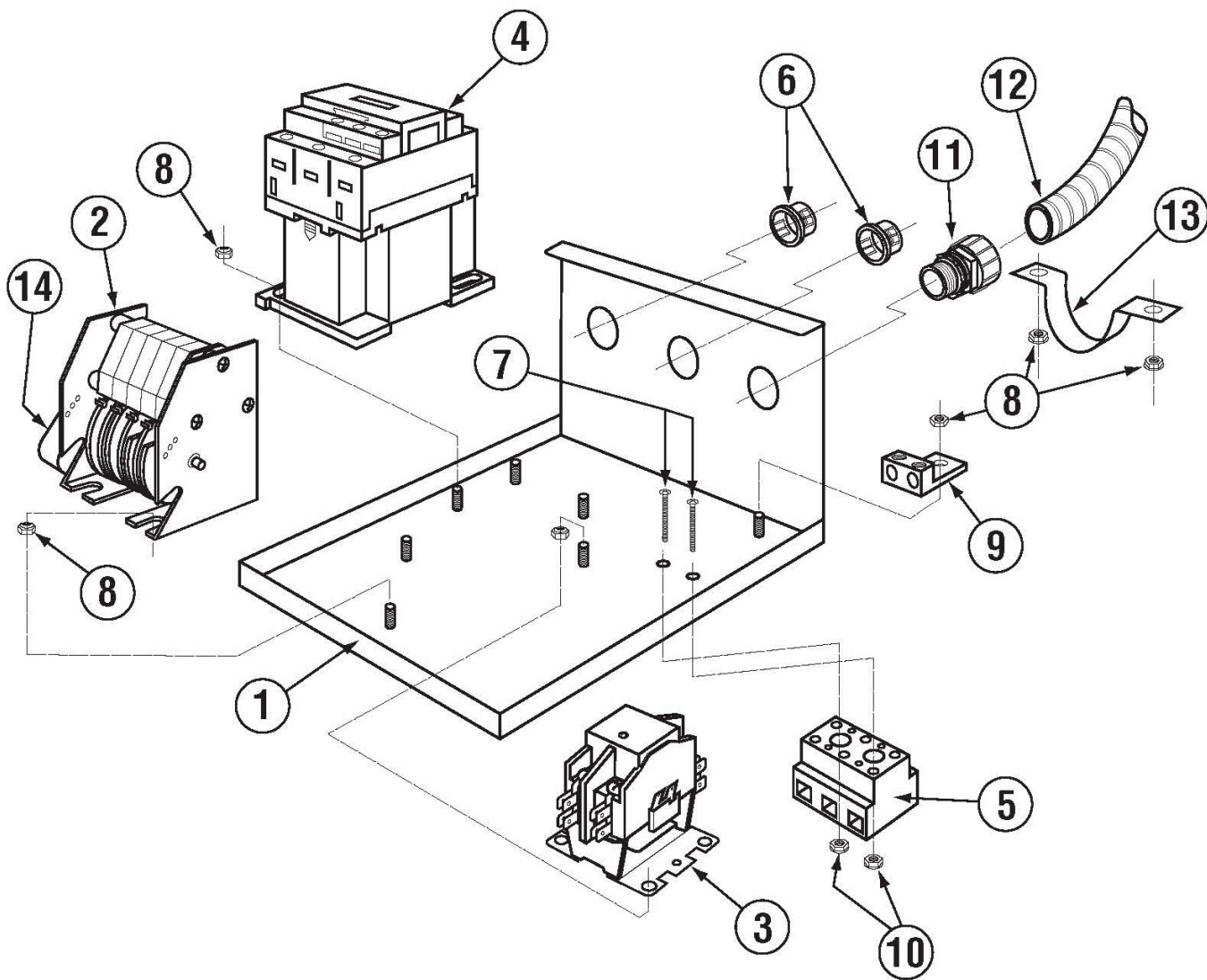

ITEM NO.	NO. REQ'D	P/N	DESCRIPTION
1	1	14504.00	Electrical Tray for CMA-180UC
2	1	14408.81	Timer 2Min 5 Cam 180-UC S.T
3	1	15504.00	Motor Contactor, 2-Pole 20 Amp
4	1	15504.50	Heater Contactor, 2-Pole 35 Amp
5	1	15520.50	Power Block, 3-Position
6	2	00438.00	Snap Bushing, Universal
7	2	01001.00	6-32 x 1" Panhead Screw

ITEM NO.	NO. REQ'D	P/N	DESCRIPTION
8	12	00927.00	8-32 Nylon Lock Nut
9	1	13426.60	Ground Block
10	2	00965.00	6-32 Lock Nut
11	1	00401.85	3/4" Conduit Connector, Straight
12	9	00400.85	3/4" Conduit, Sealtite
13	1	13304.61	HT Plumbing Bracket
14	1	00501.00	Timer Motor

Parts Manual

1.4.4. Control Box Assembly PN18611.61

Effective January 2020

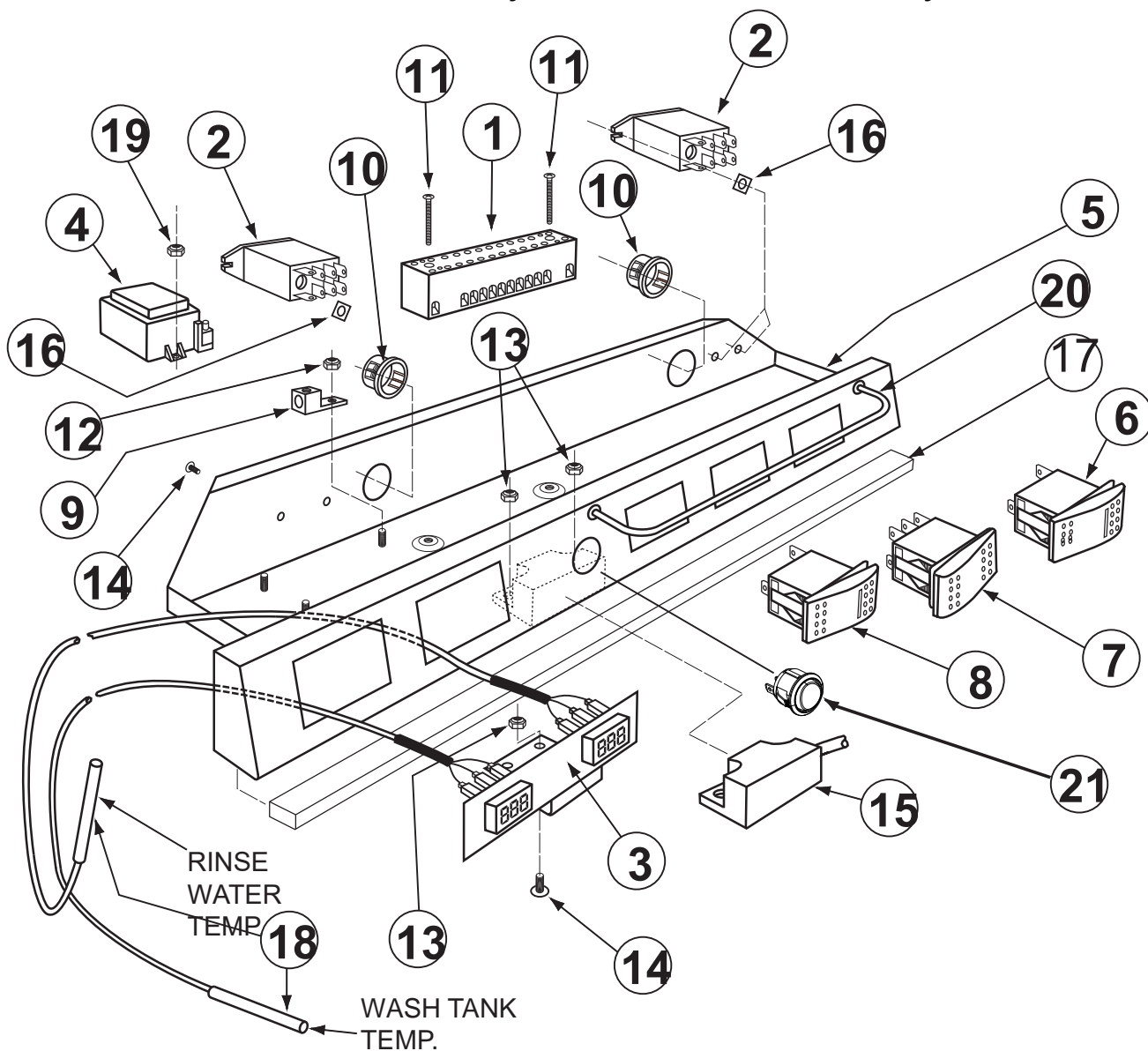

ITEM NO.	NO. REQ'D	P/N	DESCRIPTION
1	1	15520.00	Power Block 12-Position
2	2	00631.00	Ice Cube Relay 120 V
3	1	03203.01	Dual Temperature Display Kit
4	1	03202.60	Thermometer Transformer
5	1	14503.00	Control Drawer for CMA-180UC
6	1	15523.00	Rocker Switch Start Momentary
7	1	15523.50	Rocker Switch Drain Momentary
8	1	15524.00	Rocker Switch Power Maintained
9	1	13426.50	Ground Block
10	2	00438.00	Snap Bushing, Universal
11	2	01001.00	6-32 x 1" Panhead Screw

ITEM NO.	NO. REQ'D	P/N	DESCRIPTION
12	2	00965.00	6-32 SS Nylon Lock Nut
13	5	00927.00	8-32 Nylon Lock Nut
14	6	00911.00	8-32 x 1/2" Panhead Screw
15	1	00556.10	Reed Switch
16	4	00917.00	8-32 PM Nut
17	2	03705.82	Sponge Strip
18	2	03202.66	Thermocouple
19	2	00971.10	4-40 Nylon Lock Nut
20	1	03485.00	Switch Guard (Undercounter)
21	1	02103.57	Prime Switch
---	1	06232.62	180UC Panel Label w/ Prime (not shown)

1.4.4. Control Box Assembly

Effective April 2018

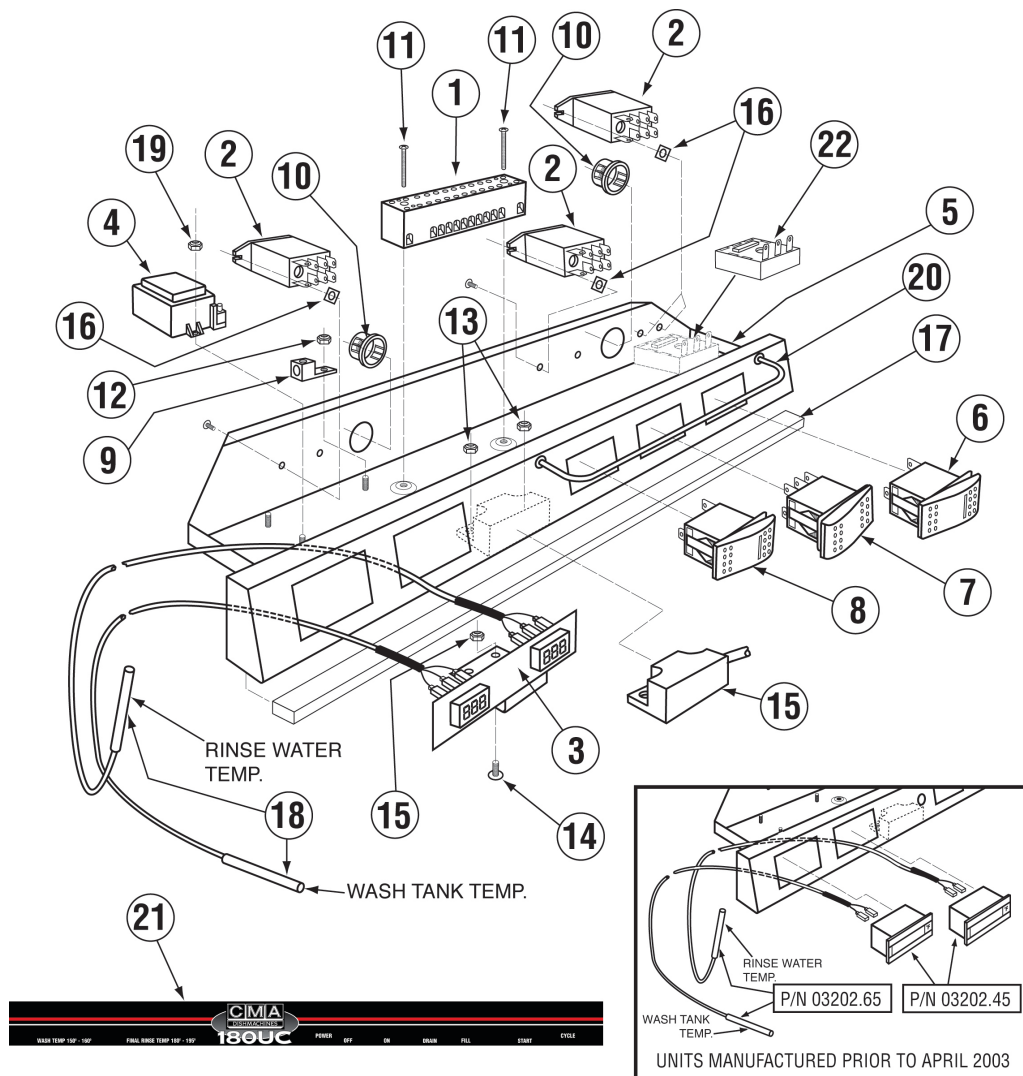

ITEM NO.	NO. REQ'D	P/N	DESCRIPTION
1	1	15520.00	Power Block 12-Position
2	3	00631.00	Ice Cube Relay 120 V
3	1	03203.01	Dual Temperature Display Kit
4	1	03202.60	Thermometer Transformer
5	1	14503.00	Control Drawer for CMA-180UC
6	1	15523.00	Rocker Switch Start Momentary
7	1	03481.00	Rocker Switch Drain Momentary
8	1	15524.00	Rocker Switch Power Maintained
9	1	13426.50	Ground Block
10	1	00438.00	Snap Bushing, Universal
11	2	01001.00	6-32 x 1" Panhead Screw

ITEM NO.	NO. REQ'D	P/N	DESCRIPTION
12	2	00965.00	6-32 SS Nylon Lock Nut
13	5	00927.00	8-32 Nylon Lock Nut
14	6	00911.00	8-32 x 1/2" Panhead Screw
15	1	00556.10	Reed Switch
16	4	00917.00	8-32 PM Nut
17	2	03705.82	Sponge Strip
18	2	03202.66	Thermocouple
19	2	00971.10	4-40 Nylon Lock Nut
20	1	03485.00	Switch Guard (Undercounter)
21	1	06232.62	180UC Panel Label Drain
22	1	00630.50	Timer Relay 120V

1.4.5. Control Box Assembly

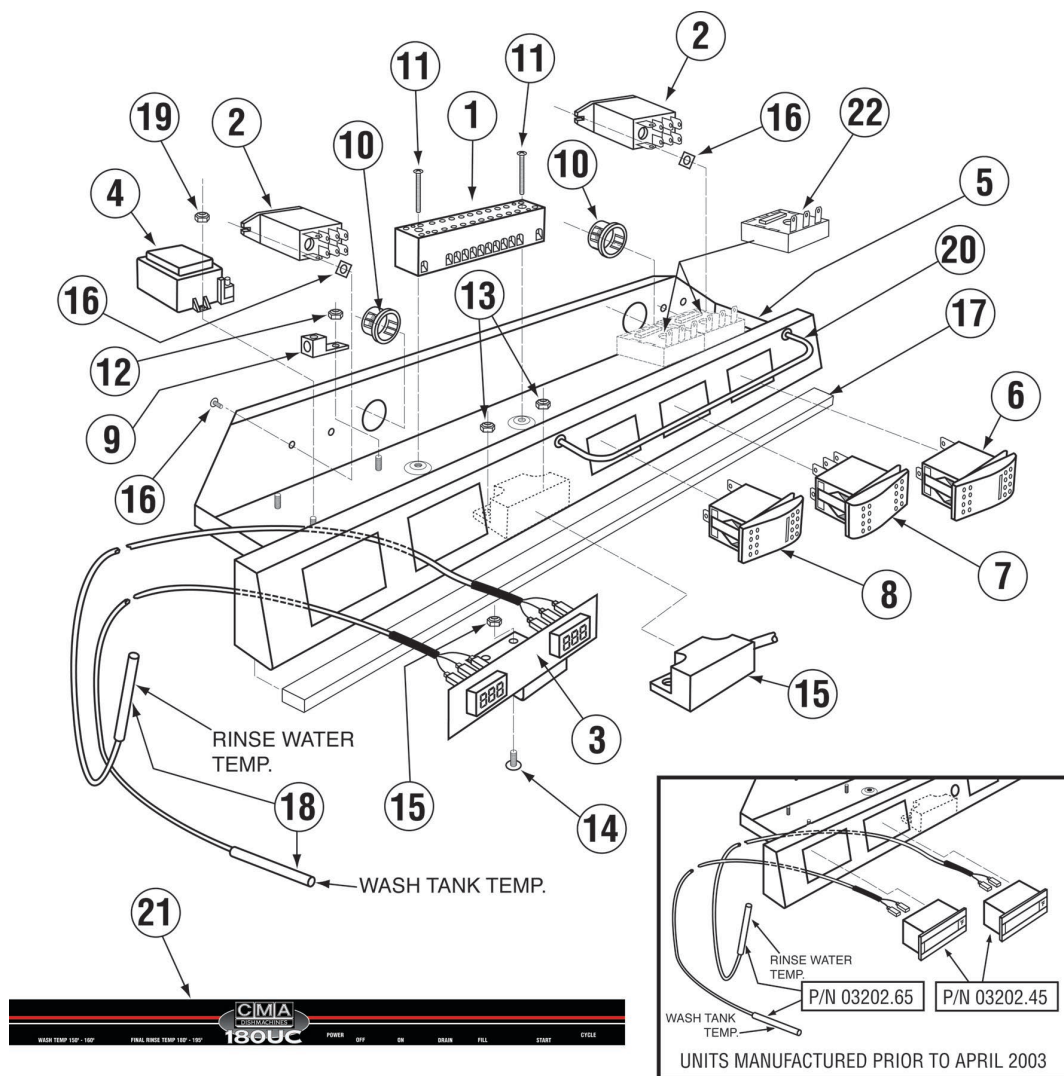

ITEM NO.	NO. REQ'D	P/N	DESCRIPTION
1	1	15520.00	Power Block 12-Position
2	2	00631.00	Ice Cube Relay 120 V
3	1	03203.01	Dual Temperature Display Kit
4	1	03202.60	Thermometer Transformer
5	1	14503.00	Control Drawer for CMA-180UC
6	1	15523.00	Rocker Switch Start Momentary *
7	1	15523.50	Rocker Switch Drain/Fill DPDT/Mom. *
8	1	15524.00	Rocker Switch Power Maintained *
9	1	13426.50	Ground Block
10	1	00438.00	Snap Bushing, Universal
11	2	01001.00	6-32 x 1" Panhead Screw

ITEM NO.	NO. REQ'D	P/N	DESCRIPTION
12	2	00965.00	6-32 SS Nylon Lock Nut
13	5	00927.00	8-32 Nylon Lock Nut
14	6	00911.00	8-32 x 1/2" Panhead Screw
15	1	00556.10	Reed Switch
16	4	00917.00	8-32 PM Nut
17	2	03705.82	Sponge Strip
18	2	03202.66	Thermocouple
19	2	00971.10	4-40 Nylon Lock Nut
20	1	03485.00	Switch Guard (Undercounter)
21	1	06232.61	180UC Panel Label Drain/Fill
22*	2	00630.50	Timer Relay 120V

* Effective January 2017

1.4.6. Chemical Dispenser Assembly

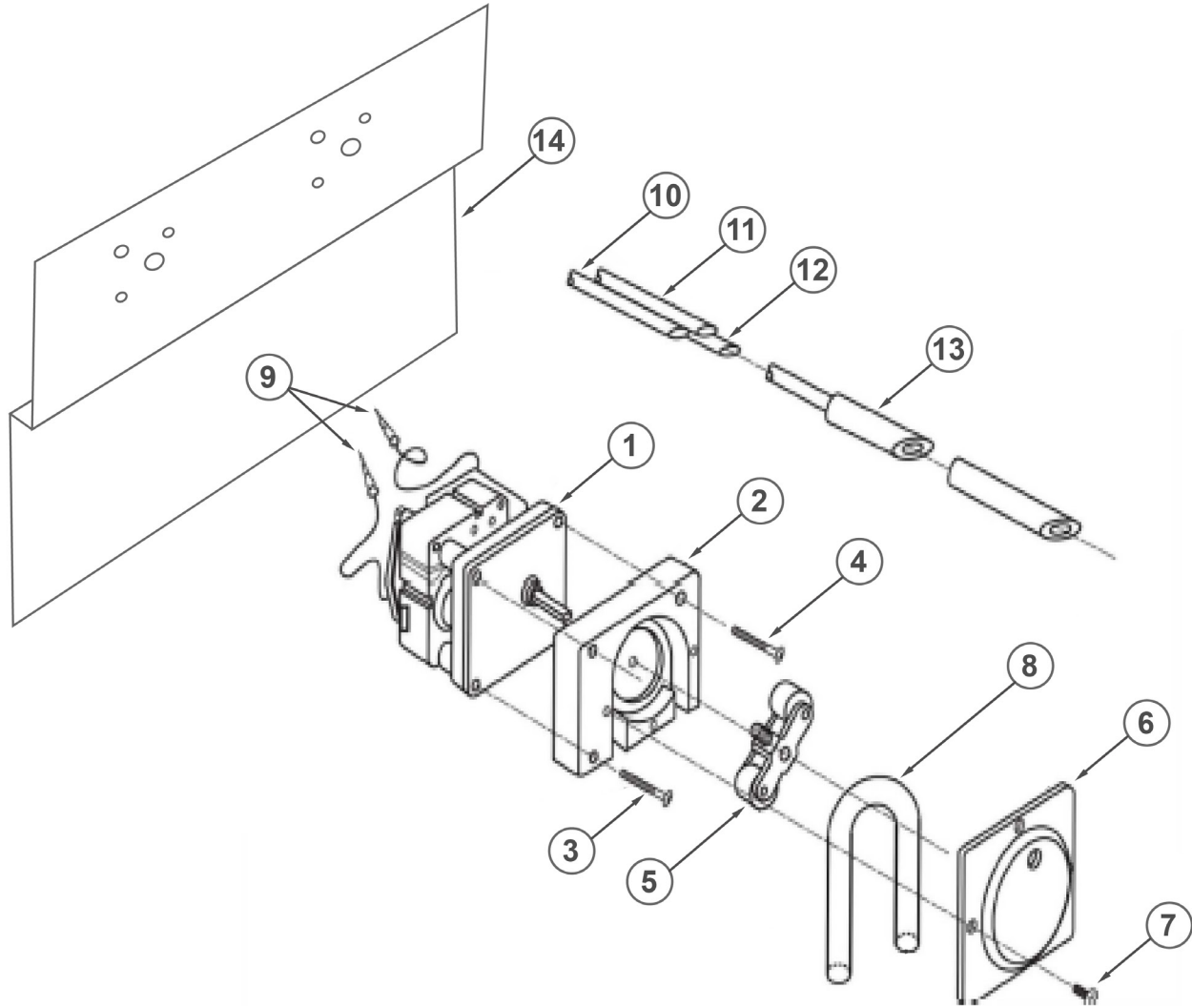

ITEM NO.	NO. REQ'D	P/N	DESCRIPTION
1	1	00416.00	Peristaltic Pump Motor
2	1	00417.10	Peristaltic Pump Block
3	1	00919.00	10-32x1-1/2" Pan Head Screw
4	1	00918.00	10-32x1-1/2" Fillister Head Screw
5	1	00419.00	Peristaltic Pump Rotor
6	1	00418.00	Peristaltic Pump Cover
7	1	00911.00	8-32x1/2" Pan Head Screw

ITEM NO.	NO. REQ'D	P/N	DESCRIPTION
8	1	02257.23	Squeeze Tube 11"
9	1	00448.00	Barrel Connector, Male
10	1	00425.23	Chemical Tubing, Red, 50 Ft Roll
11	1	00425.21	Chemical Tubing, Blue, 50 Ft Roll
12	1	00425.24	Chemical Tubing, White, 50 Ft Roll
13	1	00443.00	Tube Stiffener
14	1	14508.40	180UC Peri Pump Mount

1.4.7.1. Chemical Dispenser Assembly P/N 14585.00 (Optional)

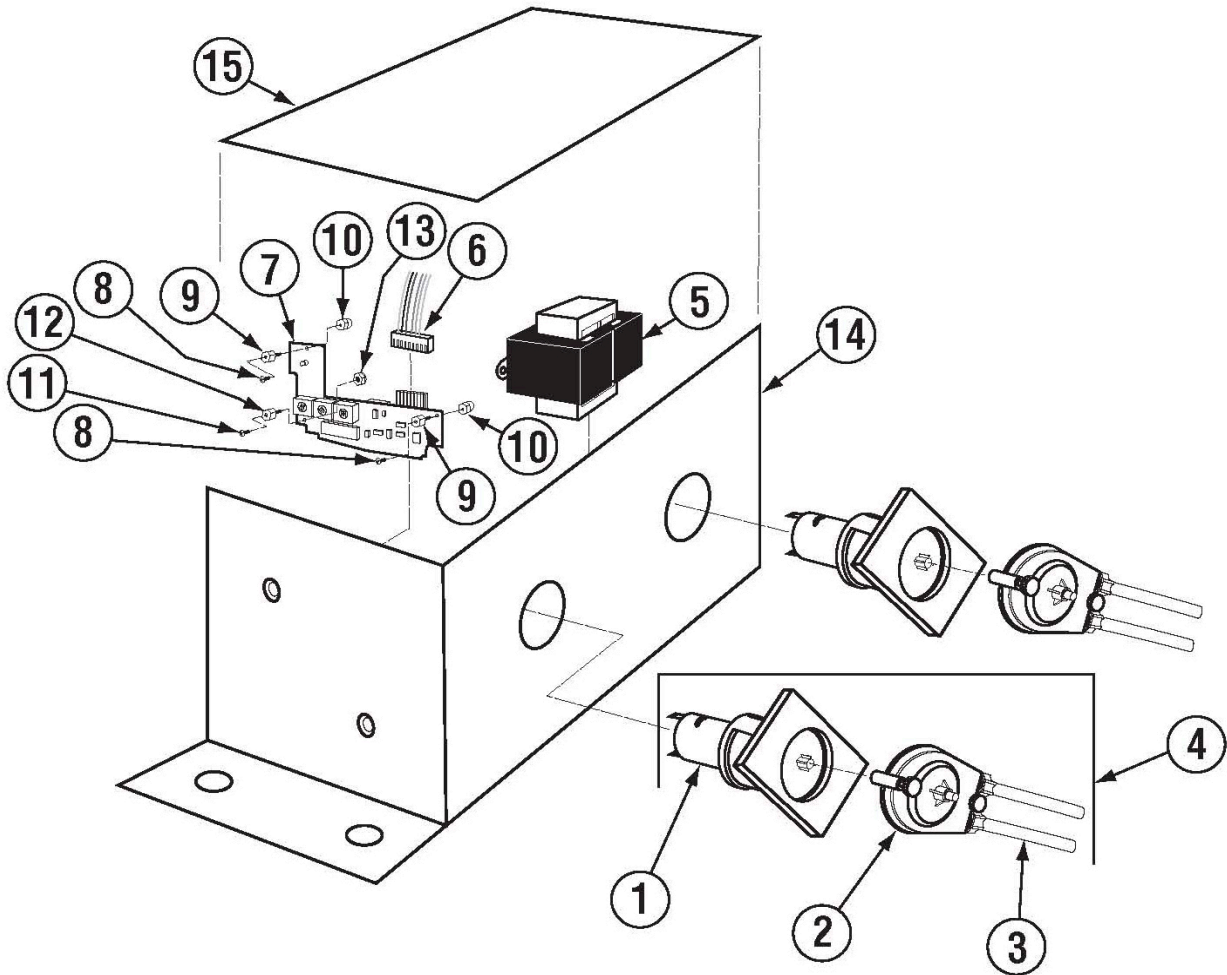

ITEM NO.	NO. REQ'D	P/N	DESCRIPTION
1	2	00816.00	Peri Pump Gear Motor (GL-C/GW-100)
2	2	00818.00	GL-C/GW-100 Peri Pump Cartridge
3	2	00839.00	GL-C/GW-100/UC180 Sqz Tube Clear
	2	00835.30	GL-C/GW-100/UC180 Sqz Tube Black
4	2	00815.00	GL-C Peri Pump Complete
5	1	00821.10	GL-C/GW-100 Transformer
6	2	00820.40	Circuit Board Connector
7	2	00820.00	GL-C/GW-100 Peri Pump Circuit Board

ITEM NO.	NO. REQ'D	P/N	DESCRIPTION
8	4	13826.47	4-40 x 3/16 Phil Pan Head Screw
9	4	00820.06	Circuit Board Standoff
10	4	00820.07	Circuit Board Standoff Cap
11	2	13826.00	4-40 X 5/8 Pan Head Screw
12	2	00820.50	Circuit Board Stand-off Bushing
13	2	00971.10	4-40 Nylon Lock Nut
14	1	14508.00	UC180 Peri Pump Box
15	1	14585.73	Dispenser Splash Shield

*Effective May 2019

1.4.7.2. Chemical Dispenser Assembly P/N 14585.00 (Optional)

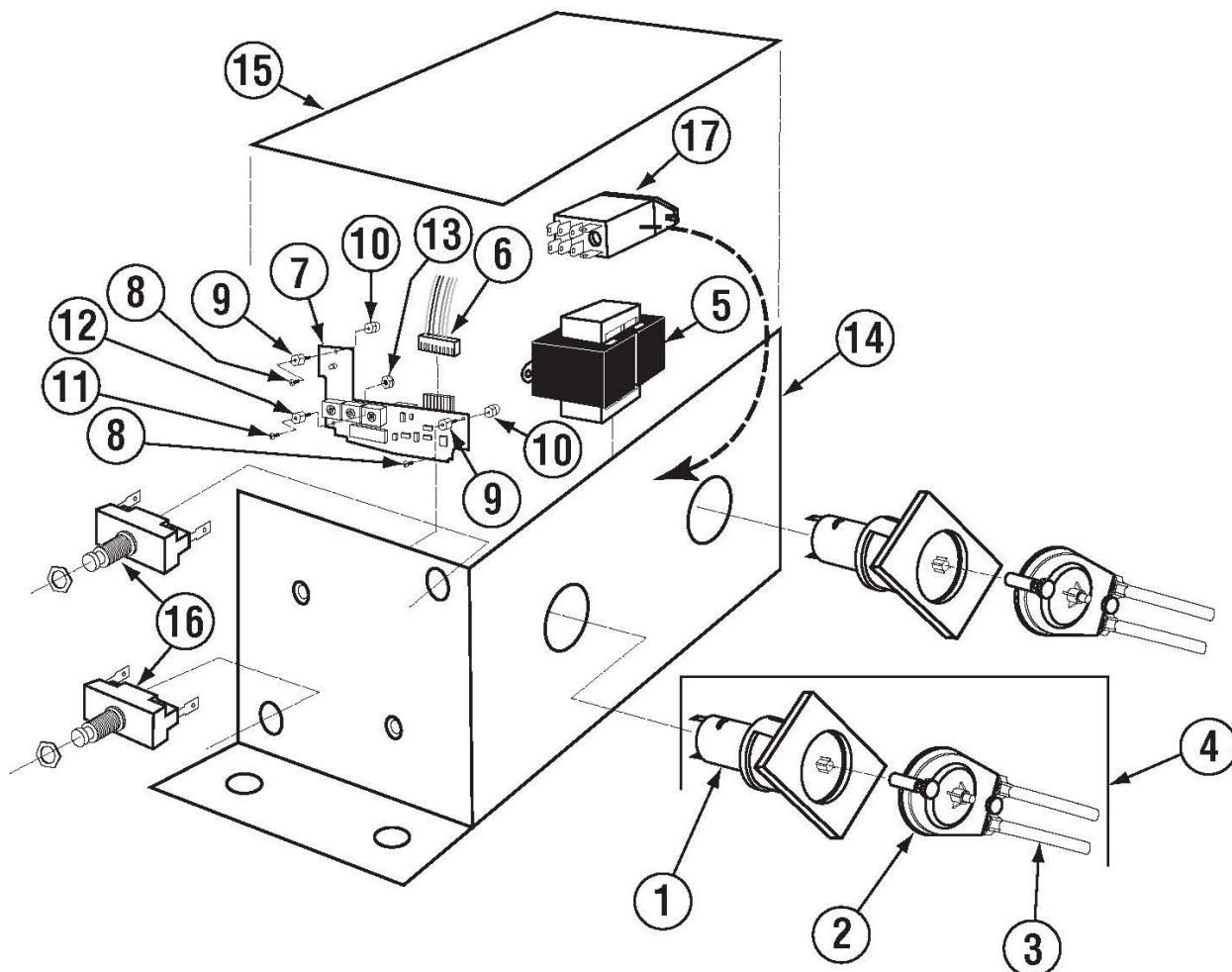

ITEM NO.	NO. REQ'D	P/N	DESCRIPTION
1	2	00816.00	Peri Pump Gear Motor (GL-C/GW-100)
2	2	00818.00	GL-C/GW-100 Peri Pump Cartridge
3	2	00839.00	GL-C/GW-100/UC180 Sqz Tube Clear
	2	00835.30	GL-C/GW-100/UC180 Sqz Tube Black
4	2	00815.00	GL-C Peri Pump Complete
5	1	00821.10	GL-C/GW-100 Transformer
6	2	00820.45	Circuit Board Connector
7	2	00820.00	GL-C/GW-100 Peri Pump Circuit Board
8	4	13826.47	4-40 x 3/16 Phil Pan Head Screw

ITEM NO.	NO. REQ'D	P/N	DESCRIPTION
9	4	00820.06	Circuit Board Standoff
10	4	00820.07	Circuit Board Standoff Cap
11	2	13826.00	4-40 X 5/8 Pan Head Screw
12	2	00820.50	Circuit Board Stand-off Bushing
13	2	00971.10	4-40 Nylon Lock Nut
14	1	14508.00	UC180 Peri Pump Box
15	1	14585.73	Dispenser Splash Shield
16	1	14585.68	Dispenser Switch - UC 180 *
17	1	00631.00	Ice Cube Relay 120 V *

*Effective April 2018 to April 2019

Parts Manual

1.4.1. Plumbing System Assembly (Effective April 2018)

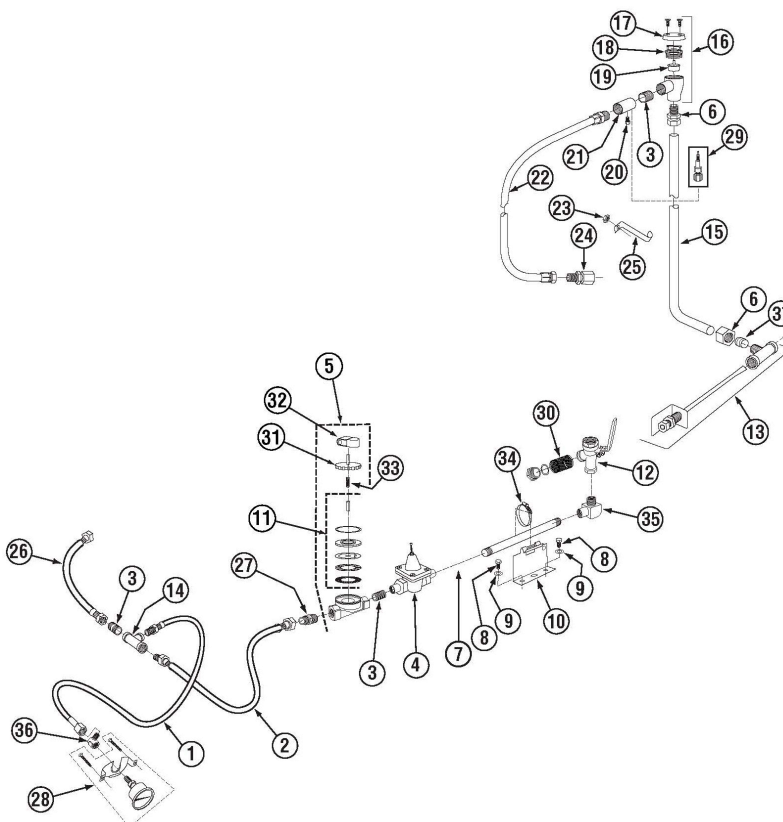

ITEM NO.	NO. REQ'D	P/N	DESCRIPTION
1	1	15602.00	SS Braided Hose 20"1/4 Comp x 1/2M
2	1	00798.00	SS Braided Hose 20"1/2 Comp X 1/2 M
3	2	03614.00	Nipple, Brass 1/2" Close
4	1	13602.27	Pressure Regulator 1/2"
5	1	00705.00	3/4 Water Sol Valve JE115V/60Hz
6	3	00770.10	5/8 Compression Fitting Nut
7	1	00747.10	Nipple Brass 1/2 x 5
8	2	00940.50	10-32 X 3/8 Truss Head Screw
9	2	03801.60	10-32 KEPS Lock Nut
10	1	14508.50	Plumbing Bracket
11	1	00706.00	3/4 Water Solenoid Repair Kit JE
12	1	41062.00	1/2" Strainer Ball Valves *
13	1	03205.00	Thermo well Tee
14	1	00743.10	1/2" T,FxFxF
15	1	05007.61	Vacuum Breaker Line
16	1	03624.00	1/2" Vacuum Breaker – Watts
17	1	00739.50	Vacuum Breaker Cap, SS
18	1	03624.25	Vacuum Breaker Bonnet, Brass
19	1	03623.00	1/2" Vac. Breaker Repair Kit – Watts

ITEM NO.	NO. REQ'D	P/N	DESCRIPTION
20	1	03232.00	1/8" Male Plug
21	1	13669.45	SS Mixing Chamber CMA-180UC
22	1	00798.00	1/2" SS Braided Hose
23	2	00915.00	1/4"-20 SS Nut
24	2	00724.00	1/2" Compression x 1/2" MIP Adapter
25	1	13304.53	Long Support Bracket
26	1	00798.40	SS Braided Hose 12" 1/2 x 1/2
27	1	00724.00	Adapter 1/2 Comp x 1/2 MIP
28	1	13605.45	Pressure Gauge for CMA-180UC
29	1	13658.00	Inlet Check Valve
30	1	41062.10	Ball Strainer
31	1	03603.20	1/2" Water Solenoid Valve Bonnet
32	1	00738.10	Solenoid Coil JE115V/60Hz
33	1	00706.10	Solenoid JE Spring Only
34	1	03101.45	Hose Clamp #4 Size #002 SS
35	1	00745.00	1/2 90Deg Street Elbow
36	1	40137.00	1/4 Street Elbow 90Deg
37	1	00710.20	5/8 Compression Fitting Ring

Parts Manual

1.4.2. Plumbing System Assembly (Effective April 2012)

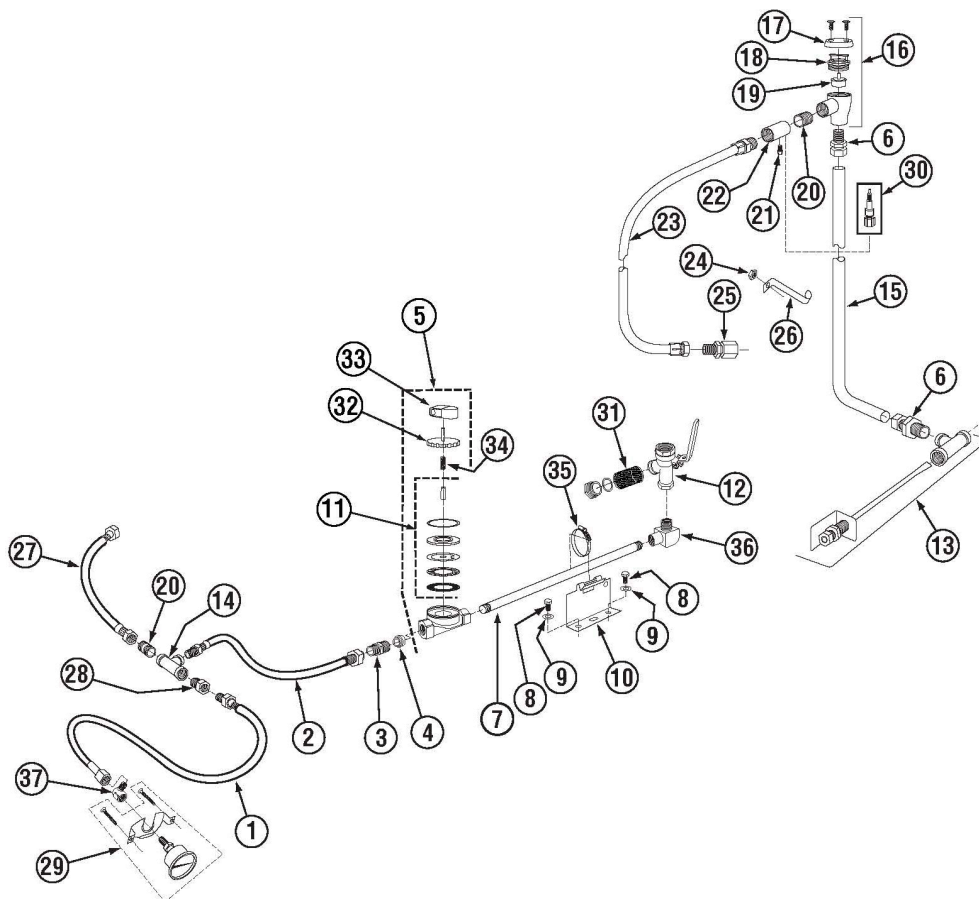

ITEM NO.	NO. REQ'D	P/N	DESCRIPTION
1	1	15602.00	SS Braided Hose 20"
2	1	00798.00	SS Braided Hose 20"
3	1	03604.50	Fitting with Flow Disk
4	1	03604.10	SS Solenoid Valve Flow Disc
5	1	03603.10	1/2 Water Sol Valve JE115V/60Hz
6	3	00760.00	5/8" Compression x 1/2" MIP Adapter
7	1	03605.20	Plumbing Tube
8	2	00940.50	10-32 X 3/8 Truss Head Screw
9	2	03801.60	10-32 KEPS Lock Nut
10	1	14508.50	Plumbing Bracket
11	1	00707.00	1/2 Water Solenoid Repair Kit JE
12	1	41062.00	1/2" Strainer Ball Valves *
13	1	03205.00	Thermo well Tee
14	1	00743.10	1/2" T,FxFxF
15	1	05007.61	Vacuum Breaker Line
16	1	03624.00	1/2" Vacuum Breaker – Watts
17	1	00739.50	Vacuum Breaker Cap, SS
18	1	03624.25	Vacuum Breaker Bonnet, Brass
19	1	03623.00	1/2" Vac. Breaker Repair Kit – Watts

ITEM NO.	NO. REQ'D	P/N	DESCRIPTION
20	2	03614.00	Nipple, Brass 1/2" Close
21	1	03232.00	1/8" Male Plug
22	1	13669.45	SS Mixing Chamber CMA-180UC
23	1	00798.00	1/2" SS Braided Hose
24	2	00915.00	1/4"-20 SS Nut
25	2	00724.00	1/2" Compression x 1/2" MIP Adapter
26	1	13304.53	Long Support Bracket
27	1	00798.40	SS Braided Hose 12"
28	1	13604.10	1/2 x 1/8 Bushing Brass
29	1	13605.45	Pressure Gauge for CMA-180UC
30	1	13658.00	Inlet Check Valve
31	1	41062.10	Ball Strainer
32	1	03603.20	1/2" Water Solenoid Valve Bonnet
33	1	00738.10	Solenoid Coil JE115V/60Hz
34	1	00706.10	Solenoid JE Spring Only
35	1	03101.45	Hose Clamp #4 Size #002 SS
36	1	00745.00	1/2 90Deg Street Elbow
37	1	40137.00	1/4 Street Elbow 90Deg

1.4.3. Plumbing System Assembly CMA-180UC PLUMBING SYSTEM ASSEMBLY

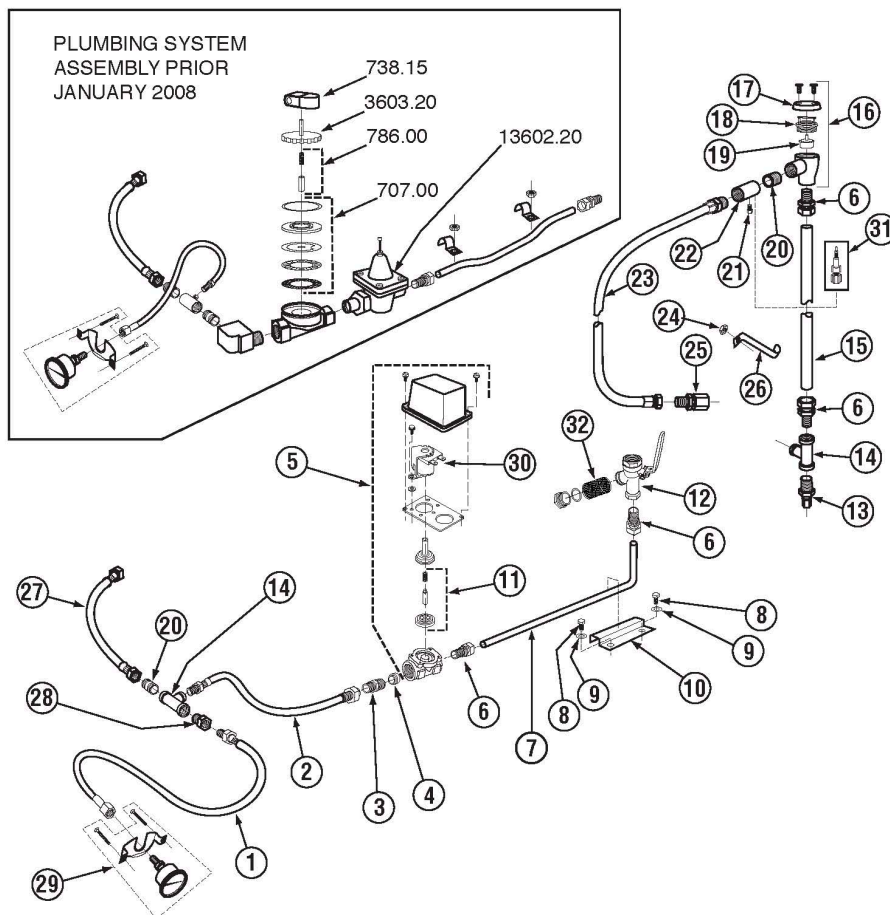

ITEM NO.	NO. REQ'D	P/N	DESCRIPTION
1	1	15602.00	SS Braided Hose 20"
2	1	00798.00	SS Braided Hose 20"
3	1	03604.50	Fitting with Flow Disk
4	1	03604.10	SS Solenoid Valve Flow Disc
5	1	03604.00	SS Water Solenoid Valve 1/2"
6	4	00760.00	5/8" Compression x 1/2" MIP Adapter
7	1	03605.00	Plumbing tube CMA-180UC
8	2	00940.50	10-32 X 3/8 Truss Head Screw
9	2	03801.60	10-32 KEPS Lock Nut
10	1	14508.60	Plumbing Bracket (180-UC)
11	1	03604.30	Dema Valve Repair Kit 1/2"
12	1	41062.00	1/2" Strainer Ball Valves *
13	1	00214.60	1/4" Compression x 1/2" MIP FTG
14	2	00743.10	1/2" T,FxFxF
15	1	05007.60	Vacuum Breaker Line
16	1	03624.00	1/2" Vacuum Breaker – Watts

ITEM NO.	NO. REQ'D	P/N	DESCRIPTION
17	1	00739.50	Vacuum Breaker Cap, SS
18	1	03624.25	Vacuum Breaker Bonnet, Brass
19	1	03623.00	1/2" Vac. Breaker Repair Kit – Watts
20	2	03614.00	Nipple, Brass 1/2" Close
21	1	03232.00	1/8" Male Plug
22	1	13669.45	SS Mixing Chamber CMA-180UC
23	1	00798.00	1/2" SS Braided Hose
24	2	00915.00	1/4"-20 SS Nut
25	2	00724.00	1/2" Compression x 1/2" MIP Adapter
26	1	13304.53	Long Support Bracket
27	1	00798.40	SS Braided Hose 12"
28	1	13604.10	1/2 x 1/8 Bushing Brass
29	1	13605.45	Pressure Gauge for CMA-180UC
30	1	41015.60	Water Solenoid Coil Only
31	1	13658.00	Inlet Check Valve
32	1	41062.10	Ball Strainer

1.4.4. Drain System Assembly

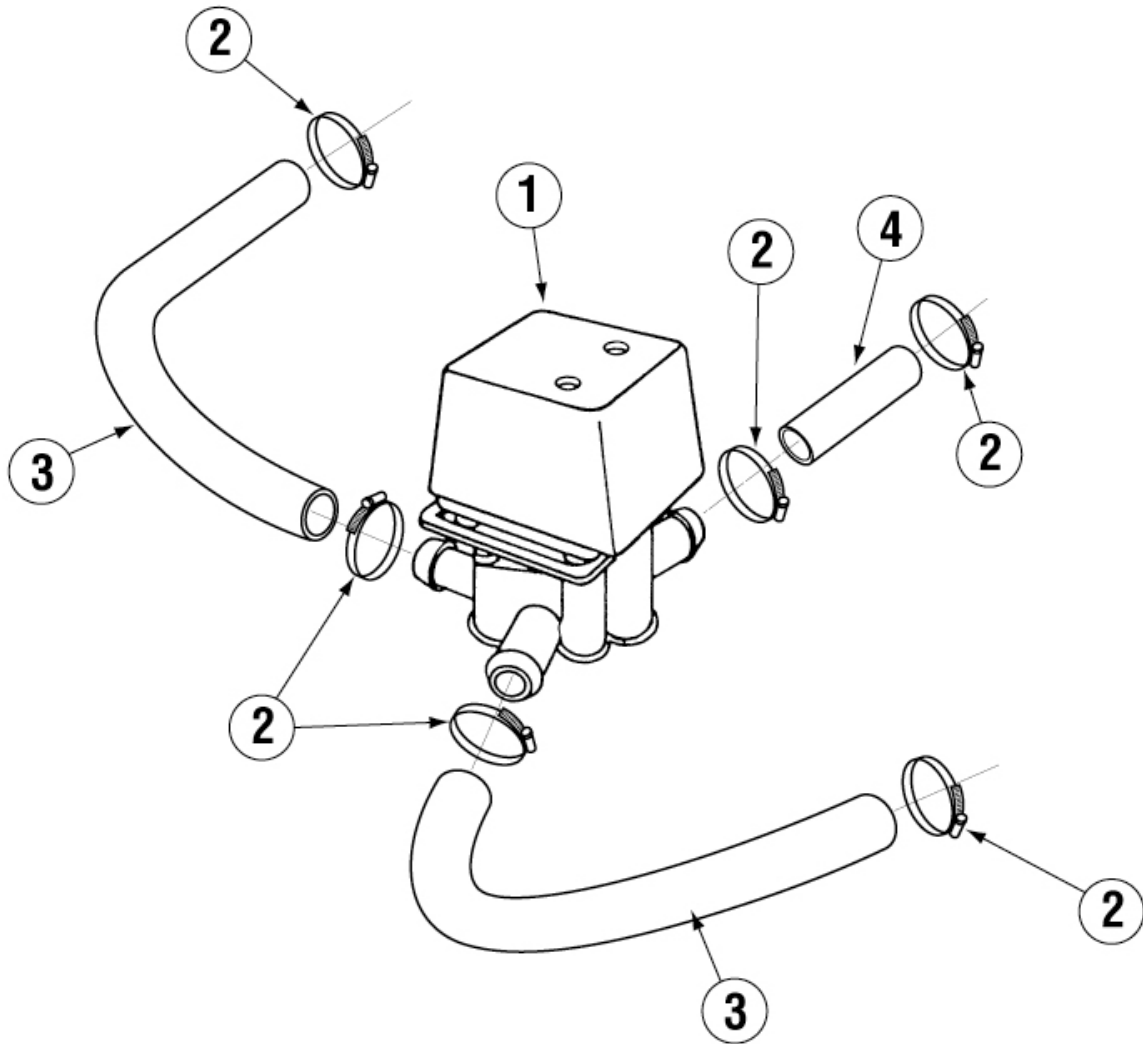

ITEM NO.	NO. REQ'D	P/N	DESCRIPTION
1	1	04113.00	Drain Valve 120V
2	6	03101.00	Hose Clamp #16-1"

ITEM NO.	NO. REQ'D	P/N	DESCRIPTION
3	2	15601.60	Hose 1" ID 14" Pump to Manifold
4	1	15601.10	Black Drain Hose 1" ID X 3 1/2"

1.4.5. Wash System

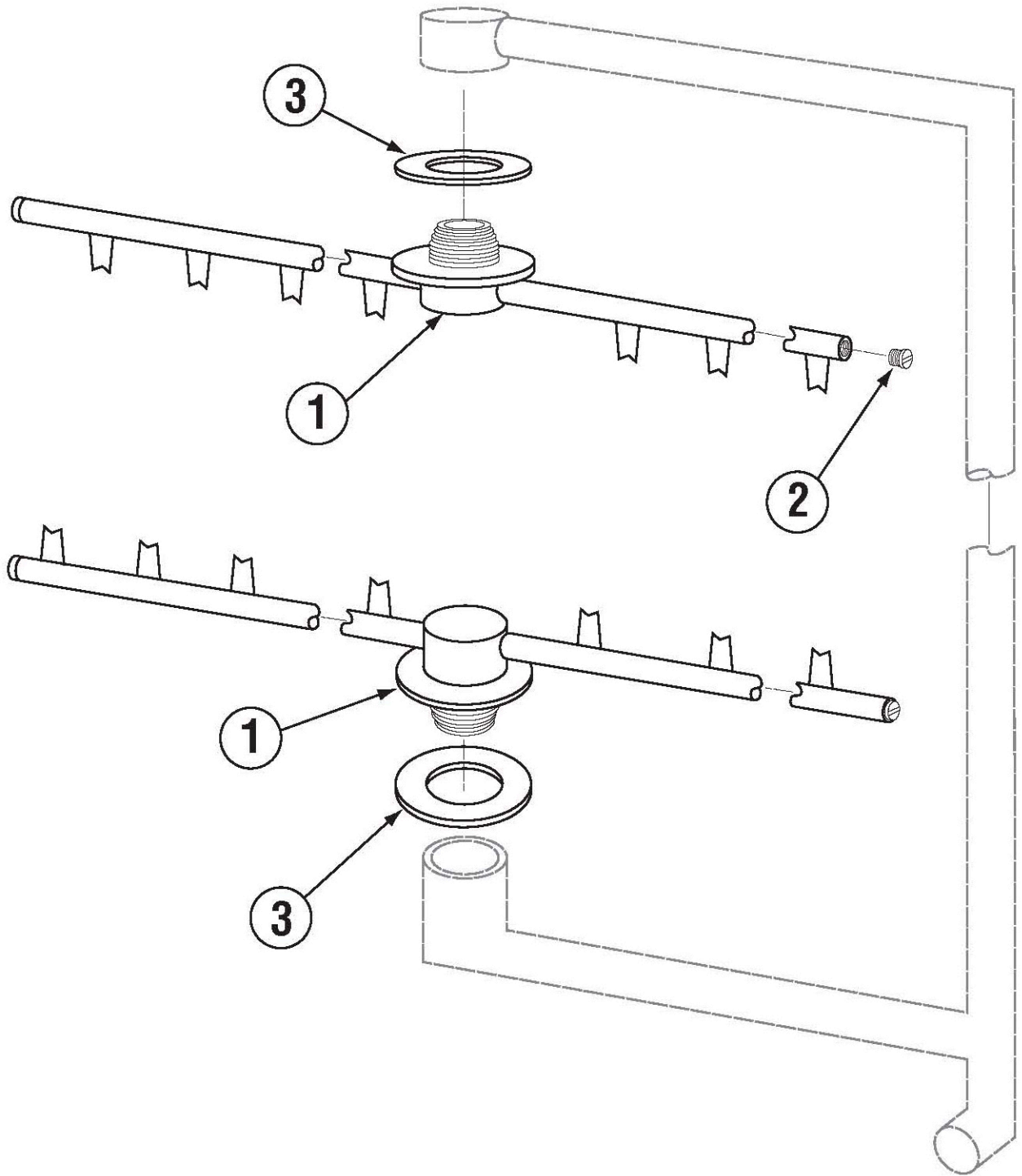

ITEM NO.	NO. REQ'D	P/N	DESCRIPTION
1	2	00304.46	Wash Arm
2	4	00308.20	Wash Arm End Plug

ITEM NO.	NO. REQ'D	P/N	DESCRIPTION
3	2	04305.17	Red Silicon Gasket 1/16" Thick

1.4.6. Rinse System

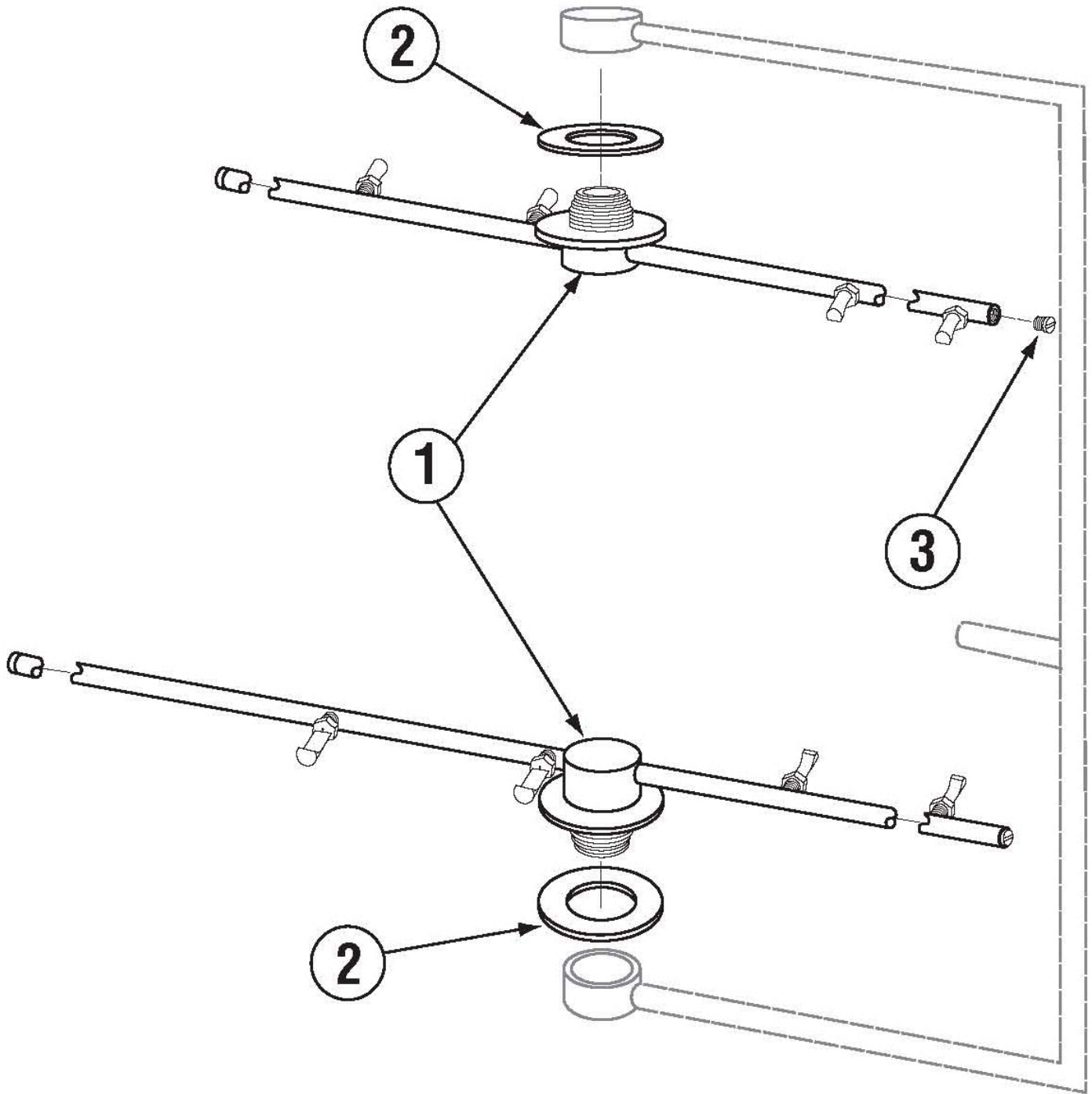

ITEM NO.	NO. REQ'D	P/N	DESCRIPTION
1	2	00304.29	Rinse Arm CMA-180UC
2	2	04305.17	Red Silicon Gasket 1/16" Thick

ITEM NO.	NO. REQ'D	P/N	DESCRIPTION
3	4	00308.17	Rinse Arm End Cap

1.4.7. S/S Pump Assembly (Effective August 2009)

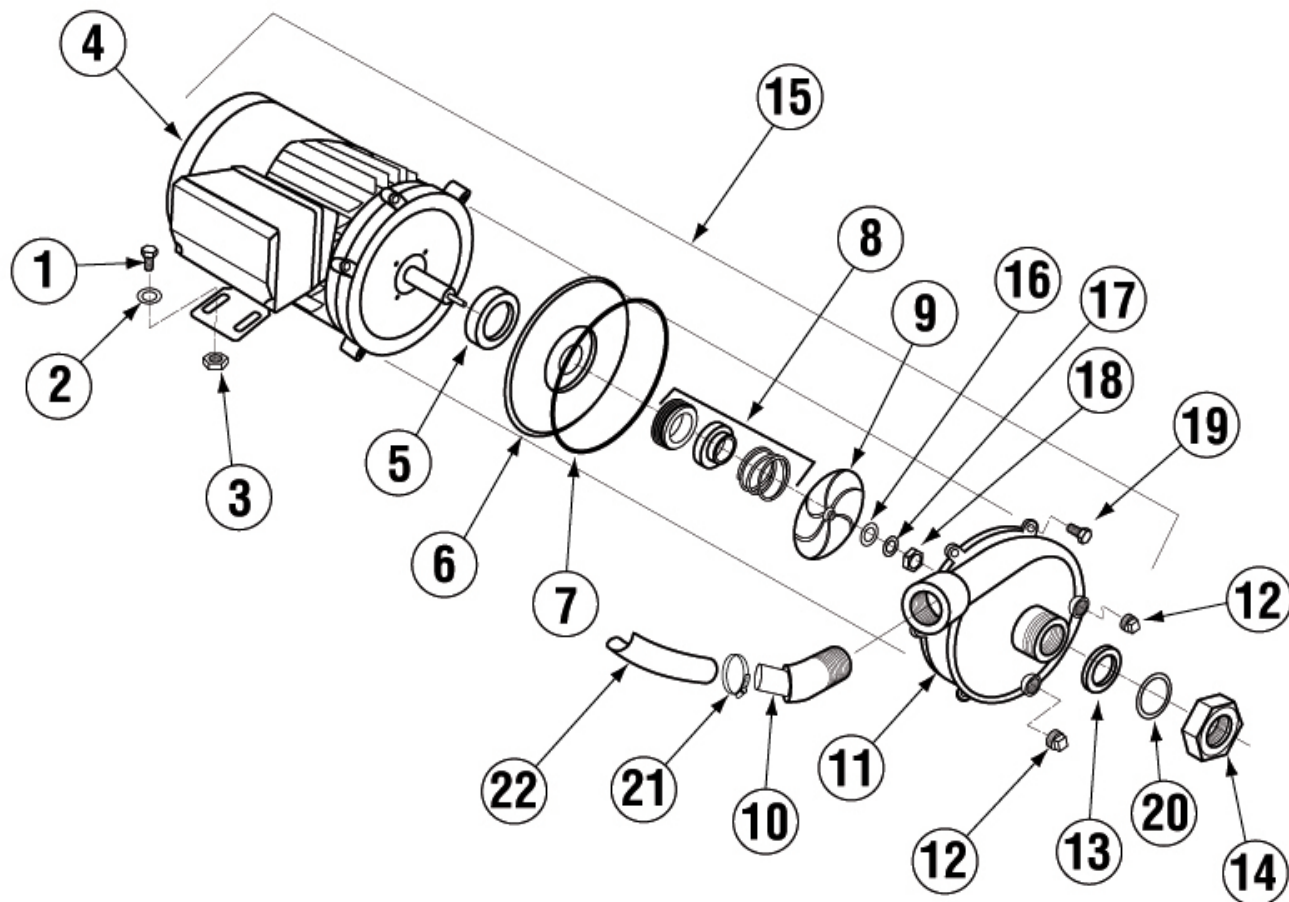

ITEM NO.	NO. REQ'D	P/N	DESCRIPTION
1	4	00908.00	5/16"-18 x 5/8" SS Hexhead Bolt
2	4	00926.00	5/16" SS Washer
3	4	00913.00	5/16"-18 Hex Nut
4	1	00201.60	SS Wash Pump Motor 220v
5	1	00201.96	Slinger Washer Cone Shape
6	1	03224.60	SS Pump Backplate
7	1	03226.70	Volute O-Ring For SS Pump
8	1	00206.70	SS Pump Seal Kit
9	1	03222.70	SS Pump Impeller
10	1	04604.00	^35 Deg Elbow MIP X Barb
11	1	04206.75	SS Pump Cover

ITEM NO.	NO. REQ'D	P/N	DESCRIPTION
12	2	00238.00	3/8" Male Plug
13	1	00208.40	Slip Joint Nut O Ring Buna
14	1	00207.00	Slip Joint Nut 1 1/2 x 1 1/4
15	1	00200.70	Includes Items 4,5,6,7,8,9,and 11
16	1	03222.74	Flat Washer 8 mm
17	1	03222.72	Shaft Nut Lock Washer 8mm
18	1	13809.70	SS Pump Seal Shaft Nut 8mm
19	6	00914.70	Socket Head Screw 10 mm
20	1	00208.21	Slip Joint Nut Friction Ring
21	1	03101.00	Hose Clamp # 16 1"
22	1	03108.61	Transfer Hose 1" Reinforce 23"

1.4.8. Pump System Assembly

CMA-180UC PUMP SYSTEM ASSEMBLY

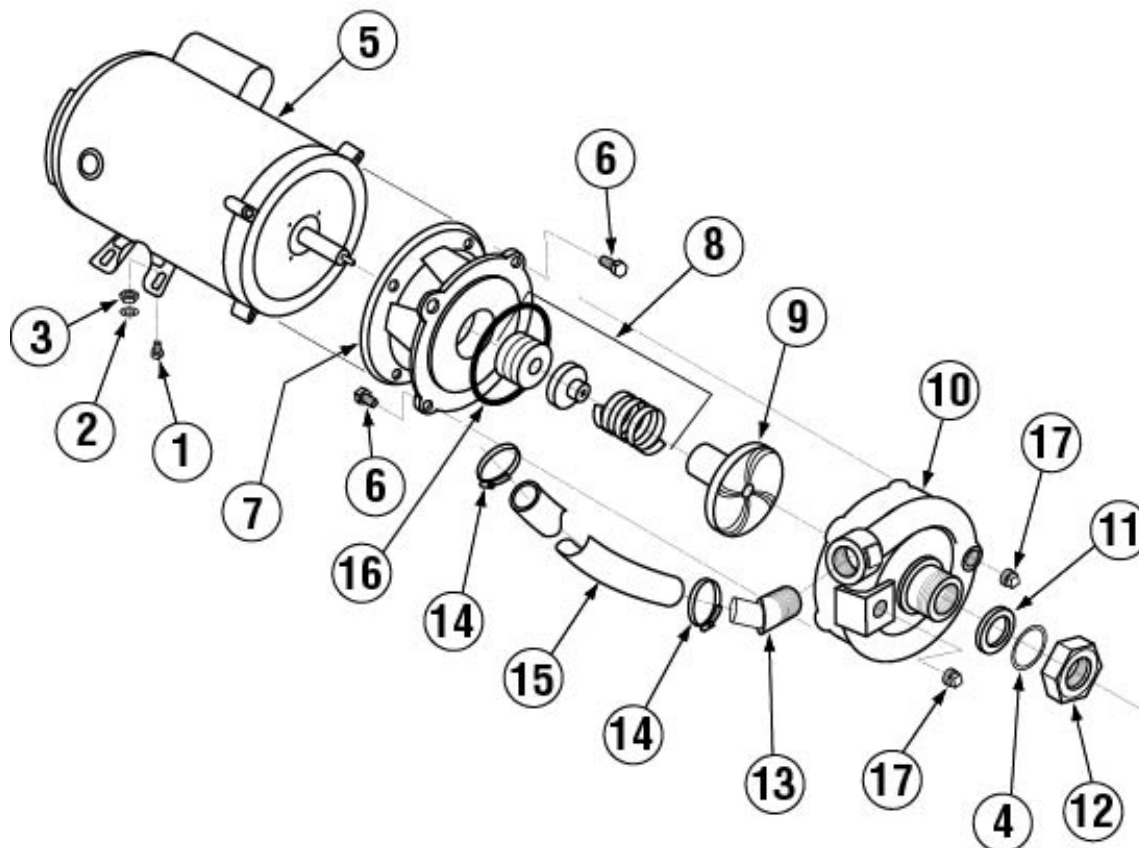

ITEM NO.	NO. REQ'D	P/N	DESCRIPTION
1	4	00908.00	5/16"-18 SS Hexhead Bolt
2	4	00926.00	5/16" SS Washer
3	4	00913.00	5/16"-18 Hex Nut
4	1	00208.21	Slip Joint Ring
5	1	00201.66	Water Pump Motor for CMA-180UC
6	8	00921.00	3/8"-16 x 3/4" Hex Bolt
7	1	04207.10	Pump Base (Mount)
8	1	00206.30	Pump Seal Kit
9	1	03222.10	Impeller L-1M

ITEM NO.	NO. REQ'D	P/N	DESCRIPTION
10	1	04207.20	Pump Cover
11	1	00208.40	Slip Joint Nut Gasket
12	1	04204.00	L-1X Compression Nut 2.5"
13	1	00213.50	Pump Fitting
14	2	03101.00	1" Hose Clamp #16
15	1	03108.62	Transfer Hose 1" Reinforce 25"
16	1	03226.00	Pump "O" Ring Gasket
17	2	00238.00	3/8" Male Plug

Pump assembly P/N 200.66 includes all the parts above, except ## 1,2,3,14,15.

1.4.9. Old Heater Assembly (Square Flange)

CMA-180UC HEATER ASSEMBLY

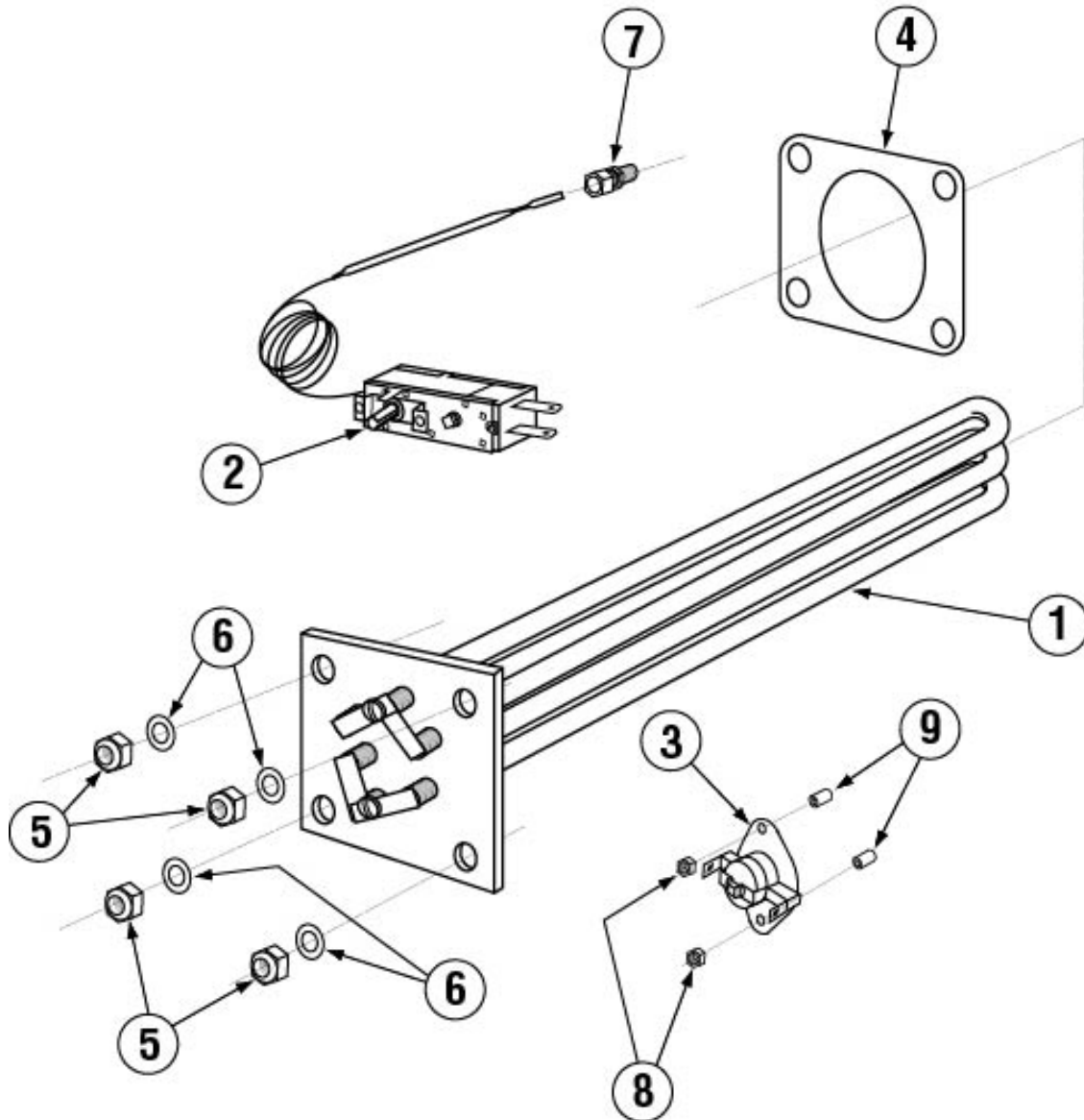

ITEM NO.	NO. REQ'D	P/N	DESCRIPTION
1	1	15517.00	Heater 6kW for CMA-180UC *
2	1	13417.89	Heater Thermostat
3	1	17523.60	High Limit Switch 200°F
4	1	15517.10	Heater Gasket
5	4	13805.00	5/16"-18 Nylon Insert Lock Nut

ITEM NO.	NO. REQ'D	P/N	DESCRIPTION
6	4	00926.00	5/16" SS Washer
7	1	40116.00	1/4" Compression x 1/4" MIP FTG
8	2	00965.00	6-32 Lock Nut
9	2	17524.00	High Limit Switch Spacer

*Gasket included

1.4.10. New Heater Assembly (Triangular Flange) After January 2020

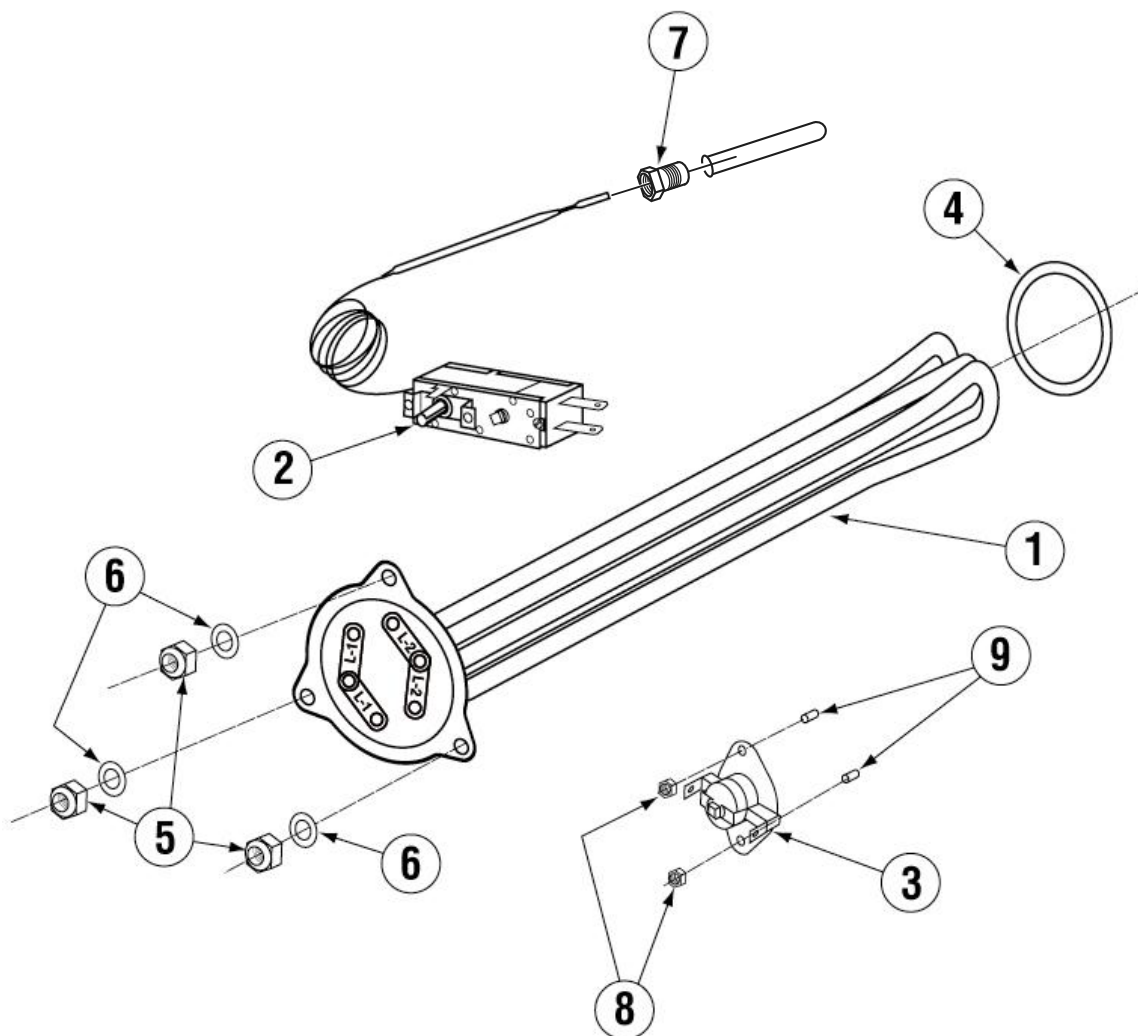

ITEM NO.	NO. REQ'D	P/N	DESCRIPTION
1	1	15518.00	Heater 6kW 220V Triangular Flange*
2	1	13417.89	Heater Thermostat
3	1	17523.60	High Limit Switch 200°F
4	1	15518.11	Gasket for Triangular Flange Heater
5	3	13805.00	5/16"-18 Nylon Insert Lock Nut

ITEM NO.	NO. REQ'D	P/N	DESCRIPTION
6	3	00926.00	5/16" SS Washer
7	1	13417.50	Thermowell Tube Assm
8	2	00965.00	6-32 Lock Nut
9	2	17524.00	High Limit Switch Spacer

* Gasket included

1.4.10. New Heater Assembly (Triangular Flange)

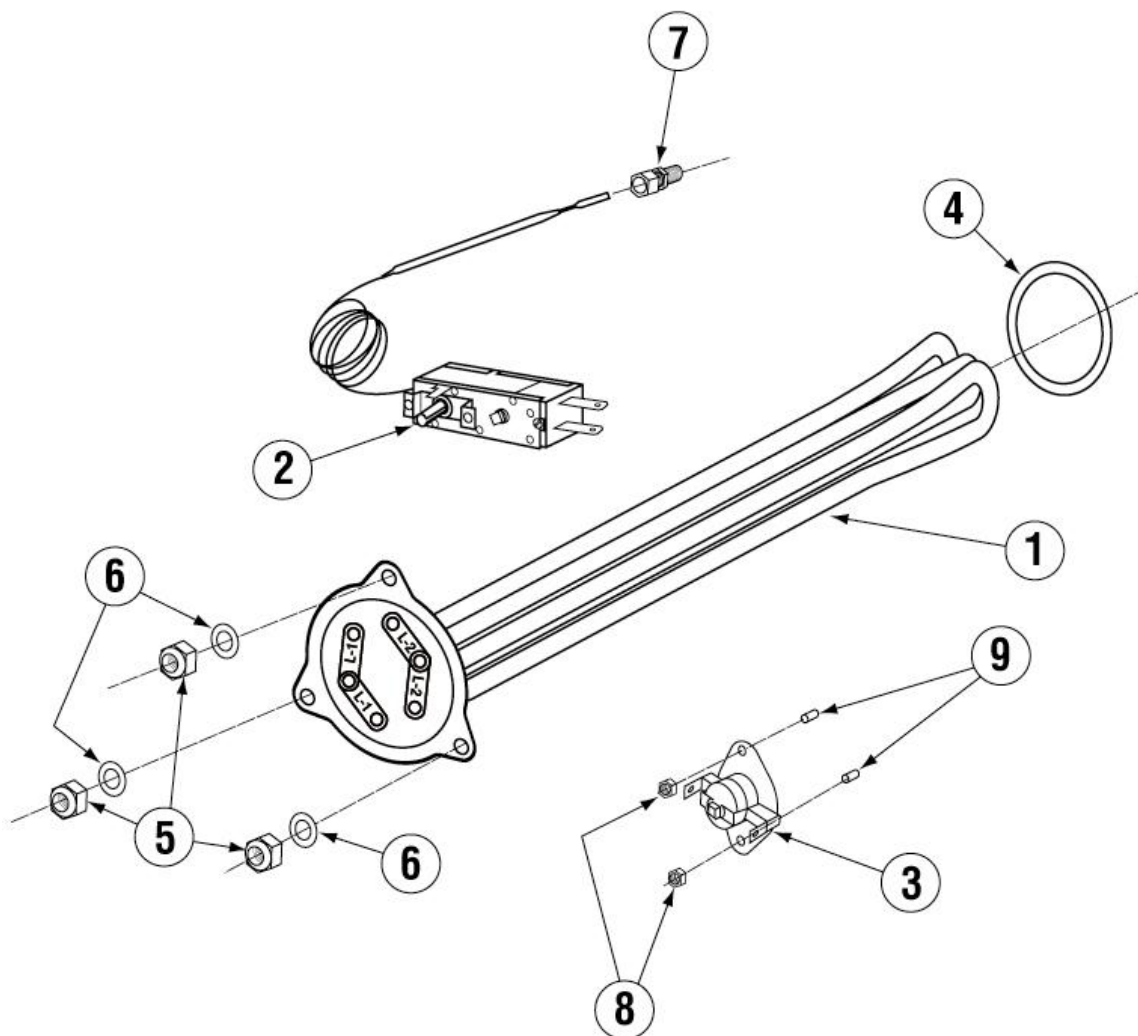

ITEM NO.	NO. REQ'D	P/N	DESCRIPTION
1	1	15518.00	Heater 6kW 220V Triangular Flange*
2	1	13417.89	Heater Thermostat
3	1	17523.60	High Limit Switch 200°F
4	1	15518.11	Gasket for Triangular Flange Heater
5	3	13805.00	5/16"-18 Nylon Insert Lock Nut

ITEM NO.	NO. REQ'D	P/N	DESCRIPTION
6	3	00926.00	5/16" SS Washer
7	1	40116.00	1/4" Compression x 1/4" MIP FTG
8	2	00965.00	6-32 Lock Nut
9	2	17524.00	High Limit Switch Spacer

* Gasket included

1.4.11. Drain Valve

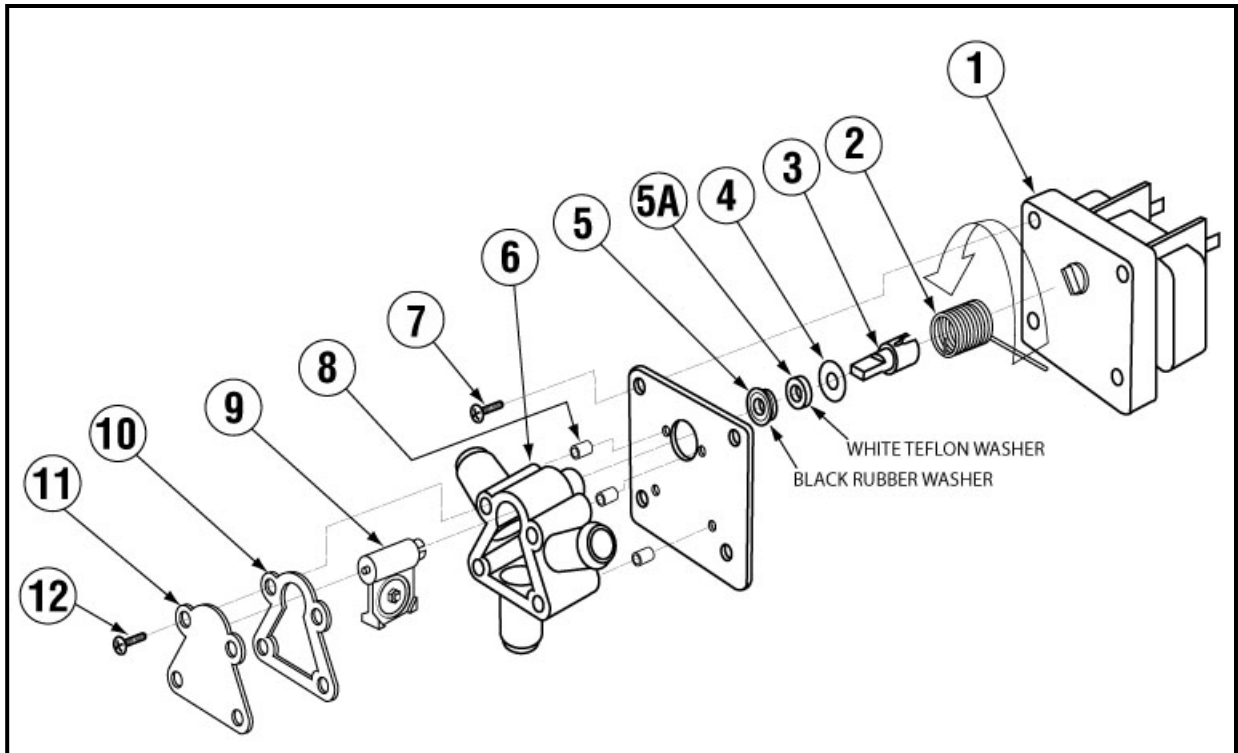

ITEM NO.	NO. REQ'D	P/N	DESCRIPTION
1	1	04103.21	Drain Motor 115V, 60Hz
2	1	04103.14	Drain Valve Spring
3	1	04103.20	Drain Valve Drive Pin
4	1	04103.19	Drain Valve Washer (Thin)
5	1	04103.17	Drain Seal Washer (Black)
5A	1	04103.23	Drain Seal Washer (White)
6	1	04103.12	Drain Valve Housing
7	4	00941.00	#10-32 x 5/8" Pan Head Screw
8	3	04103.24	Drain Valve Housing Spacer
9	1	04103.16	Hinge/Seal
10	1	04103.15	Drain Housing Gasket
11	1	04103.13	Drain Valve Housing Cover
12	4	04103.18	#8 x 5/8" Self-Threading Screw

1.4.12. Drain Valve (Effective January 2011)

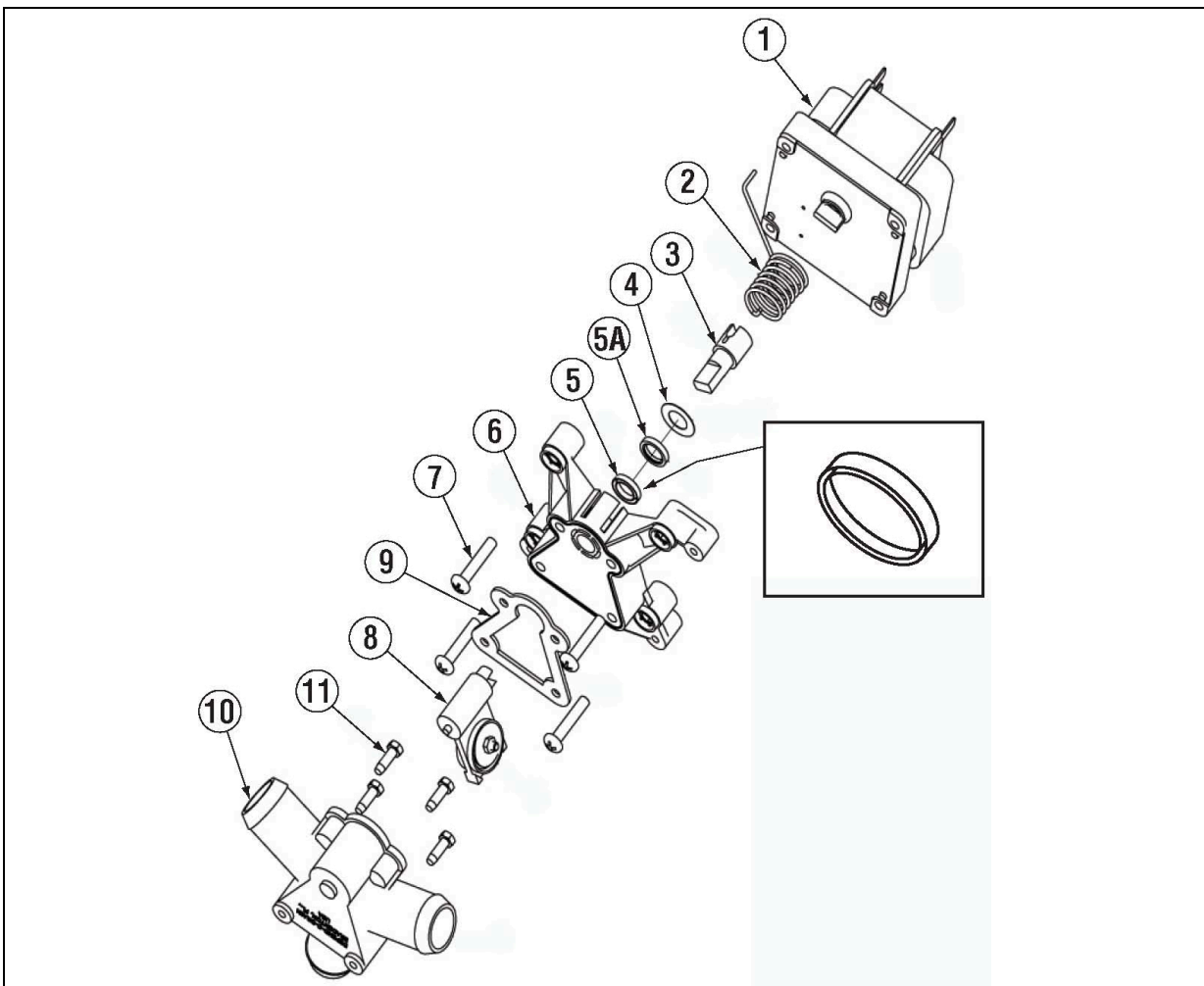

ITEM NO.	NO. REQ'D	P/N	DESCRIPTION
1	1	00104.50	Drain Motor 120V
2	1	04103.14	Drain Valve Spring
3	1	04103.20	Drain Valve Drive Pin
4	1	04103.19	Drain Valve Washer (Thin) SS
5	1	04103.17	Drain Valve Seal Washer (Rubber)
5A	1	04103.23	Drain Seal Bearing (White Washer)
6	1	04113.33	Drain Valve Housing Cover
7	4	04113.18	Valve Cover Screw
8	1	04113.16	Drain Valve Hinge/Seal
9	1	04103.15	Drain Valve Housing Gasket
10	1	04113.12	Drain Valve Housing (Includes #11&12)
11	2	04113.21	Screw #6-32 X 0.625 Flanged Hex
12	2	04113.23	Screw - #6-32 X 1.5" Flanged Hex
13	1	04113.13	Valve Cover Assy. Rectangular

1.4.13. Water Tempering Kit (Optional)

180UC Water Tempering Valve Kit

P/N 13470.50

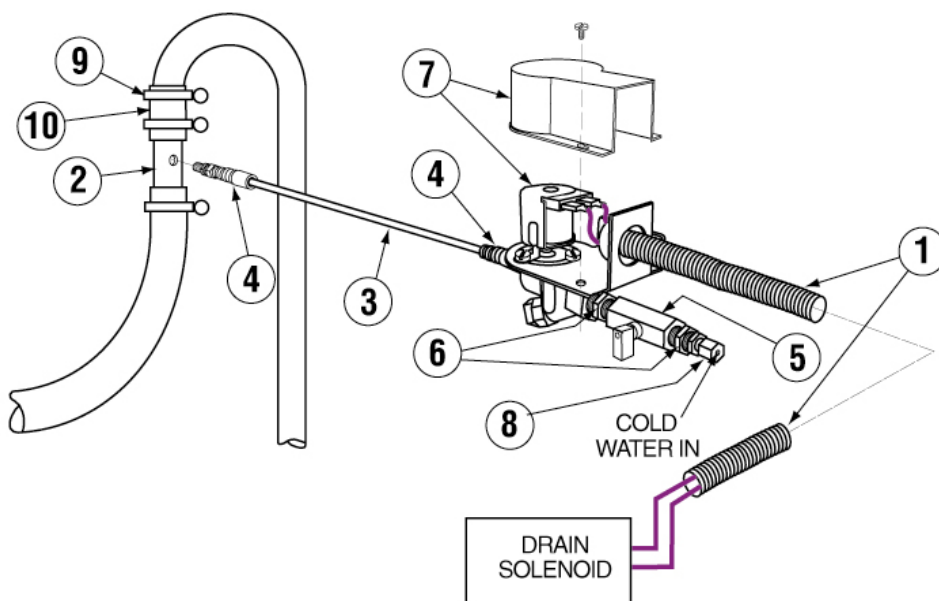

INSTALLATION INSTRUCTIONS TO DRAIN TEMPERING KIT

NOTE: Turn the dishwasher's wall breaker to "OFF" position before this installation.

1. Undo the drain hose clamp connecting the drain line gooseneck to drain hose leading to floor drain.
2. Install the water junction tee as shown on drain line gooseneck and tighten clamp.
3. Connect the drain hose to lower port of water injection tee and tighten hose clamp.
4. Insert the provided white chemical tube into compression nut of water injection tee and tighten compression nut.
5. Connect the provided cold-water solenoid's power leads to the drain solenoid.
6. Connect the water injection assembly's ball valve to a cold water supply.
7. Run the dishwasher through a few cycles and make sure the cold water is injected and check for any possible leaks.

ITEM NO.	P/N	NO REQ'D	DESCRIPTION
1.	15400.17	2.5	3/8" SLIT RIBBED TUBING
2.	15603.50	1	GOOSE NECK PIPE ADAPTER TEE
3.	00425.54	2	CHEMICAL TUBING WHITE
4.	03415.50	2	FLEX-TIGHT FITTING
5.	41014.49	1	3/8" BALL VALVE
6.	40015.00	2	3/8"X1/4" HEX BUSHING
7.	41015.00	1	SOLENOID VALVE 1/4" W/COVER 115V
8.	40116.00	1	1/4" COMP X 1/4" MIP FTG
9.	03101.00	2	HOSE CLAMP #16 1"
10.	03108.60	.25	TRANSFER HOSE 1" REINFORCED

Drain Water Tempering Valve Assembly (Effective 03-2023)

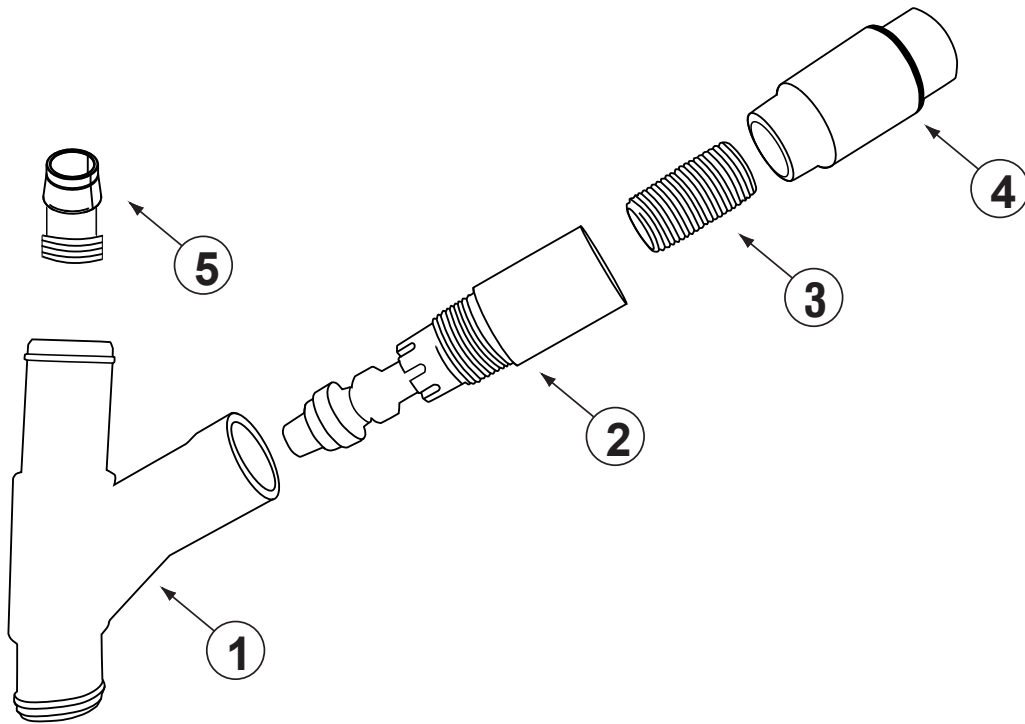

ITEM NO.	NO. REQ'D	P/N	DESCRIPTION
1	1	13470.86	DTV "Y" fitting
2	1	13470.85	Drain Water Tempering Valve
3	1	00742.00	Nipple Brass 1/2 x 1 1/2
4	1	00715.00	1/2 Ball Check Valve
5	1	00715.00	1/2 Ball Check Valve