



MODEL CMA-181VL

PARTS MANUAL

Rev 1.02 09-2021



CMA DISHMACHINES
12700 KNOTT STREET
GARDEN GROVE, CALIFORNIA 92841

800-854-6417

FAX 714-895-2141

wwwcmadishmachines.com

[Buy Parts](#)

TABLE OF CONTENTS

MODEL CMA-181VL

1. PARTS MANUAL	3
1.1. INITIAL PARTS KIT	3
1.2. MECHANICAL DRAWINGS.....	4
1.2.1. Cabinet Assembly.....	4
1.2.2. Heat Recovery System.....	5
1.2.3. Door Assembly.....	6
1.2.4. Electrical Tray P/N 18613.00.....	7
1.2.5. Control Box Assembly P/N 18613.50.....	8
1.2.6. Chemical Dispenser.....	9 & 10
1.2.7. Plumbing System Assembly.....	11
1.2.8. Drain System Assembly.....	12
1.2.9. Drain Pump	13
1.2.10. Wash System	14
1.2.11. Rinse System	15
1.2.12. Wash Pump Assembly.....	16
1.2.13. Rinse Pump Assembly.....	17
1.2.14. Heater Assembly.....	18
1.2.15. Drain Valve.....	19



1. Parts Manual

1.1. Initial Parts Kit

P/N	DESCRIPTION	Qty
15504.00	Motor Contactor, 2-Pole 20 Amp	1
15504.50	Heater Contactor, 2-Pole 35 Amp	1
00501.00	2-Minute Timer Motor	1
00631.00	Ice Cube Relay 120 V	1
41015.00	Solenoid Valve ¼" 120V	1
15523.00	Rocker Switch Start Momentary	1
00421.89	Rocker Switch Drain	1
15524.00	Rocker Switch Power Maintained	1
00556.10	Reed Switch	1
03623.00	1/2" Vacuum Breaker Repair Kit – Watts	1
04113.00	L1X/L1-C Drain Valve 120V	1
00206.70	Pump Seal Kit	1
13417.89	Heater Thermostat	1
17523.60	High Limit Switch 200°F	1
00411.00	Microswitch	1
03203.01	Dual Temperature Display Kit	1
00738.15	Solenoid Coil JE 115V/60Hz	1
00404.82	Motor Mini Contactor	1

1.2. Mechanical Drawings

1.2.1. Cabinet Assembly

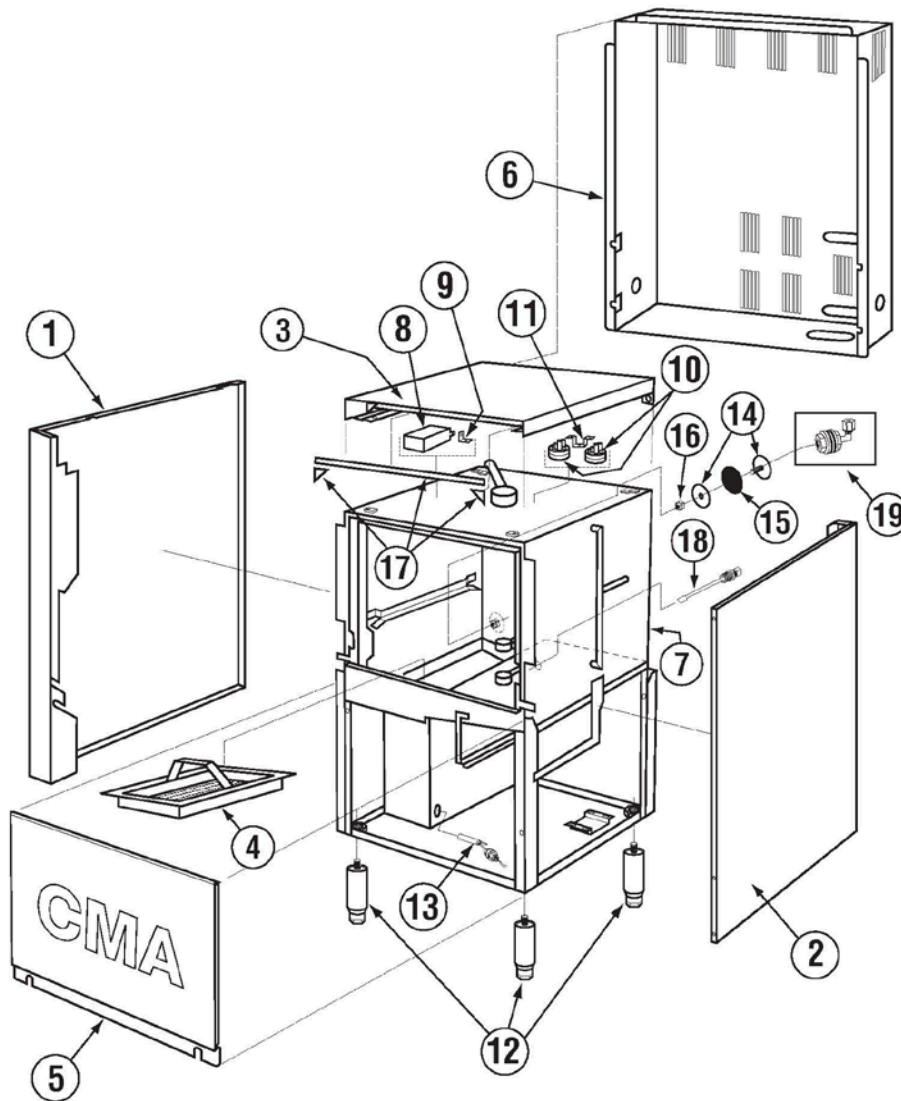

ITEM NO.	NO. REQ'D	P/N	DESCRIPTION
1	1	02816.00	CMA-181VL Left Side Cover
2	1	02815.00	CMA-181VL Right Side Cover
3	1	02806.00	CMA-181VL Top
4	1	14510.00	Scrap Basket for CMA-180UC
5	1	02817.00	CMA-181VL Front Panel
6	1	02835.00	CMA-181VL Rear Cover
7	1	02805.00	CMA-181VL Body
8	1	02828.00	CMA-181VL Slow Start Motor Relay
9	4	13001.26	CMA-44P Drain Support Bracket
10	2	02100.41	UC 50e Pressure Switch

ITEM NO.	NO. REQ'D	P/N	DESCRIPTION
11	1	02104.90	Pressure Switch Bracket
12	4	01146.00	^Leg 6" 1/2 -13 Thread
13	1	13463.10	Liquid Level Switch
14	1	01513.00	Detergent Injection Hole Plug
15	1	00752.00	Detergent Injection Hole Plug Gasket
16	1	00912.00	1/4"-20 Nylon Lock Nut
17	2ft	03705.84	Control Box Gasket for CMA-180UC
18	1	03204.50	Thermo well Ass'Y Cma-180UC (Wash)
19	1	03415.00	Chemical Bulk Head

1.2.2. Heat Recovery System

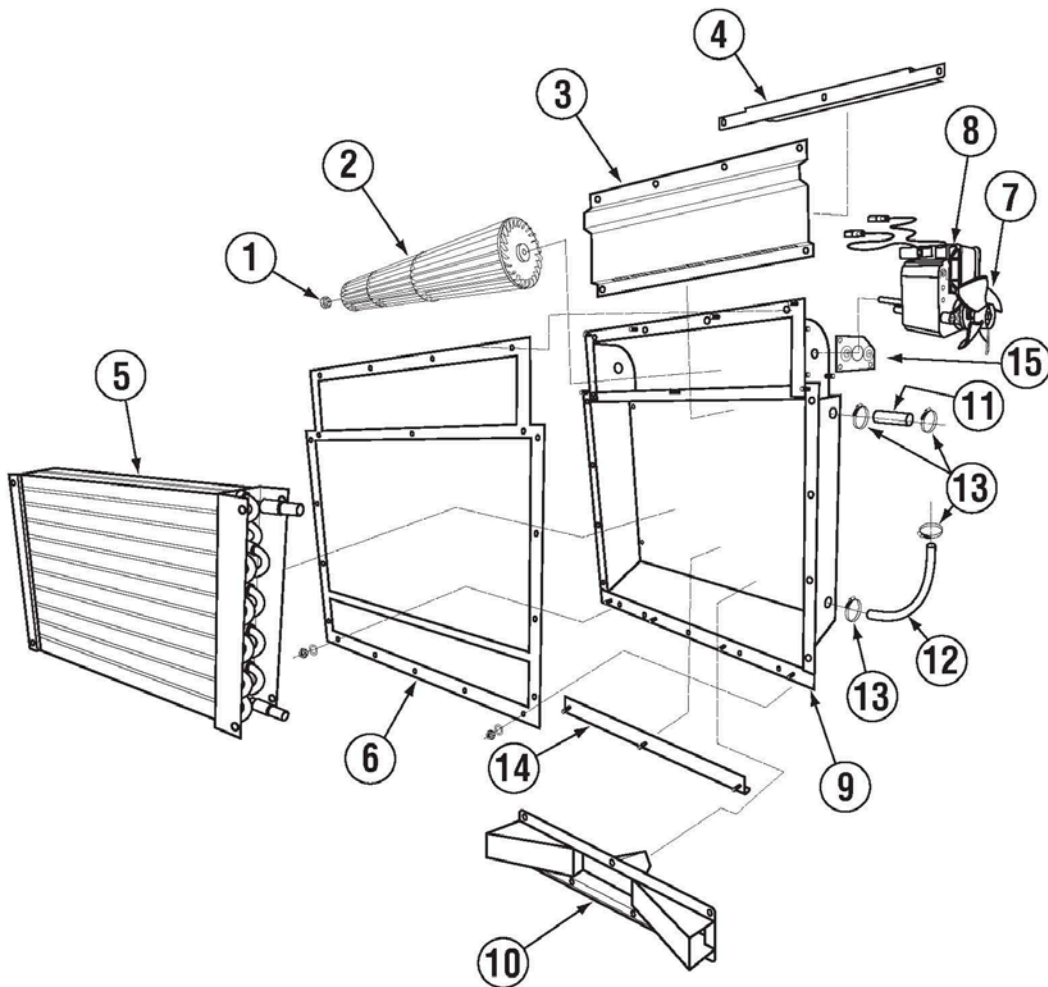

ITEM NO.	NO. REQ'D	P/N	DESCRIPTION
1	1	02801.20	Cross Flow Blower Bushing
2	1	02801.10	Cross Flow Blower
3	1	02808.00	CMA-181VL Intake Vent
4	1	02809.00	CMA-181VL Diverter Bracket
5	1	02401.08	CMA-181VL Condenser Coil
6	1	02840.00	CMA-181VL Back Inner Gasket
7	1	02801.40	Cross Flow Blower Fan
8	1	02801.30	Cross Flow Blower Motor

ITEM NO.	NO. REQ'D	P/N	DESCRIPTION
9	1	02810.00	CMA-181VL Fan Housing
10	1	02807.00	CMA-181VL Return Vent
11	1	03107.54	Flexible Hose 1/2" X 2 3/4"
12	1	03107.55	Flexible Hose 1/2" X 9 1/2"
13	4	03101.45	Hose Clamp #4
14	1	02819.00	CMA-181VL Back Brace
15	1	02811.00	Fan Motor Mount

1.2.3. Door Assembly

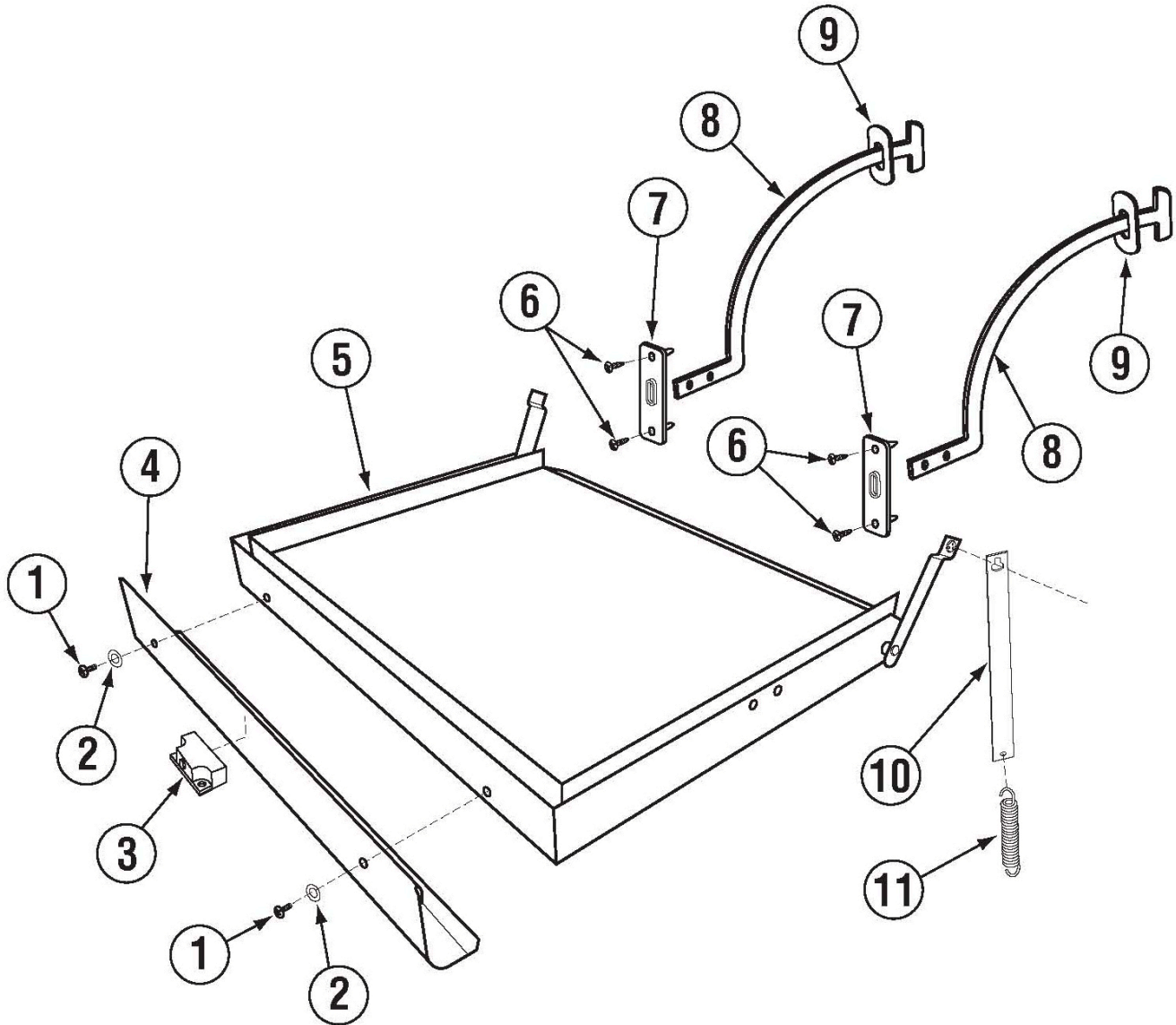

ITEM NO.	NO. REQ'D	P/N	DESCRIPTION
1	2	00940.50	10-32 x 3/8 Truss Head Screw
2	2		
3	1	00556.60	Reed Switch Magnet Only - ISI
4	1	02814.00	CMA-181VL Door Handle
5	1	02813.00	CMA-181VL Door
6	4	02100.79	Phillip Panhead Screw 6 x 3/8

ITEM NO.	NO. REQ'D	P/N	DESCRIPTION
7	2	02100.80	Door Rod Slide
8	2	02821.50	CMA-181VL/L-1C Door Rod
9	2	02823.00	CMA-181VL/L-1C Door Rod Washer
10	2	05913.00	L-1C Door Spring Arm
11	2	05932.00	Energy Miser L-1C Door Spring

1.2.4. Electrical Tray P/N 18613.00

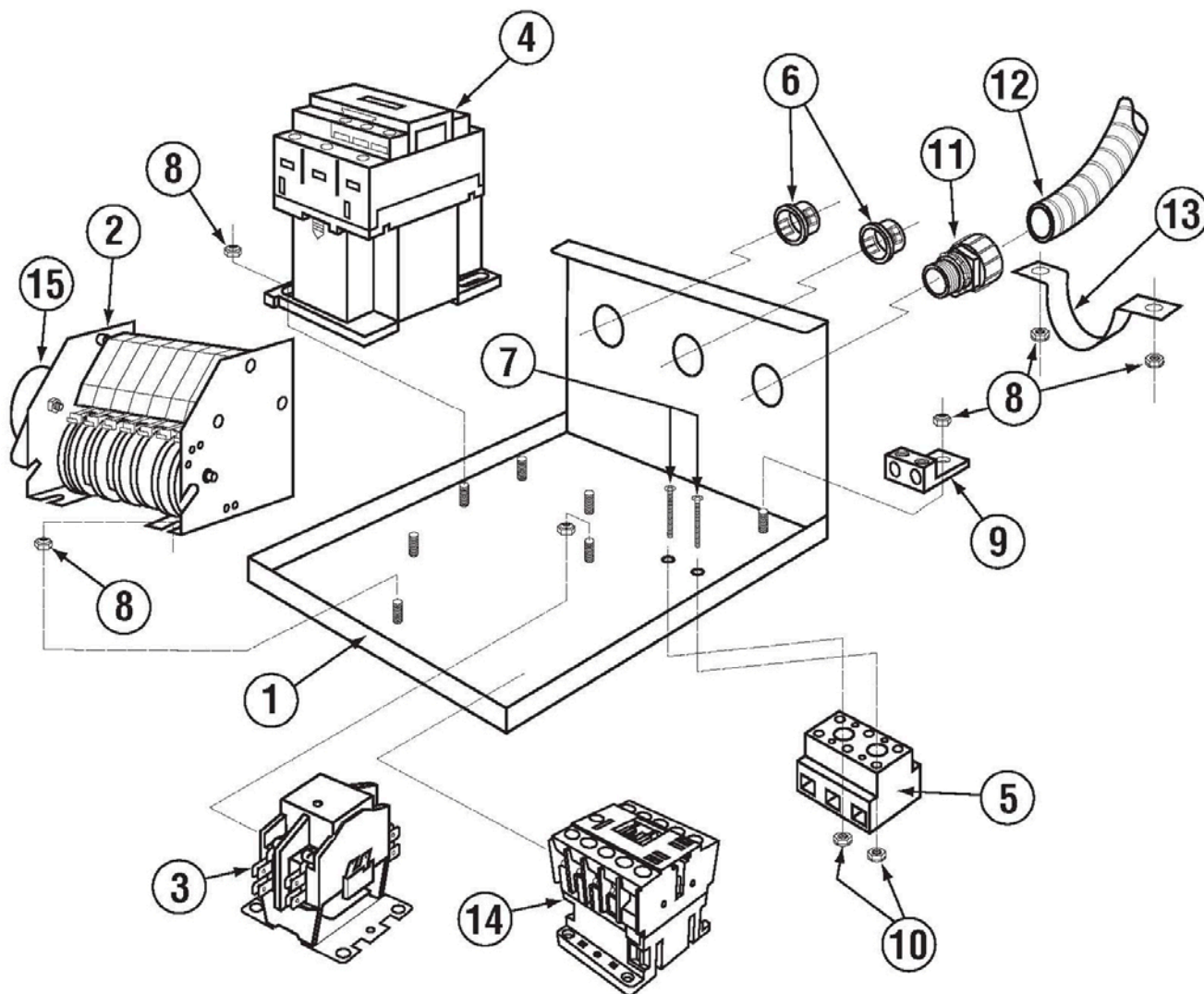

ITEM NO.	NO. REQ'D	P/N	DESCRIPTION
1	1	14504.00	Electrical Tray for CMA-180UC
2	1	14408.86	Timer Assy 3 Min for 181VL
3	1	15504.00	Motor Contactor, 2-Pole 20 Amp
4	1	15504.50	Heater Contactor, 2-Pole 35 Amp
5	1	15520.50	Power Block, 3-Position
6	2	00438.00	Snap Bushing, Universal
7	2	01001.00	6-32 x 1" Panhead Screw

ITEM NO.	NO. REQ'D	P/N	DESCRIPTION
8	12	00927.00	8-32 Nylon Lock Nut
9	1	13426.60	Ground Block
10	2	00965.00	6-32 Lock Nut
11	1	00401.85	3/4" Conduit Connector, Straight
12	9	00400.85	3/4" Conduit, Sealtite
13	1	13304.61	HT Plumbing Bracket
14	1	13012.15	Contactor 5kW GLX 120V
15	1	00504.00	Timer Motor

1.2.5. Control Box Assembly P/N 18613.50

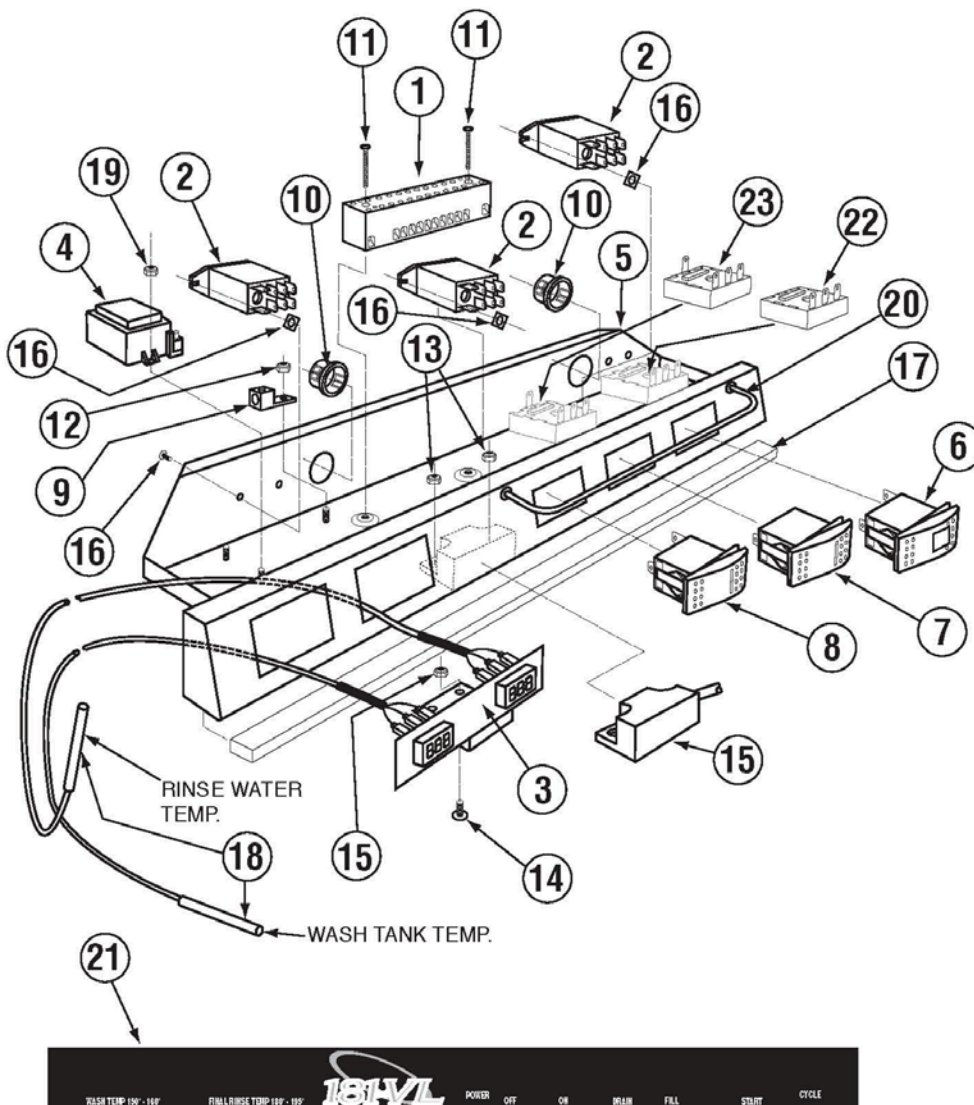

ITEM NO.	NO. REQ'D	P/N	DESCRIPTION
1	1	15520.00	Power Block 12-Position
2	3	00631.00	Ice Cube Relay 120 V
3	1	03203.01	Dual Temperature Display Kit
4	1	03202.60	Thermometer Transformer
5	1	02812.00	CMA-181VL Panel Facia
6	1	15523.00	Rocker Switch Start Momentary *
7	1	00421.89	Rocker Switch Drain Momentary *
8	1	15524.00	Rocker Switch Power Maintained *
9	1	13426.50	Ground Block
10	1	00438.00	Snap Bushing, Universal
11	2	01001.00	6-32 x 1" Panhead Screw
12	2	00965.00	6-32 SS Nylon Lock Nut

ITEM NO.	NO. REQ'D	P/N	DESCRIPTION
13	5	00927.00	8-32 Nylon Lock Nut
14	6	00911.00	8-32 x 1/2" Panhead Screw
15	1	00556.10	Reed Switch
16	4	00917.00	8-32 PM Nut
17	2	03705.82	Sponge Strip
18	2	03202.66	Thermocouple
19	2	00971.10	4-40 Nylon Lock Nut
20	1	03485.00	Switch Guard (Undercounter)
21	1	02825.00	CMA-181VL Panel Label
22*	1	00630.50	Timer Relay 120V
23*	1	00630.40	Extension Timer Relay 120V

* Effective January 2017

1.2.6. Chemical Dispenser Assembly January 2021

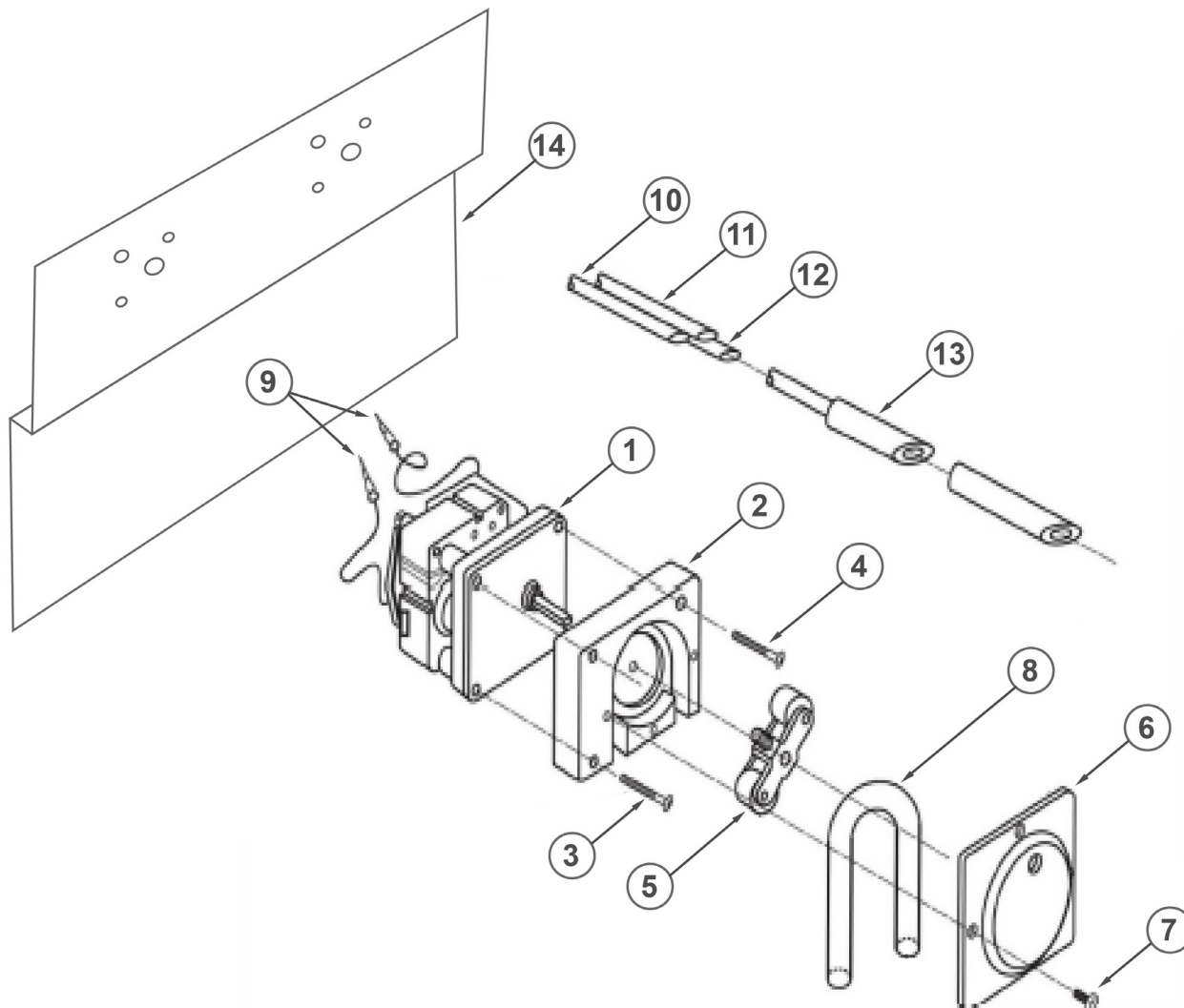

ITEM NO.	NO. REQ'D	P/N	DESCRIPTION
1	1	00416.00	Peristaltic Pump Motor
2	1	00417.10	Peristaltic Pump Block
3	1	00919.00	10-32x1-1/2" Pan Head Screw
4	1	00918.00	10-32x1-1/2" Fillister Head Screw
5	1	00419.00	Peristaltic Pump Rotor
6	1	00418.00	Peristaltic Pump Cover
7	1	00911.00	8-32x1/2" Pan Head Screw

ITEM NO.	NO. REQ'D	P/N	DESCRIPTION
8	1	02257.23	Squeeze Tube 11"
9	1	00448.00	Barrel Connector, Male
10	1	00425.23	Chemical Tubing, Red, 50 Ft Roll
11	1	00425.21	Chemical Tubing, Blue, 50 Ft Roll
12	1	00425.24	Chemical Tubing, White, 50 Ft Roll
13	1	00443.00	Tube Stiffener
14	1	14508.40	180UC Peri Pump Mount

1.2.6. Chemical Dispenser

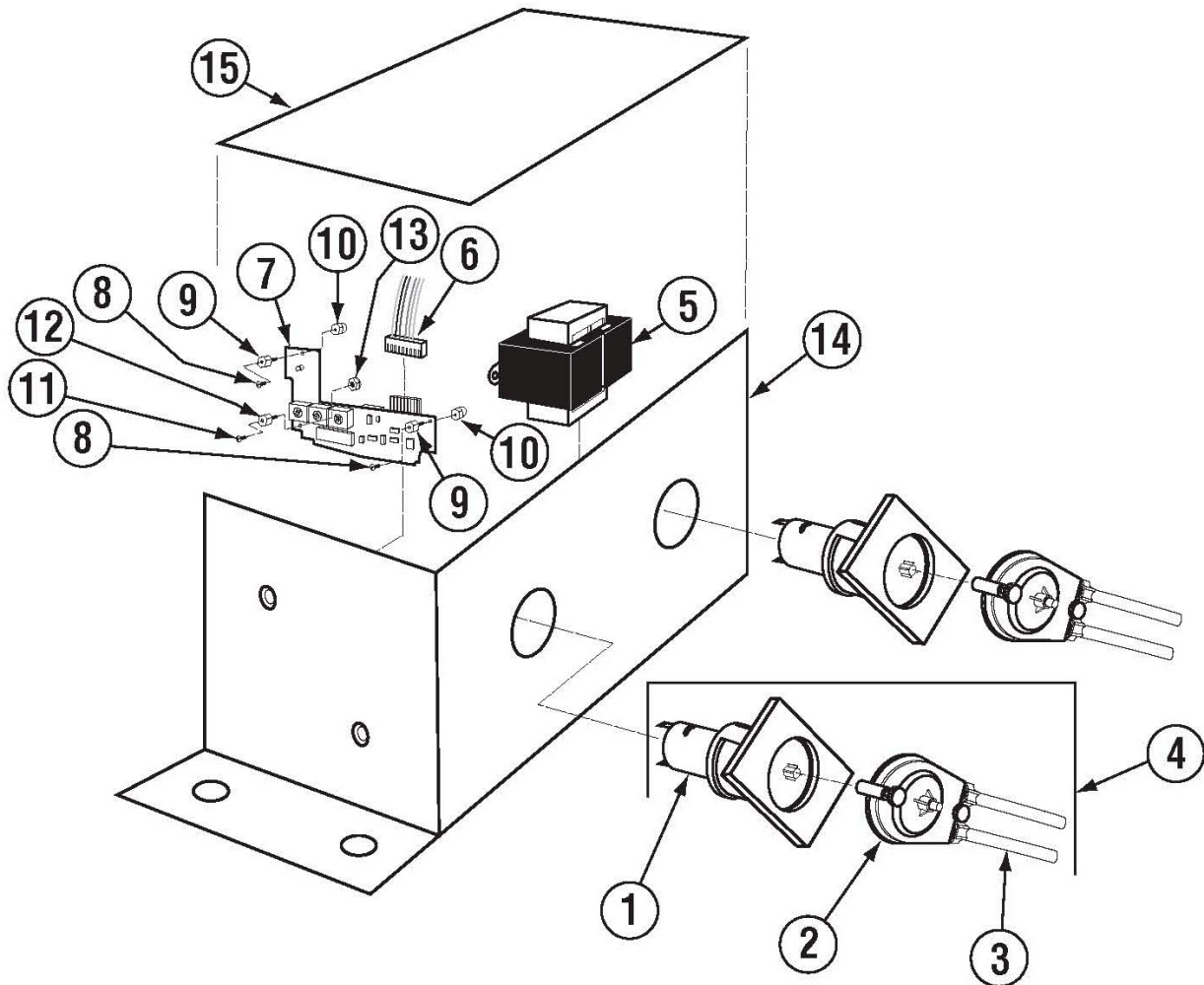

ITEM NO.	NO. REQ'D	P/N	DESCRIPTION
1	2	00816.00	Peri Pump Gear Motor (GL-C/GW-100)
2	2	00818.00	GL-C/GW-100 Peri Pump Cartridge
3	2	00839.00	GL-C/GW-100/UC180 Sqz Tube Clear
	2	00835.30	GL-C/GW-100/UC180 Sqz Tube Black
4	2	00815.00	GL-C Peri Pump Complete
5	1	00821.10	GL-C/GW-100 Transformer
6	2	00820.40	Circuit Board Connector
7	2	00820.00	GL-C/GW-100 Peri Pump Circuit Board

ITEM NO.	NO. REQ'D	P/N	DESCRIPTION
8	4	13826.47	4-40 x 3/16 Phil Pan Head Screw
9	4	00820.06	Circuit Board Standoff
10	4	00820.07	Circuit Board Standoff Cap
11	2	13826.00	4-40 X 5/8 Pan Head Screw
12	2	00820.50	Circuit Board Stand-off Bushing
13	2	00971.10	4-40 Nylon Lock Nut
14	1	14508.00	UC180 Peri Pump Box
15	1	14585.73	Dispenser Splash Shield

*Effective May 2019

1.2.7. Plumbing System Assembly

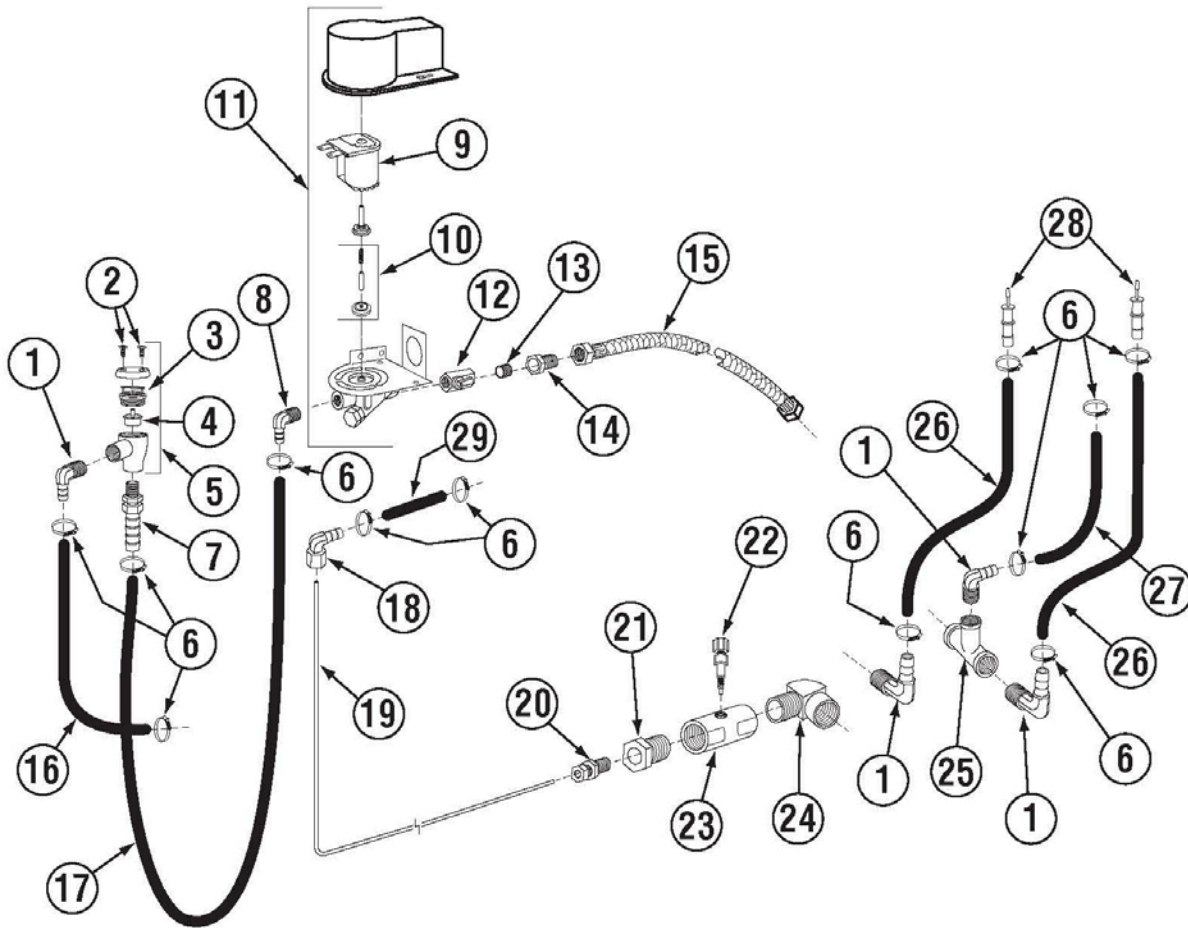

ITEM NO.	NO. REQ'D	P/N	DESCRIPTION
1	4	40013.00	1/2 Barb x 1/2 MPT 90Deg Ell
2	2	00421.51	6-32 x 1/4" SS Panhead Screw
3	1	03624.25	1/2" Vacuum Breaker Bonnet
4	1	03623.00	1/2" Vacuum Breaker Repair Kit
5	1	03624.00	1/2" Vacuum Breaker, Watts**
6	12	03101.46	Hose Clamp Size #5
7	1	40014.00	1/2MPT x 1/2 Hose Barb Straight
8	1	02826.00	1/2" Barb X 1/4" MPT Elbow
9	1	41015.60	Water Solenoid Coil Only 115V (Dema)
10	1	03604.30	Dema Valve Rep Kit
11	1	41015.00	Solenoid Valve 1/4" w/Cover 115V
12	1	41014.47	1/4 M x F Mini Ball Valve
13	1	41011.00	Nipple Brass 1/4 Close
14	1	13604.10	1/2 x 1/8 Bushing Brass
15	1	00798.30	SS Braided Hose 48"

ITEM NO.	NO. REQ'D	P/N	DESCRIPTION
16	1	03107.55	Flexible Hose 1/2" X 11"
17	1	03107.56	Flexible Hose 1/2" X 65"
18	1	40112.00	1/4 Comp x 1/4 MIP Ell
19	1	05004.30	CMA-181VI Rinse Line SS 1/4" X 65"
20	1	40116.00	1/4 Comp x 1/4 MIP Fitting
21	1	13604.00	1/2 x 1/4 Bushing Brass
22	1	13658.00	Chemical Inlet Check Valve 1/4" X 1/8
23	1	13669.45	Mixing Chamber SS CMA 180UC
24	1	00745.00	1/2 90Deg Street Elbow
25	1	13630.00	Tee 1/2 F x F x F SS
26	2	03107.57	Flexible Hose 1/2" X 6"
27	1	03107.58	Flexible Hose 1/2" X 24"
28	2	02701.00	Pressure Switch Hose Adapter
29	1	03107.54	Flexible Hose 1/2" X 2 3/4"

1.2.8. Drain System Assembly

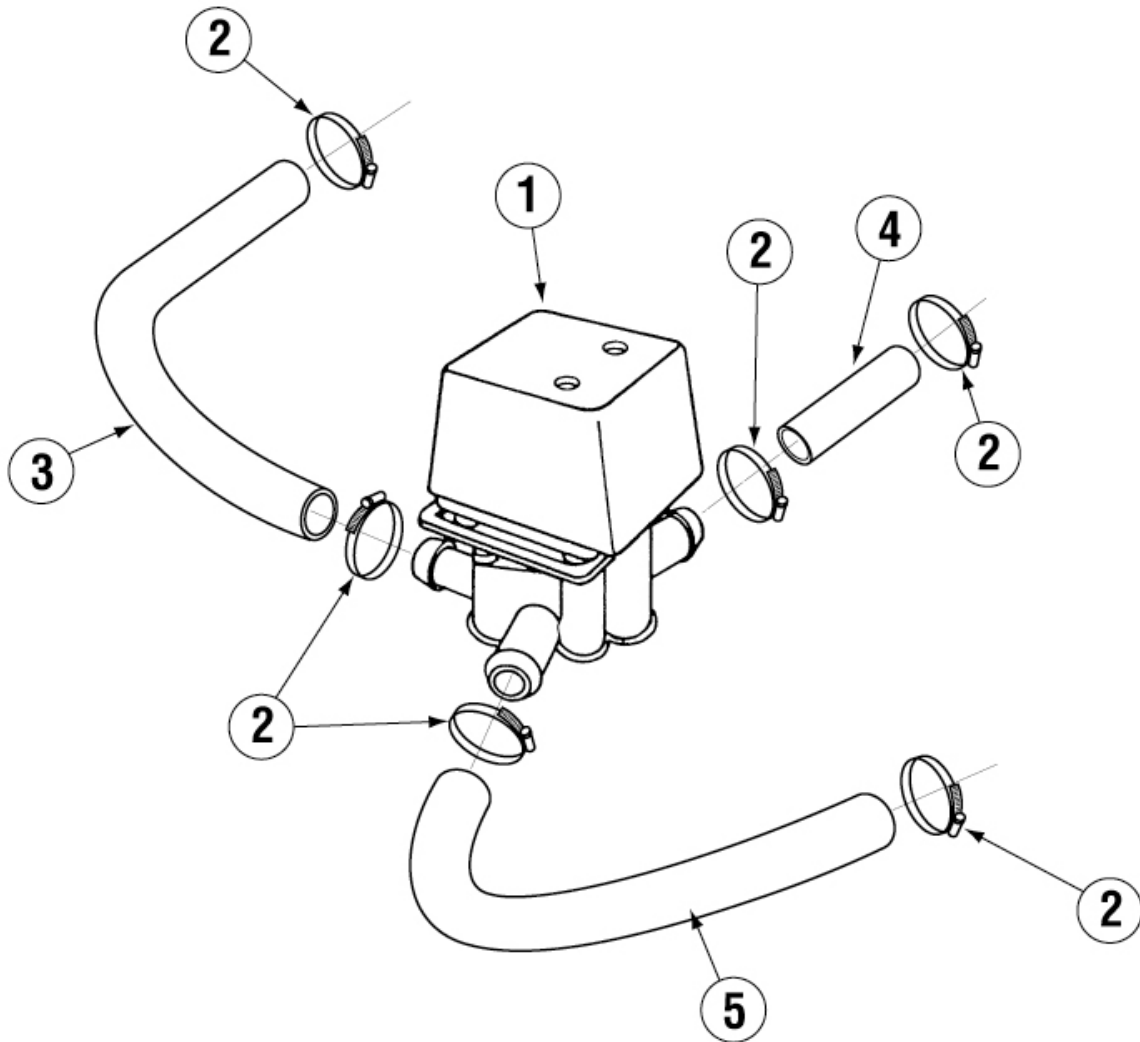

ITEM NO.	NO. REQ'D	P/N	DESCRIPTION
1	1	04113.00	Drain Valve 115V
2	6	03101.00	Hose Clamp #16-1"
3	1	03109.00	Transfer Hose 90Deg 1"

ITEM NO.	NO. REQ'D	P/N	DESCRIPTION
4	1	15601.00	Hose 1" ID 90Deg 3X11
5	1	N / A	Raw Material

1.2.9. Drain Pump

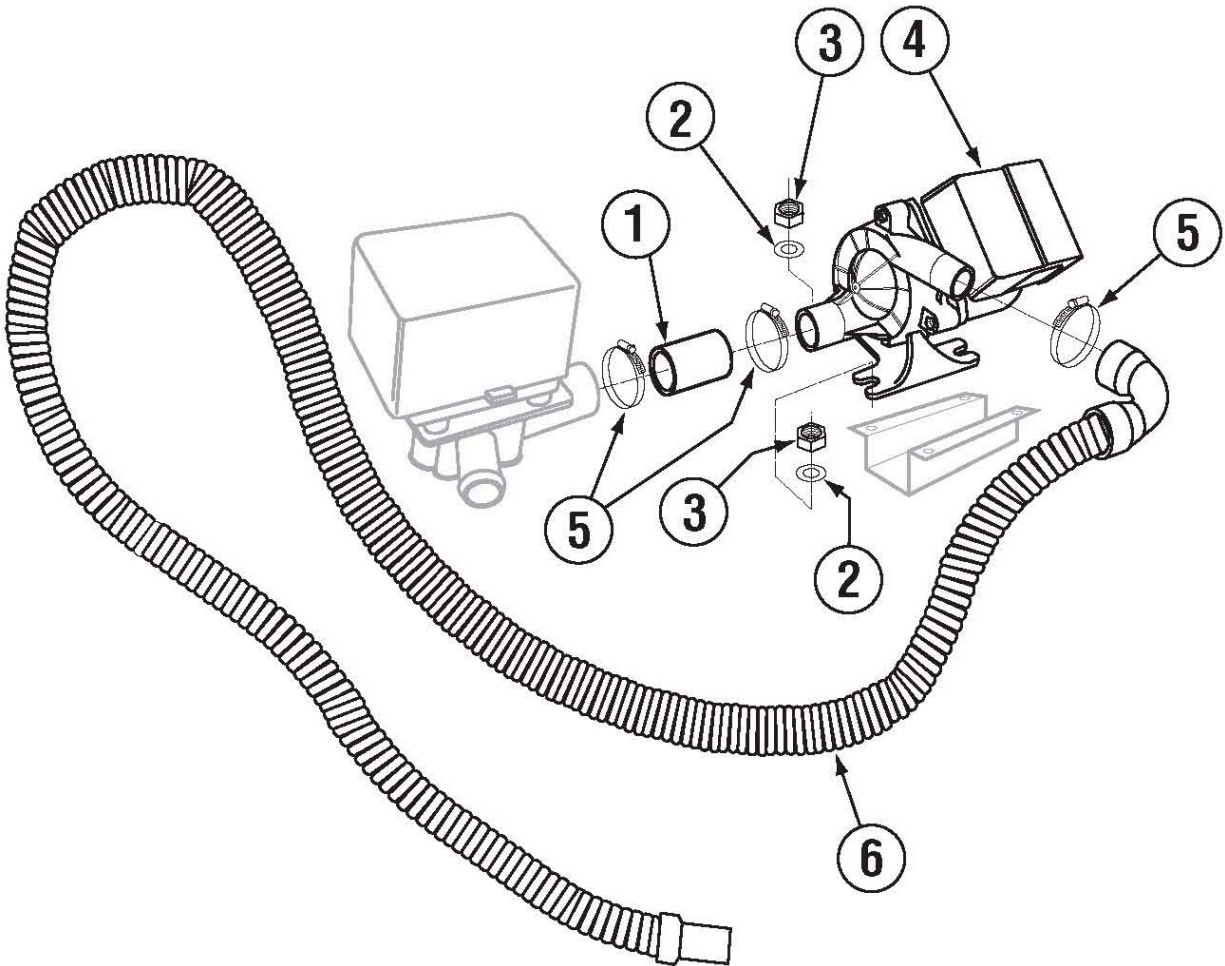

ITEM NO.	NO. REQ'D	P/N	DESCRIPTION
1	1	15601.10	Black Drain Hose 1" ID X 3 1/2"
2	4	04806.00	#10 Brass Washer
3	4	03801.10	10-32 SS Nut

ITEM NO.	NO. REQ'D	P/N	DESCRIPTION
4	1	15503.00	Drain Motor Ultra Jet for CMA-180UC
5	3	03101.00	Hose Clamp 1"
6	1	02104.84	UC-65 Drain Hose

1.2.10. Wash System

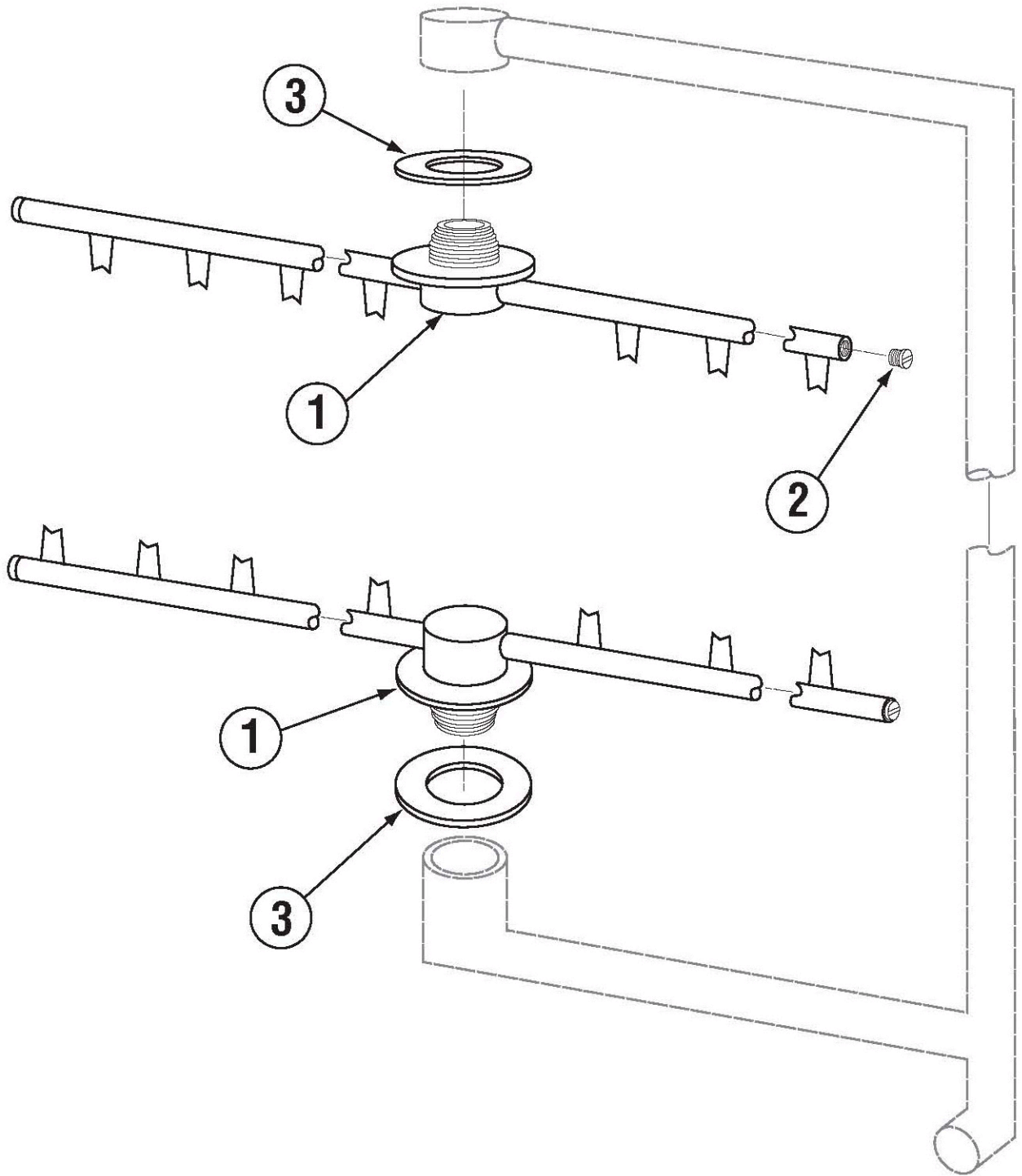

ITEM NO.	NO. REQ'D	P/N	DESCRIPTION
1	2	00304.39	Wash Arm 181VL
2	4	00308.20	Wash Arm End Plug

ITEM NO.	NO. REQ'D	P/N	DESCRIPTION
3	2	04305.17	Red Silicon Gasket 1/16" Thick

1.2.11. Rinse System

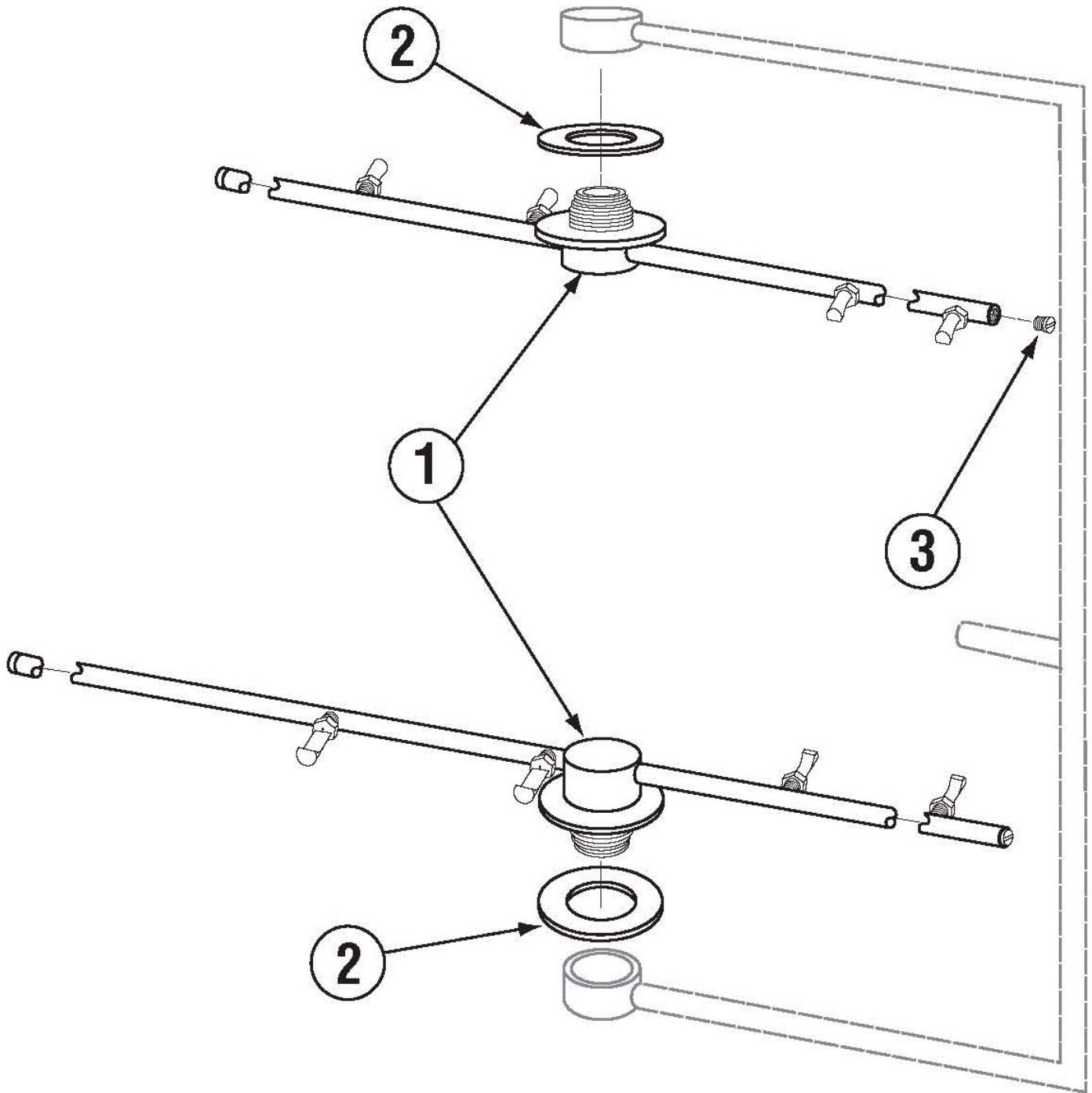

ITEM NO.	NO. REQ'D	P/N	DESCRIPTION
1	2	00304.49	Rinse Arm w/bearings 181VL
2	2	04305.17	Red Silicon Gasket 1/16" Thick

ITEM NO.	NO. REQ'D	P/N	DESCRIPTION
3	4	00308.17	Rinse Arm End Cap

1.2.12. Wash Pump Assembly

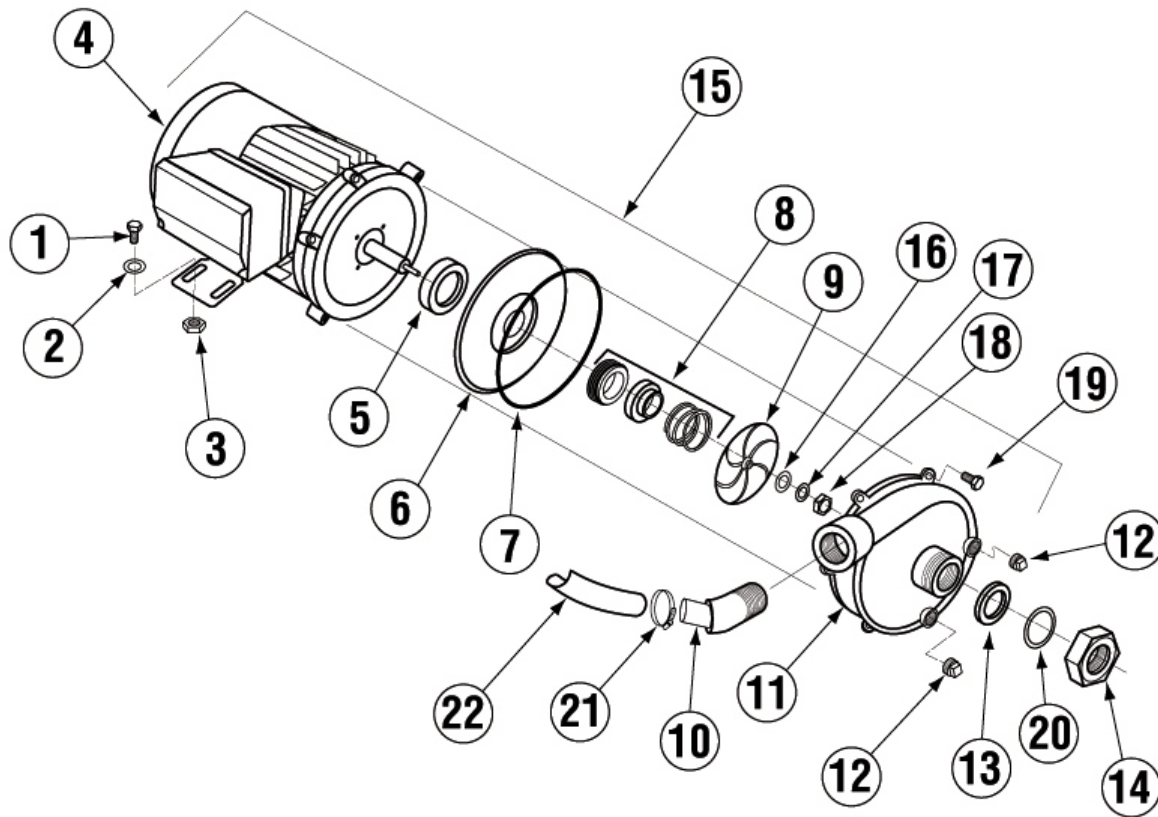

ITEM NO.	NO. REQ'D	P/N	DESCRIPTION
1	4	00908.00	5/16"-18 x 5/8" SS Hexhead Bolt
2	4	00926.00	5/16" SS Washer
3	4	00913.00	5/16"-18 Hex Nut
4	1	00201.60	SS Wash Pump Motor 220v
5	1	00201.96	Slinger Washer Cone Shape
6	1	03224.60	SS Pump Backplate
7	1	03226.70	Volute O-Ring For SS Pump
8	1	00206.70	SS Pump Seal Kit
9	1	03222.70	SS Pump Impeller
10	1	04604.00	^35 Deg Elbow MIP X Barb
11	1	04206.75	SS Pump Cover

ITEM NO.	NO. REQ'D	P/N	DESCRIPTION
12	2	00238.00	3/8" Male Plug
13	1	00208.40	Slip Joint Nut O Ring Buna
14	1	00207.00	Slip Joint Nut 1 1/2 x 1 1/4
15	1	00200.70	Includes Items 4,5,6,7,8,9,and 11
16	1	03222.74	Flat Washer 8 mm
17	1	03222.72	Shaft Nut Lock Washer 8mm
18	1	13809.70	SS Pump Seal Shaft Nut 8mm
19	6	00914.70	Socket Head Screw 10 mm
20	1	00208.21	Slip Joint Nut Friction Ring
21	1	03101.00	Hose Clamp # 16 1"
22	1	03108.62	Transfer Hose 1" Reinforce 25"

1.2.13. Rinse Pump Assembly

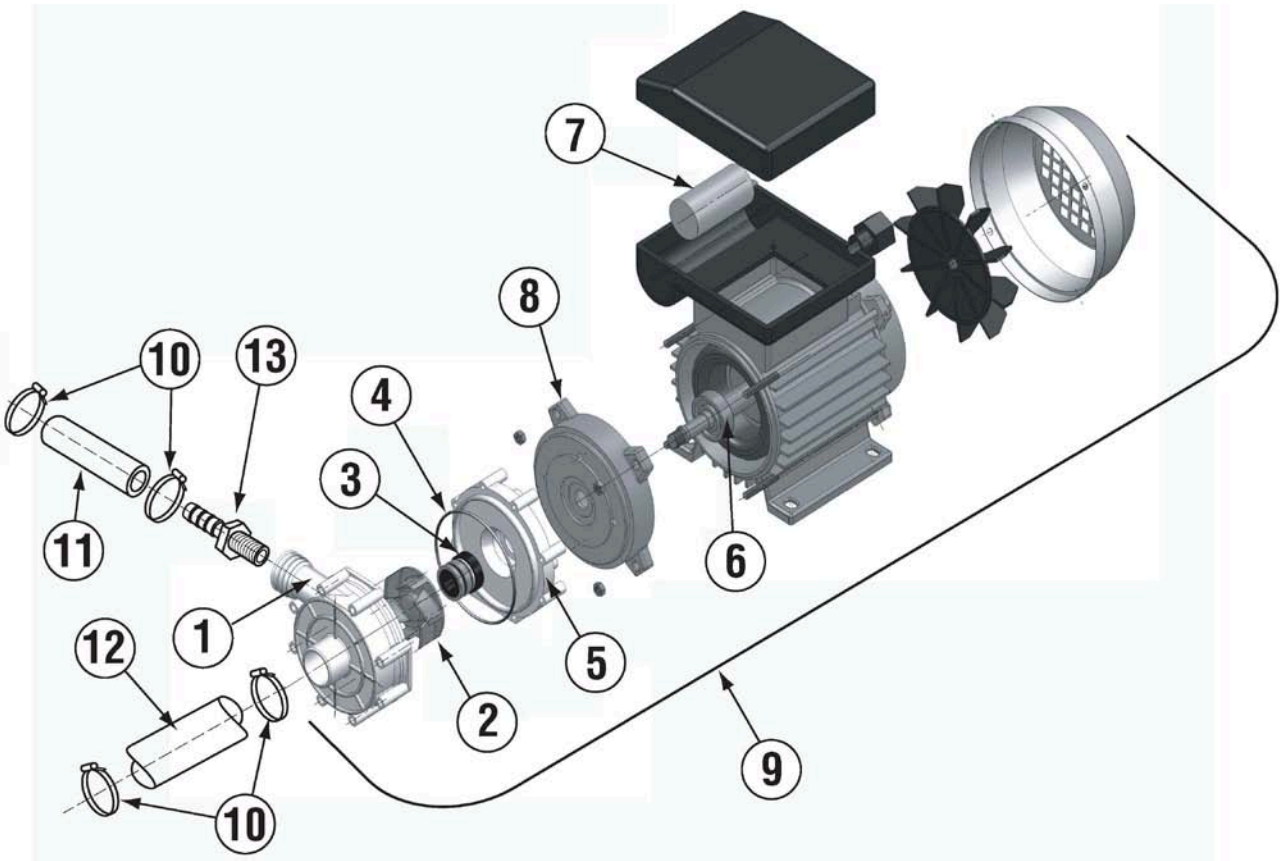

ITEM NO.	NO. REQ'D	P/N	DESCRIPTION
1	1	13503.82	Pump Head CMA181VL Threaded Outlet
2	1	13503.71	Impeller
3	1	13503.72	Seal Kit
4	1	13503.73	Pump O-Ring
5	1	13503.74	Back Plate
6	1	13503.75	Motor
7	1	13503.76	Capacitor

ITEM NO.	NO. REQ'D	P/N	DESCRIPTION
8	1	13503.77	Cover
9	1	13503.61	Rinse Pump CMA-181VL 1ph 208-240V
10	4	03101.00	Hose Clamp # 16 1"
11	ft	03107.54	1/2"x3-3/4"
12	ft	03107.53	1/2"x9-1/2"
13	1	40014.00	1/2MPT x 1/2 Hose Barb Straight

Parts Manual

1.4.10. New Heater Assembly (Triangular Flange) After January 2020

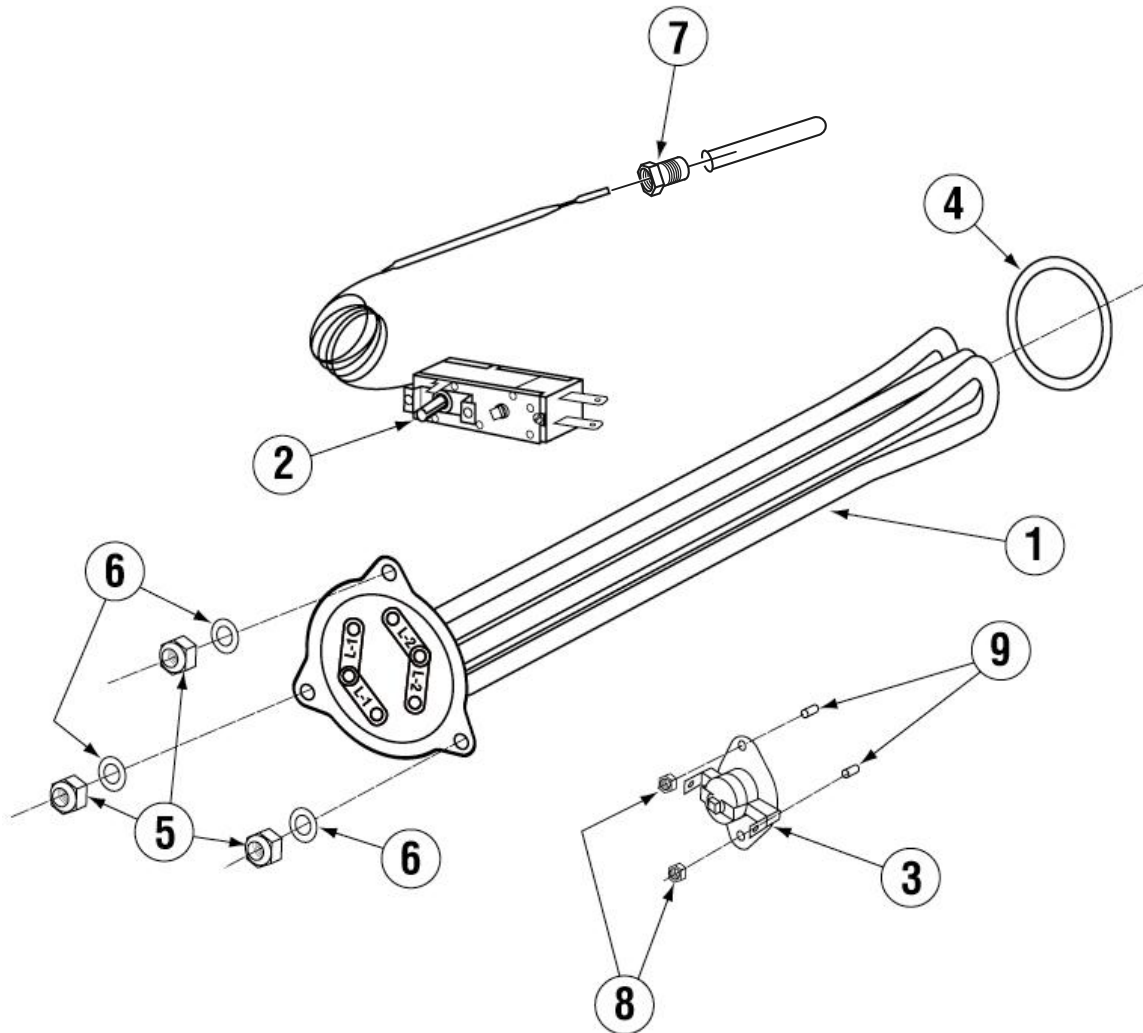

ITEM NO.	NO. REQ'D	P/N	DESCRIPTION
1	1	15518.00	Heater 6kW 220V Triangular Flange*
2	1	13417.89	Heater Thermostat
3	1	17523.60	High Limit Switch 200°F
4	1	15518.11	Gasket for Triangular Flange Heater
5	3	13805.00	5/16"-18 Nylon Insert Lock Nut

ITEM NO.	NO. REQ'D	P/N	DESCRIPTION
6	3	00926.00	5/16" SS Washer
7	1	13417.50	Thermowell Tube Assm
8	2	00965.00	6-32 Lock Nut
9	2	17524.00	High Limit Switch Spacer

* Gasket included

1.2.14. Heater Assembly

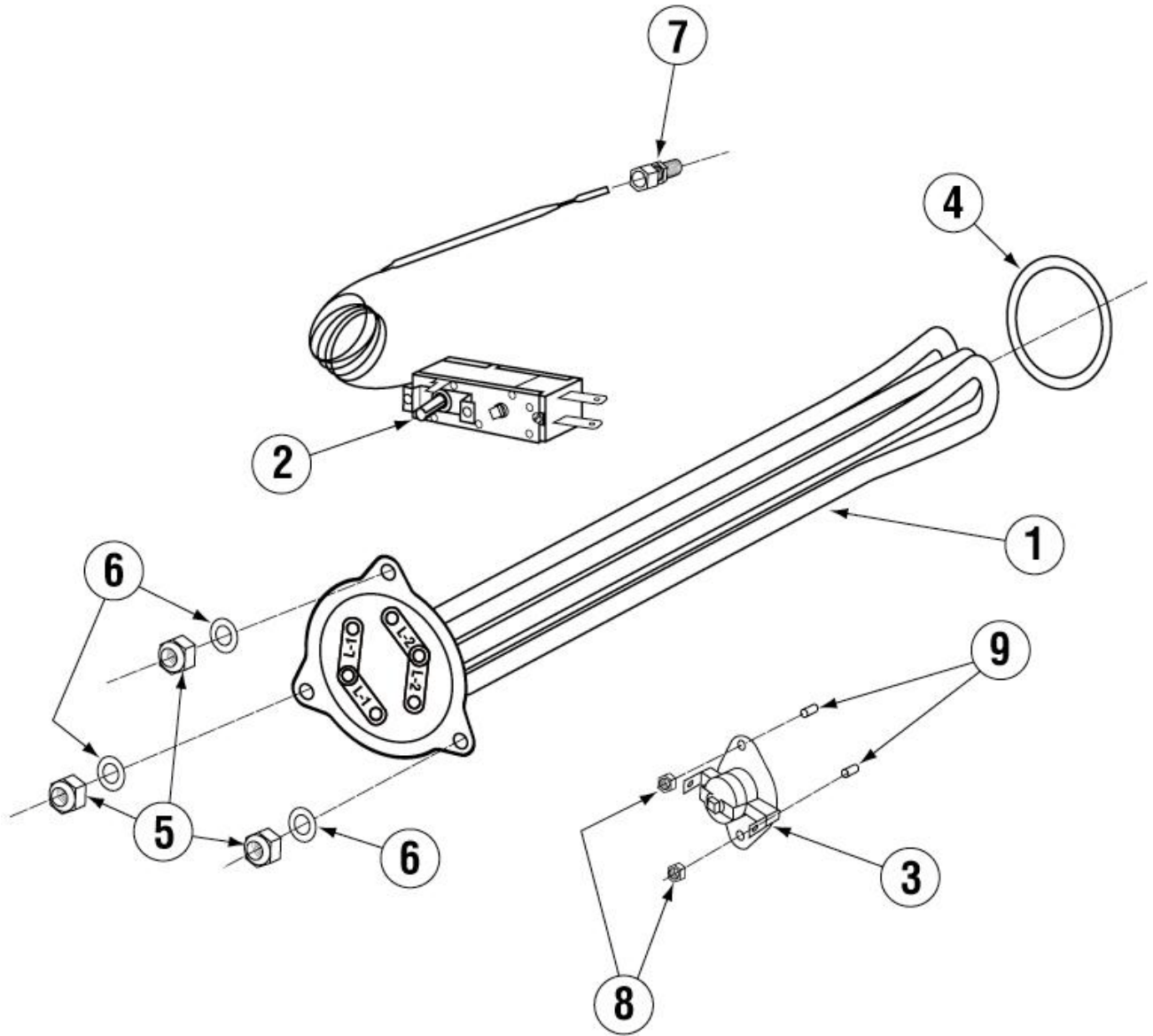

ITEM NO.	NO. REQ'D	P/N	DESCRIPTION
1	1	15518.00	Heater 6kW 220V Triangular Flange*
2	1	13417.89	Heater Thermostat
3	1	17523.60	High Limit Switch 200°F
4	1	15518.11	Gasket for Triangular Flange Heater
5	3	13805.00	5/16"-18 Nylon Insert Lock Nut

ITEM NO.	NO. REQ'D	P/N	DESCRIPTION
6	3	00926.00	5/16" SS Washer
7	1	40116.00	1/4" Compression x 1/4" MIP FTG
8	2	00965.00	6-32 Lock Nut
9	2	17524.00	High Limit Switch Spacer

* Gasket included

1.2.15. Drain Valve

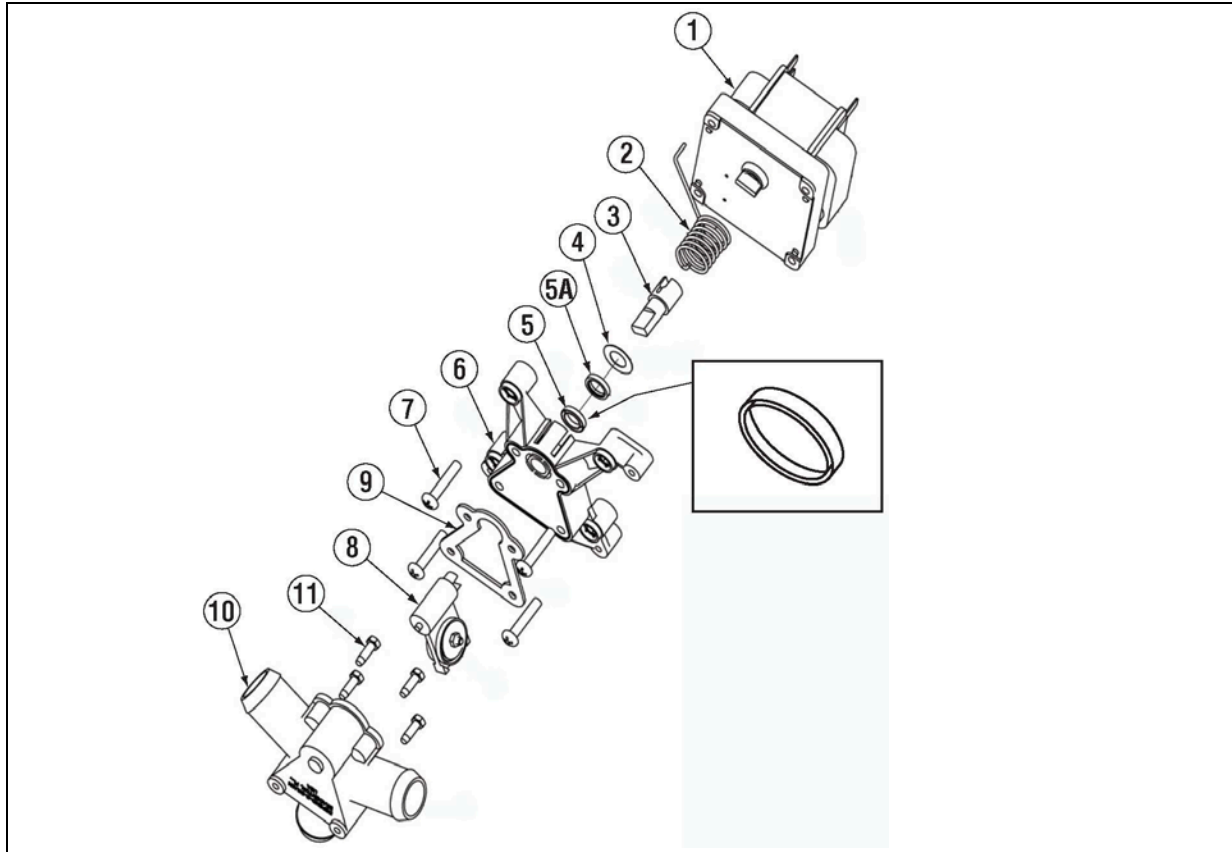

ITEM NO.	NO. REQ'D	P/N	DESCRIPTION
1	1	00104.50	Drain Motor 120V
2	1	04103.14	Drain Valve Spring
3	1	04103.20	Drain Valve Drive Pin
4	1	04103.19	Drain Valve Washer (Thin) SS
5	1	04103.17	Drain Valve Seal Washer (Rubber)
5A	1	04103.23	Drain Seal Bearing (White Washer)
6	1	04113.33	Drain Valve Housing Cover
7	4	04113.18	Valve Cover Screw
8	1	04113.16	Drain Valve Hinge/Seal
9	1	04103.15	Drain Valve Housing Gasket
10	1	04113.12	Drain Valve Housing (Includes #11&12)
11	2	04113.21	Screw #6-32 X 0.625 Flanged Hex
12	2	04113.23	Screw - #6-32 X 1.5" Flanged Hex
13	1	04113.13	Valve Cover Assy. Rectangular