



# MODEL CMA-181GW

PARTS MANUAL

Rev 1.01B 12-2022



**CMA DISHMACHINES**  
**12700 KNOTT AVENUE**  
**GARDEN GROVE, CALIFORNIA 92841**  
**800-854-6417**  
**FAX 714-895-2141**

[wwwcmadishmachines.com](http://wwwcmadishmachines.com)

[Buy Parts](#)

# TABLE OF CONTENTS

## MODEL CMA-181GW

<b>1. PARTS MANUAL</b> .....	<b>3</b>
1.1. INITIAL PARTS KIT (P/N 1100.66).....	3
1.2. MECHANICAL DRAWINGS .....	4
1.2.1. <i>Cabinet Assembly</i> .....	4
1.2.2. <i>Door Assembly</i> .....	5
1.2.3. <i>Electrical Tray</i> .....	6 & 7
1.2.4. <i>Control Box Assembly p/n 18611.62</i> .....	8
1.2.5. <i>Chemical Dispenser</i> .....	9 & 10
1.2.6. <i>Plumbing System Assembly (Effective August 2012)</i> .....	11
1.2.7. <i>Plumbing System Assembly</i> .....	12
1.2.8. <i>Drain System Assembly</i> .....	13
1.2.1. <i>Wash System</i> .....	14
1.2.2. <i>Rinse System</i> .....	15
1.2.3. <i>S/S Pump Assembly</i> .....	16
1.2.4. <i>Heater Assembly</i> .....	17 & 18
1.2.5. <i>Drain Valve</i> .....	19
1.2.6. <i>Water Tempering Kit (Optional)</i> .....	20



## 1. Parts Manual

### 1.1. Initial Parts Kit (P/N 1100.66)

P/N	DESCRIPTION	Qty
15504.00	Motor Contactor, 2-Pole 20 Amp	1
15504.50	Heater Contactor, 2-Pole 35 Amp	1
00501.00	2-Minute Timer Motor	1
00631.00	Ice Cube Relay 120 V	1
00707.00	½ Water Solenoid Repair Kit JE	1
00738.15	Solenoid Coil JE 220V	1
15523.00	Rocker Switch Start Momentary	1
15523.50	Rocker Switch Drain/Fill	1
15524.00	Rocker Switch Power Maintained	1
00556.10	Reed Switch	1
03623.00	1/2" Vacuum Breaker Repair Kit – Watts	1
00707.00	1/2" Water Solenoid Repair Kit – J/E	1
04113.00	L1X/L1-C Drain Valve 120V	1
00206.70	Pump Seal Kit	1
13417.89	Heater Thermostat	1
17523.60	High Limit Switch 200°F	1
00411.00	Microswitch	1
03203.01	Dual Temperature Display Kit	1
00738.15	Solenoid Coil JE 115V/60Hz	1

## 1.2. Mechanical Drawings

### 1.2.1. Cabinet Assembly

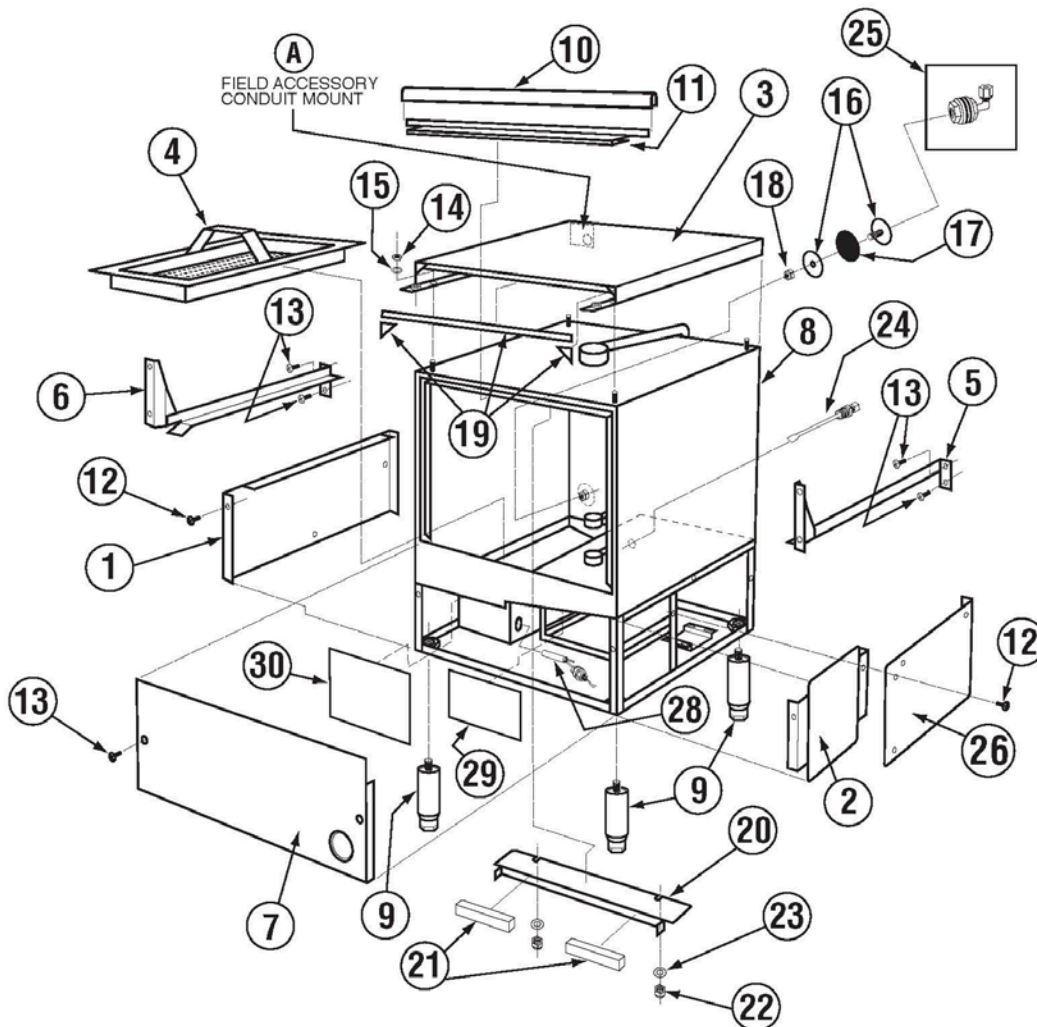

ITEM NO.	NO. REQ'D	P/N	DESCRIPTION
1	1	14502.83	Side Panel L.H. for CMA-181GW
2	1	14508.11	Peri Pump Front R Side Cover(181GW)
3	1	14503.40	SS Top for CMA-180UC
4	1	14510.00	Scrap Basket for CMA-180UC
5	1	14511.00	Tray Track R.H. for CMA-180UC
6	1	14512.00	Tray Track L.H. for CMA-180UC
7	1	14515.22	Lower Front Panel for CMA-181GW
8	1	14601.00	SS Body CMA-181 GW
9	4	01146.00	^Leg 6" 1/2 -13 Thread
10	1	14506.50	Door Gasket for CMA-180UC
11	1	14506.45	Gasket Bracket for CMA-180UC
12	6	00940.50	10-32 x 3/8 Trusshead Screw
13	8	00941.00	10-32 x 5/8 Panhead Screw
14	4	03801.00	10-32 Lock Nut
15	4	00940.51	#10 Internal Lock Star Washer

ITEM NO.	NO. REQ'D	P/N	DESCRIPTION
16	1	01513.00	Detergent Injection Hole Plug
17	1	00752.00	Detergent Injection Hole Plug Gasket
18	1	00912.00	1/4"-20 Nylon Lock Nut
19	2ft	03705.84	Control Box Gasket for CMA-180UC
20	1	14558.00	Body Magnet Holder for CMA-180UC
21	2	00557.80	Magnet for CMA-180UC
22	2	00927.00	8-32 Lock Nut
23	2	04806.00	#10 Brass Flat Washer
24	1	03204.50	Thermo well Ass'Y Cma-180UC (Wash)
25	1	03415.00	Chemical Bulk Head
26	1	14508.21	Peri Pump Back R Side Cover (180GW)
27	4	01147.50	Leg 4" 1/2-13 1" Diameter (UC)
28	1	13463.10	Liquid Level Switch
29	1	03705.21	Timer Splash Shield Mylar
30	1	03705.25	Heater Splash Shield Mylar

1.2.2. Door Assembly

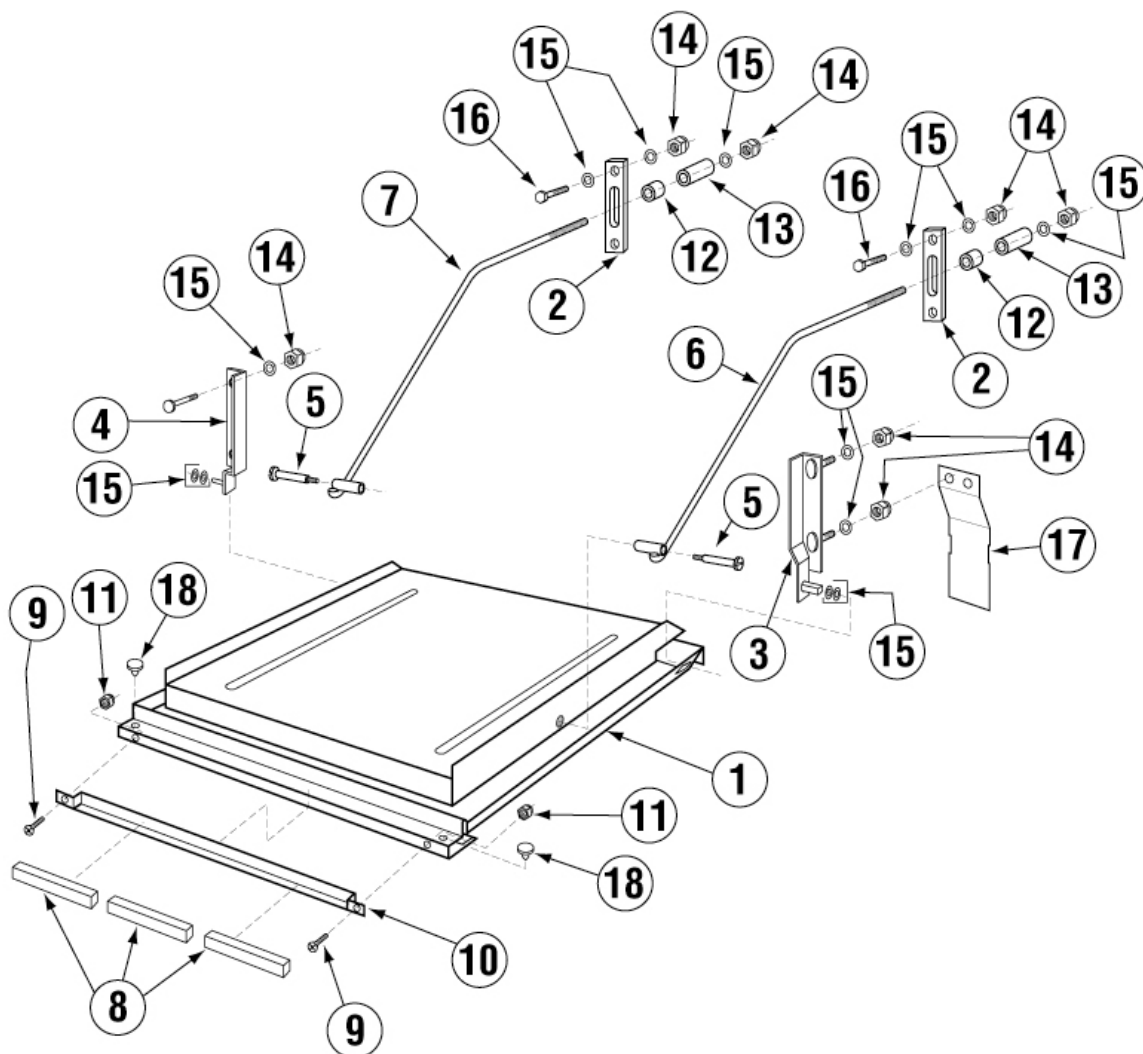

ITEM NO.	NO. REQ'D	P/N	DESCRIPTION
1	1	04907.90	L-1X Door New (7/2002)
2	2	04517.60	Door Support Rod Block
3	1	14570.00	Door Hinge R.H. for CMA-180UC
4	1	14570.50	Door Hinge L.H. for CMA-180UC
5	2	04919.00	Door Rod Screw Pin for CMA-180UC
6	1	04918.60	Door Support Rod Right
7	1	04919.50	Door Support Rod Left
8	3	00557.80	Door Magnet
9	2	00970.60	6-32 x 1/2" Flathead Screw

ITEM NO.	NO. REQ'D	P/N	DESCRIPTION
10	1	14558.61	Door Magnet Holder for CMA-180UC
11	2	00965.00	6-32 Lock Nut
12	2	00605.30	Door Rod Spacer
13	2	04517.15	Door Stop (Parallel)
14	10	00912.00	1/4"-20 Nylon Lock Nut
15	14	00924.00	1/4" SS Washer
16	4	00914.10	1/4"-20 x 5/8" Hexhead Bolt
17	2	14518.00	Splash Guard

# Parts Manual

## 1.4.3. Electrical Tray

Effective January 2021

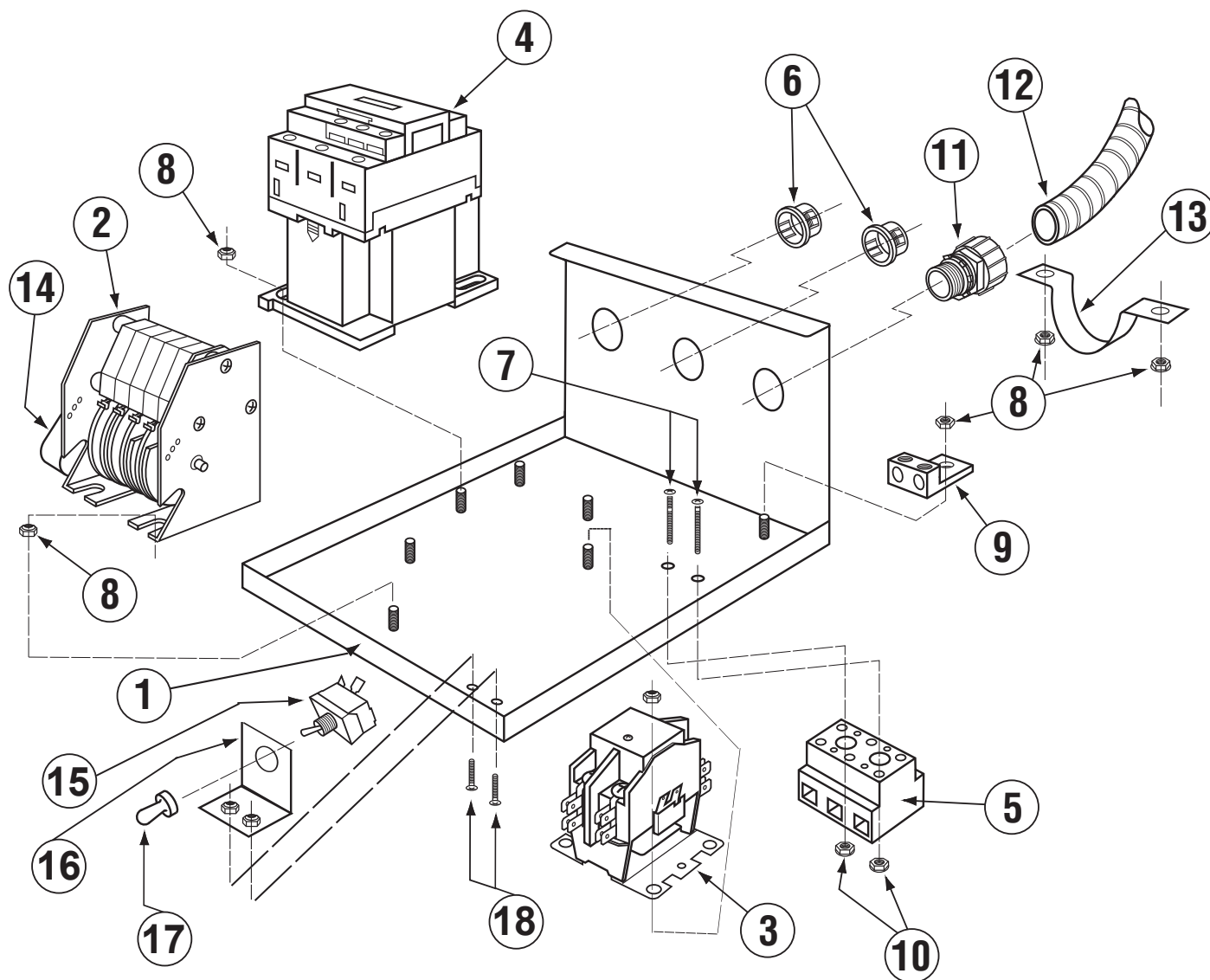

ITEM NO.	NO. REQ'D	P/N	DESCRIPTION
1	1	14504.00	Electrical Tray for CMA-180UC
2	1	14408.87	Timer 2 Min 7 Cam 180-UC S.T
3	1	15504.00	Motor Contactor, 2-Pole 20 Amp
4	1	15504.50	Heater Contactor, 2-Pole 35 Amp
5	1	15520.50	Power Block, 3-Position
6	2	00438.00	Snap Bushing, Universal
7	2	01001.00	6-32 x 1" Panhead Screw
8	12	00927.00	8-32 Nylon Lock Nut
9	1	13426.60	Ground Block

ITEM NO.	NO. REQ'D	P/N	DESCRIPTION
10	2	00965.00	6-32 Lock Nut
11	1	00401.85	3/4" Conduit Connector, Straight
12	9	00400.85	3/4" Conduit, Sealtite
13	1	00401.85	HT Plumbing Bracket
14	1	00400.85	Timer Motor
15	1	00471.10	Toggle Switch DPST 20A
16	1	00474.00	Toggle Switch Bracket
17	1	00470.10	Toggle Switch Rubber Boot
18	2	00907.00	6-32 x 1/2" Panhead Screw

1.2.3. Electrical Tray

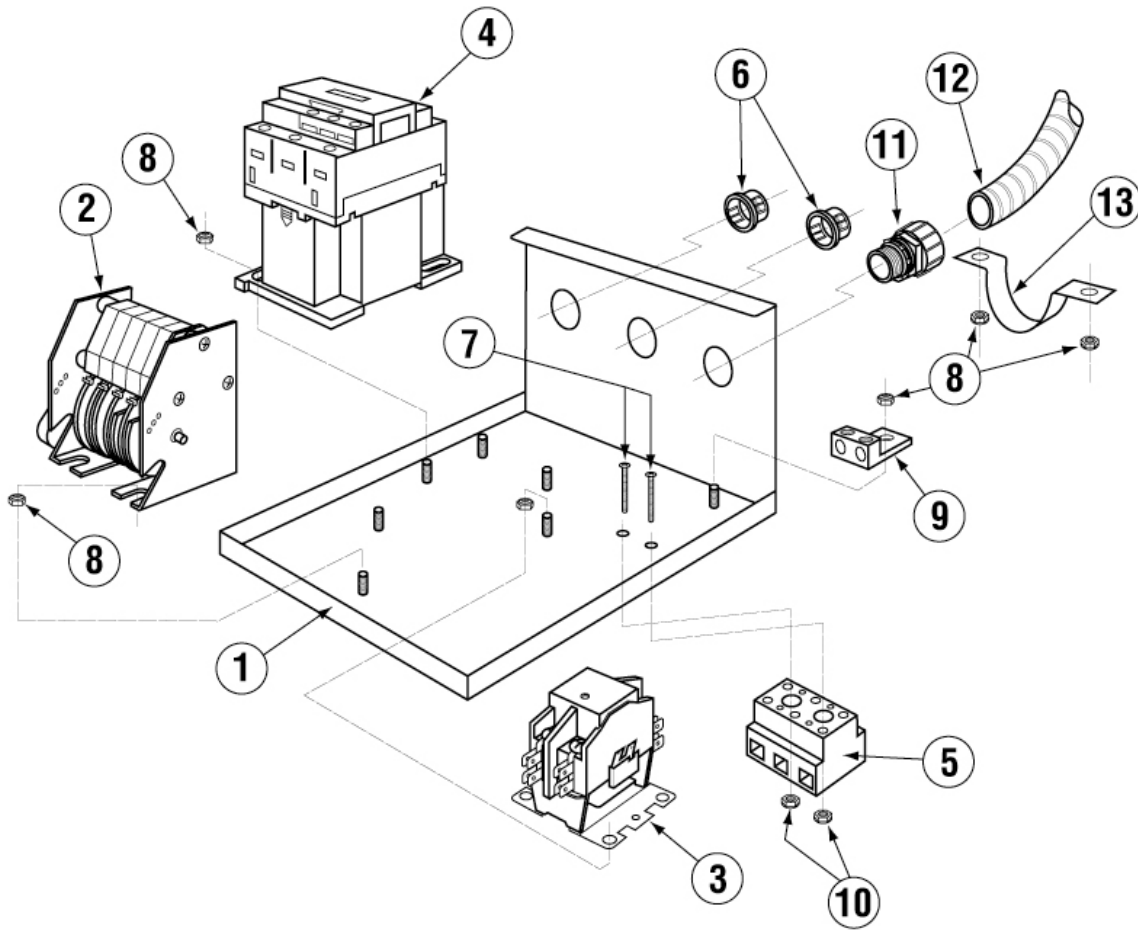

ITEM NO.	NO. REQ'D	P/N	DESCRIPTION
1	1	14504.00	Electrical Tray for CMA-180UC
2	1	14408.81	Timer 2Min 5 Cam 180-UC S.T
3	1	15504.00	Motor Contactor, 2-Pole 20 Amp
4	1	15504.50	Heater Contactor, 2-Pole 35 Amp
5	1	15520.50	Power Block, 3-Position
6	2	00438.00	Snap Bushing, Universal
7	2	01001.00	6-32 x 1" Panhead Screw

ITEM NO.	NO. REQ'D	P/N	DESCRIPTION
8	12	00927.00	8-32 Nylon Lock Nut
9	1	13426.60	Ground Block
10	2	00965.00	6-32 Lock Nut
11	1	00401.85	3/4" Conduit Connector, Straight
12	9	00400.85	3/4" Conduit, Sealtite
13	1	13304.61	HT Plumbing Bracket



1.2.4. Control Box Assembly p/n 18611.62

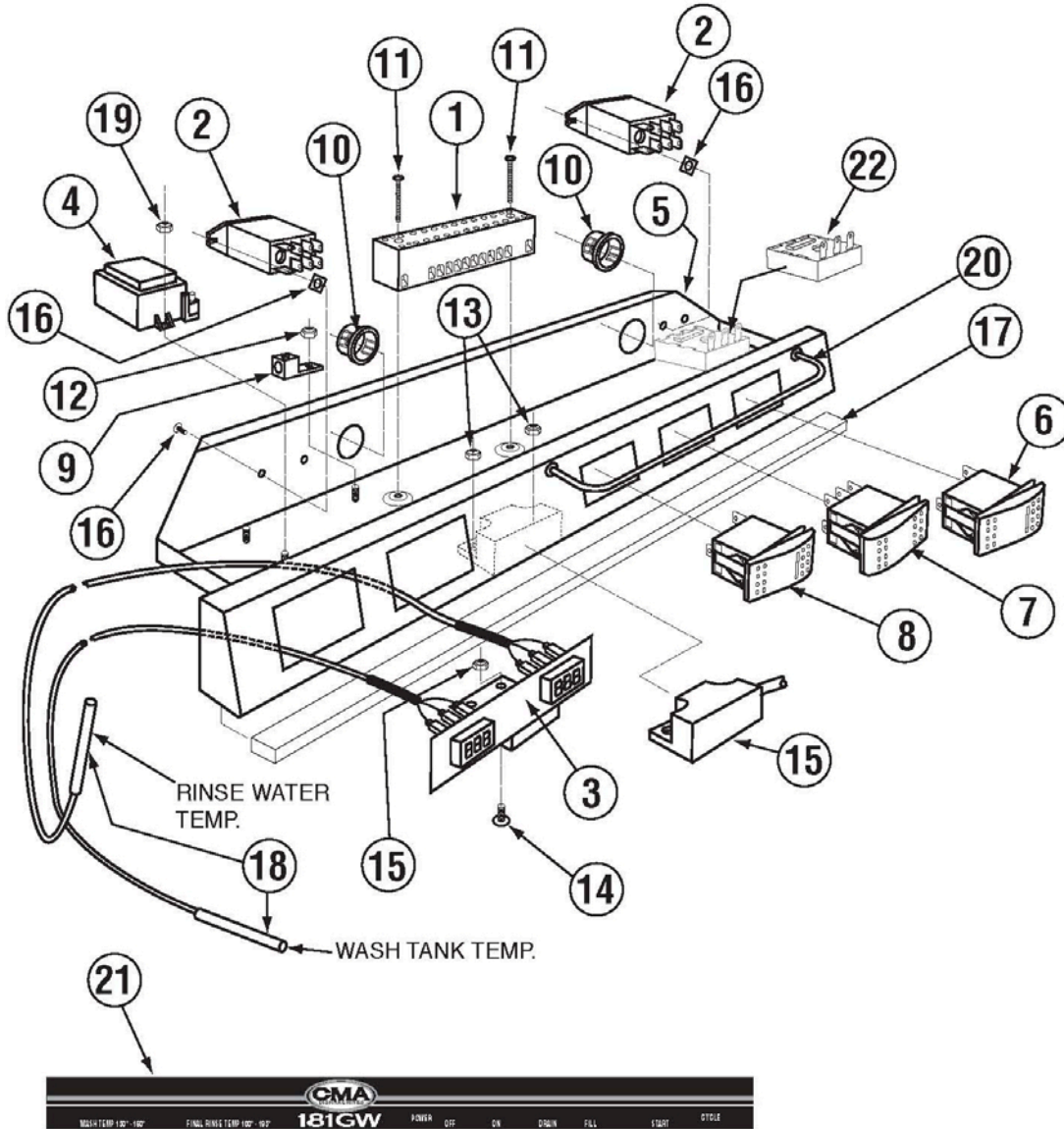

ITEM NO.	NO. REQ'D	P/N	DESCRIPTION
1	1	15520.00	Power Block 12-Position
2	2	00631.00	Ice Cube Relay 120 V
3*	1	03203.01	Dual Temperature Display Kit
4	1	03202.60	Thermometer Transformer
5	1	14503.00	Control Drawer for CMA-180UC
6	1	15523.00	Rocker Switch Start Momentary *
7	1	15523.50	Rocker Switch Drain/Fill DPDT/Mom. *
8	1	15524.00	Rocker Switch Power Maintained *
9	1	13426.50	Ground Block
10	1	00438.00	Snap Bushing, Universal
11	2	01001.00	6-32 x 1" Panhead Screw

ITEM NO.	NO. REQ'D	P/N	DESCRIPTION
12	2	00965.00	6-32 SS Nylon Lock Nut
13	5	00927.00	8-32 Nylon Lock Nut
14	6	00911.00	8-32 x 1/2" Panhead Screw
15	1	00556.10	Reed Switch
16	4	00917.00	8-32 PM Nut
17	2	03705.82	Sponge Strip
18	2	03202.66	Thermocouple
19	2	00971.10	4-40 Nylon Lock Nut
20	1	03485.00	Switch Guard (Undercounter)
21	1	06231.67	CMA-181GW Panel Label
22*	1	00630.50	Timer Relay 120V

\* Effective January 2017



## 1.2.5. Chemical Dispenser Assembly January 2021

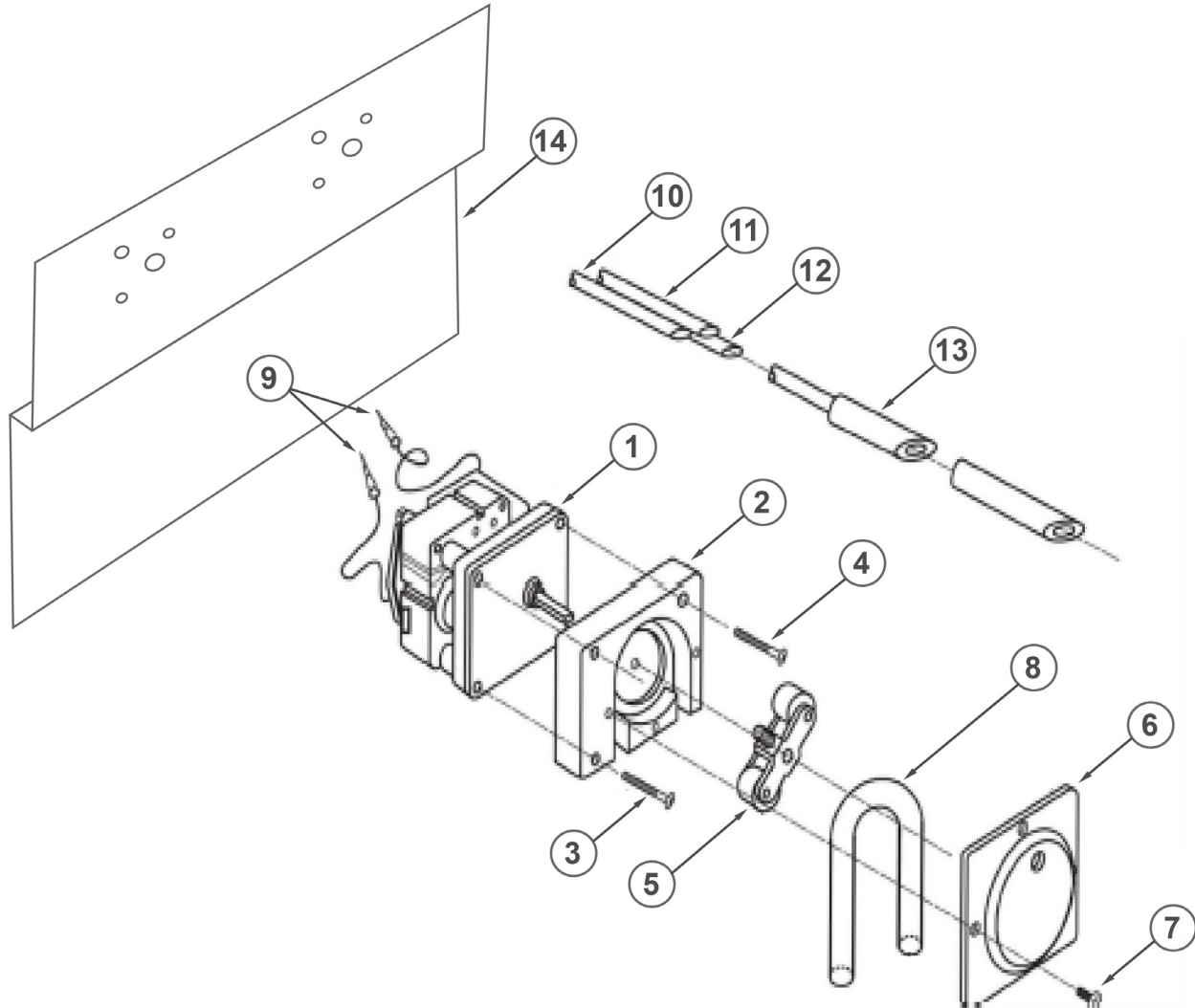

ITEM NO.	NO. REQ'D	P/N	DESCRIPTION
1	1	00416.00	Peristaltic Pump Motor
2	1	00417.10	Peristaltic Pump Block
3	1	00919.00	10-32x1-1/2" Pan Head Screw
4	1	00918.00	10-32x1-1/2" Fillister Head Screw
5	1	00419.00	Peristaltic Pump Rotor
6	1	00418.00	Peristaltic Pump Cover
7	1	00911.00	8-32x1/2" Pan Head Screw

ITEM NO.	NO. REQ'D	P/N	DESCRIPTION
8	1	02257.23	Squeeze Tube 11"
9	1	00448.00	Barrel Connector, Male
10	1	00425.23	Chemical Tubing, Red, 50 Ft Roll
11	1	00425.21	Chemical Tubing, Blue, 50 Ft Roll
12	1	00425.24	Chemical Tubing, White, 50 Ft Roll
13	1	00443.00	Tube Stiffener
14	1	14508.40	180UC Peri Pump Mount

1.2.5. Chemical Dispenser

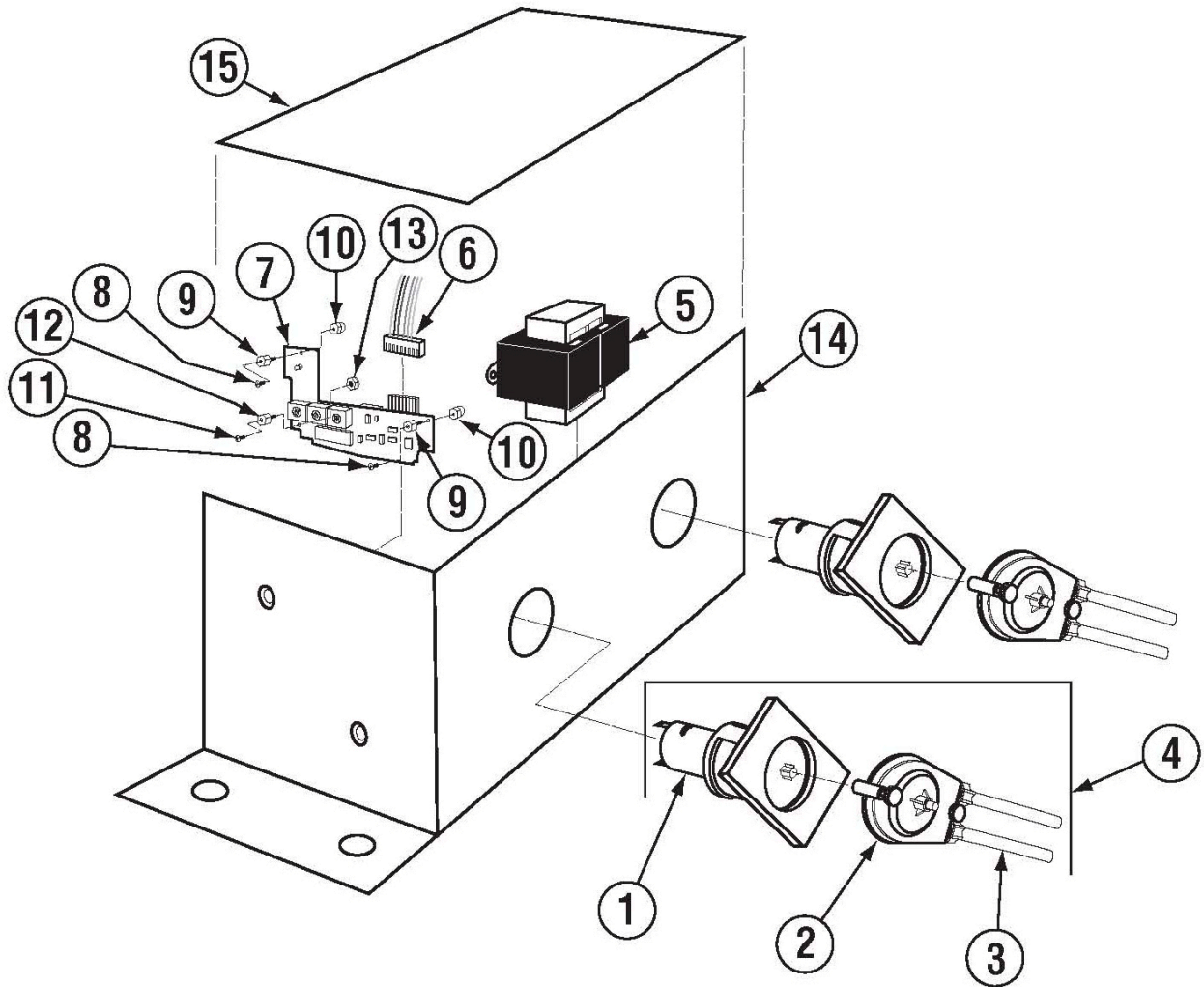

ITEM NO.	NO. REQ'D	P/N	DESCRIPTION
1	2	00816.00	Peri Pump Gear Motor (GL-C/GW-100)
2	2	00818.00	GL-C/GW-100 Peri Pump Cartridge
3	2	00839.00	GL-C/GW-100/UC180 Sqz Tube Clear
	2	00835.30	GL-C/GW-100/UC180 Sqz Tube Black
4	2	00815.00	GL-C Peri Pump Complete
5	1	00821.10	GL-C/GW-100 Transformer
6	2	00820.40	Circuit Board Connector
7	2	00820.00	GL-C/GW-100 Peri Pump Circuit Board

ITEM NO.	NO. REQ'D	P/N	DESCRIPTION
8	4	13826.47	4-40 x 3/16 Phil Pan Head Screw
9	4	00820.06	Circuit Board Standoff
10	4	00820.07	Circuit Board Standoff Cap
11	2	13826.00	4-40 X 5/8 Pan Head Screw
12	2	00820.50	Circuit Board Stand-off Bushing
13	2	00971.10	4-40 Nylon Lock Nut
14	1	14508.00	UC180 Peri Pump Box
15	1	14585.73	Dispenser Splash Shield

\*Effective May 2019

1.2.6. Plumbing System Assembly (Effective August 2012)

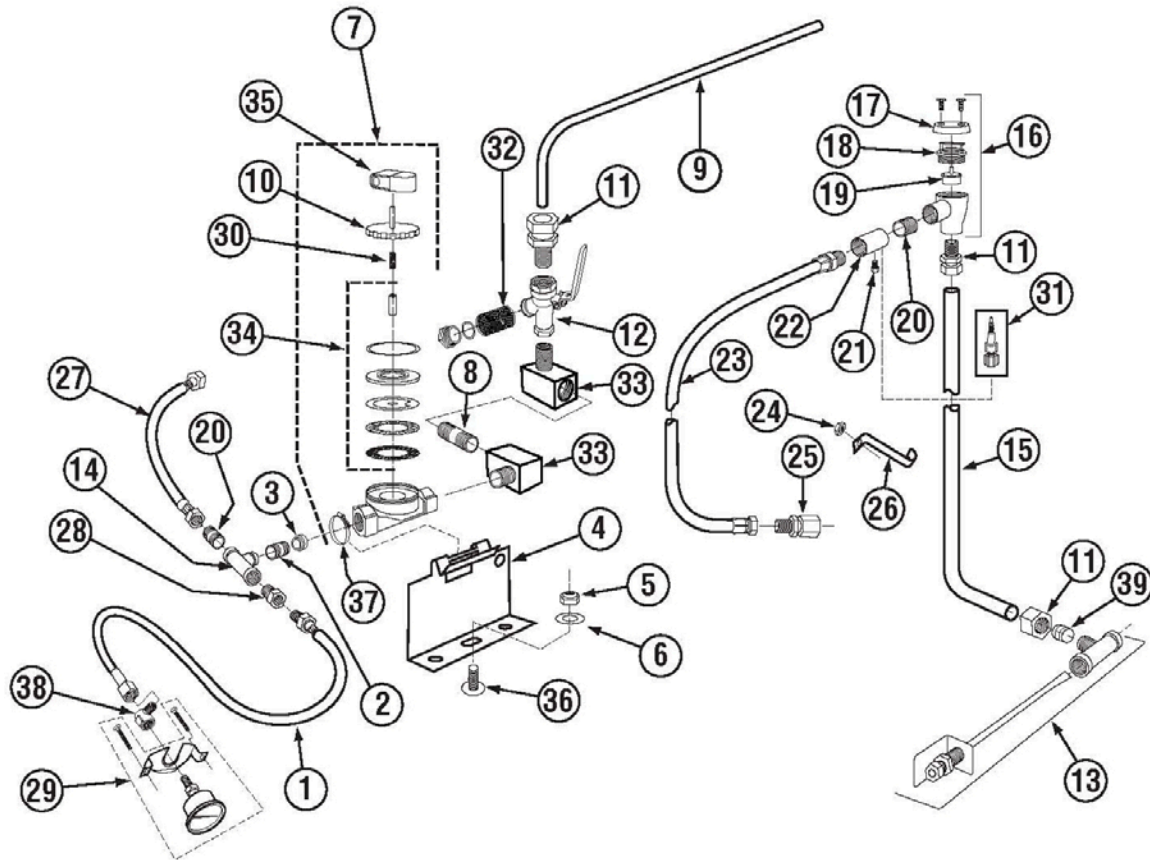

ITEM NO.	NO. REQ'D	P/N	DESCRIPTION
1	1	15602.00	SS Braided Hose 20" 1/2 F x 1/4MPT
2	1	03614.00	Nipple Brass 1/2 x Close
3	1	03604.50	Fitting w/ Flow Disk
4	1	14508.50	Plumbing Bracket
5	1	03801.00	10-32 Lock Nut
6	2	00924.00	1/4 SS Washer
7	1	03603.10	1/2 Water Sol Valve JE115V/60Hz
8	1	00747.00	Nipple Brass 1/2x4
9	1	03605.10	Plumbing tube CMA-181GW
10	1	03603.20	1/2" Water Solenoid Valve Bonnet
11	4	00770.10	5/8 Compression Fitting Nut
12	1	41062.00	1/2" Strainer Ball Valves *
13	1	03205.00	Thermo well Tee
14	1	00743.11	1/2 Tee FxFx F SS
15	1	05007.60	Vacuum Breaker Line
16	1	03624.00	1/2" Vacuum Breaker – Watts
17	1	00739.50	Vacuum Breaker Cap, SS
18	1	03624.25	Vacuum Breaker Bonnet, Brass
19	1	03623.00	1/2" Vac. Breaker Repair Kit – Watts
20	2	03614.00	Nipple, Brass 1/2" Close

ITEM NO.	NO. REQ'D	P/N	DESCRIPTION
21	1	03232.00	1/8" Male Plug
22	1	13669.45	SS Mixing Chamber CMA-180UC
23	1	00798.00	1/2" SS Braided Hose
24	2	00915.00	1/4"-20 SS Nut
25	2	00724.00	1/2" Compression x 1/2" MIP Adapter
26	1	13304.53	Long Support Bracket
27	1	00798.60	SS Braided Hose 7"
28	1	13604.10	1/2 x 1/8 Bushing Brass
29	1	13605.45	Pressure Gauge for CMA-180UC
30	1	00706.10	Solenoid JE Spring Only
31	1	13658.00	Inlet Check Valve
32	1	41062.10	Ball Strainer
33	2	00745.00	1/2 90 Deg Street Elbow
34	1	00707.00	1/2 Water Solenoid Repair Kit JE
35	1	00738.15	Solenoid Coil JE 220V (3/4 & 1/2)
36	1	00940.50	10-32 x 3/8 Truss Head Screw
37	1	03101.45	Hose Clamp #4 Size #002 SS
38	1	40137.00	1/4 Street Elbow 90Deg
39	1	00770.20	5/8 Compression Fitting Ring

1.2.7. Plumbing System Assembly

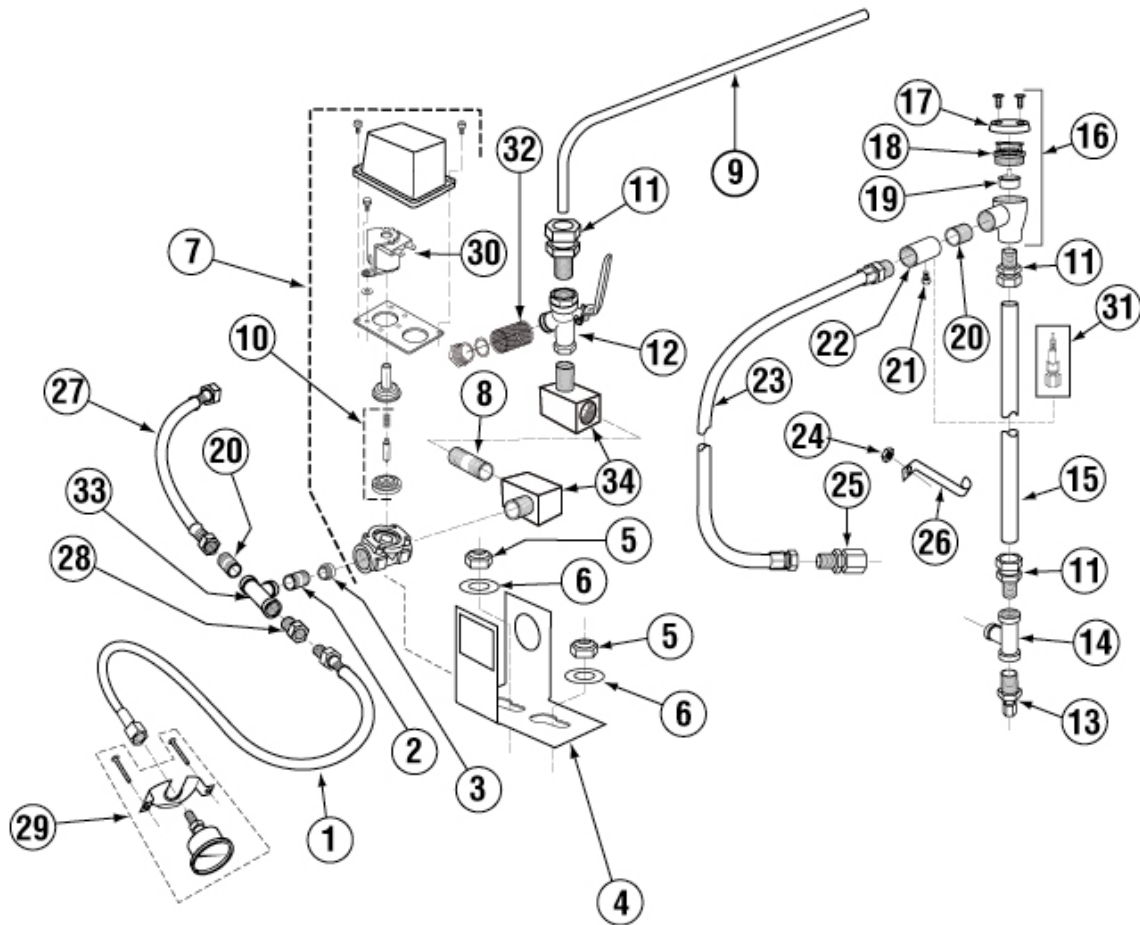

ITEM NO.	NO. REQ'D	P/N	DESCRIPTION
1	1	15602.00	SS Braided Hose 20" 1/2 F x 1/4MPT
2	1	03614.00	Nipple Brass 1/2 x Close
3	1	03604.50	Fitting w/ Flow Disk
4	1	05907.00	Valve Bracket
5	2	00912.00	1/4-20 Nylon Lock Nut
6	2	00924.00	1/4 SS Washer
7	1	03604.00	SS Water Solenoid Valve 1/2"
8	1	00747.00	Nipple Brass 1/2x4
9	1	03605.10	Plumbing tube CMA-181GW
10	1	03604.30	Dema Valve Repair Kit 1/2"
11	4	00760.00	5/8" Compression x 1/2" MIP Adapter
12	1	41062.00	1/2" Strainer Ball Valves *
13	1	00214.60	1/4" Compression x 1/2" MIP FTG
14	2	00743.11	1/2 Tee FxFx F SS
15	1	05007.60	Vacuum Breaker Line
16	1	03624.00	1/2" Vacuum Breaker – Watts
17	1	00739.50	Vacuum Breaker Cap, SS

ITEM NO.	NO. REQ'D	P/N	DESCRIPTION
18	1	03624.25	Vacuum Breaker Bonnet, Brass
19	1	03623.00	1/2" Vac. Breaker Repair Kit – Watts
20	2	03614.00	Nipple, Brass 1/2" Close
21	1	03232.00	1/8" Male Plug
22	1	13669.45	SS Mixing Chamber CMA-180UC
23	1	00798.00	1/2" SS Braided Hose
24	2	00915.00	1/4"-20 SS Nut
25	2	00724.00	1/2" Compression x 1/2" MIP Adapter
26	1	13304.53	Long Support Bracket
27	1	00798.60	SS Braided Hose 7"
28	1	13604.10	1/2 x 1/8 Bushing Brass
29	1	13605.45	Pressure Gauge for CMA-180UC
30	1	41015.60	Water Solenoid Coil Only
31	1	13658.00	Inlet Check Valve
32	1	41062.10	Ball Strainer
33	1	00743.10	1/2 Tee FxFx F Brass
34	2	00745.00	1/2 90 Deg Street Elbow

1.2.8. Drain System Assembly

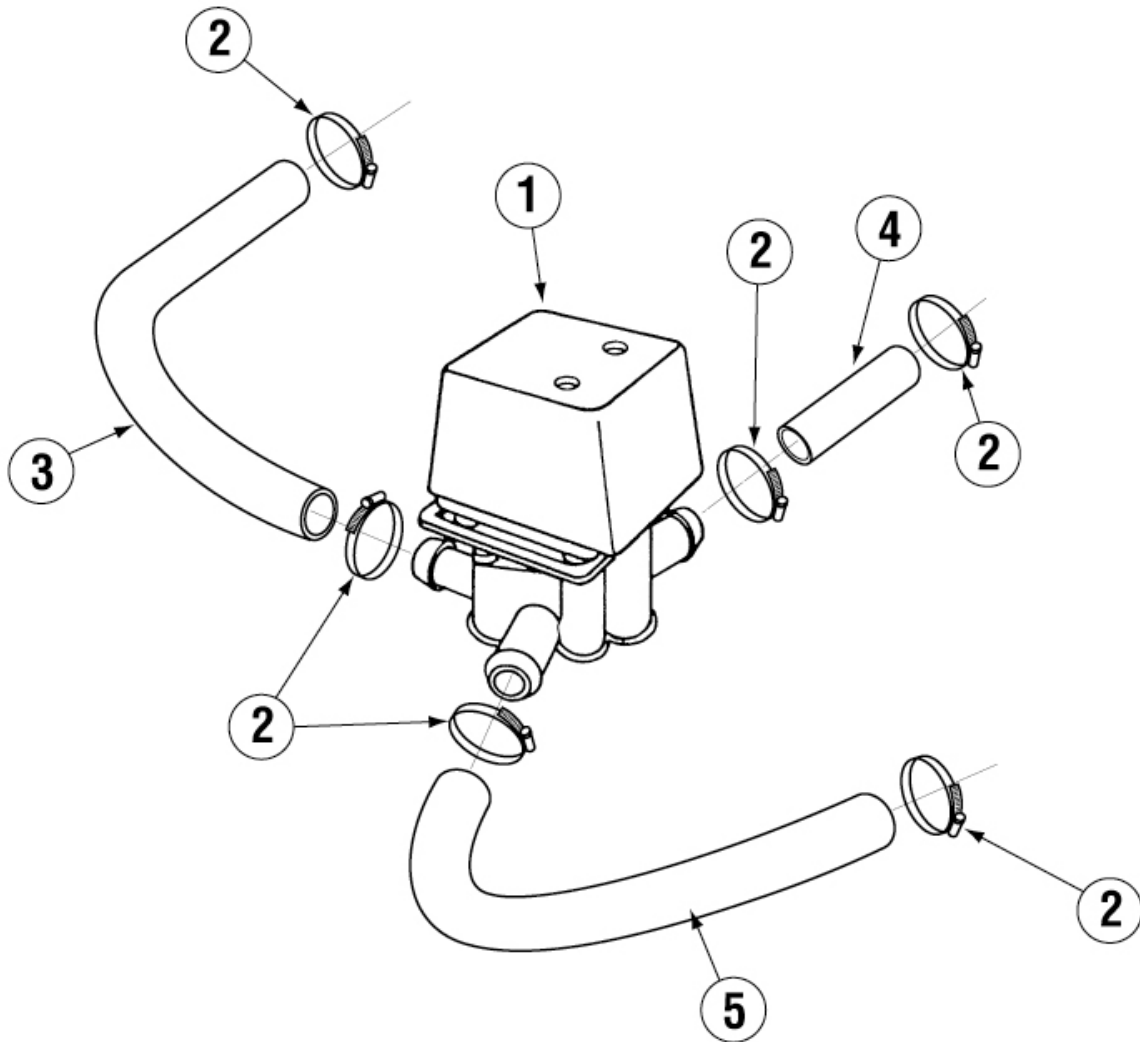

ITEM NO.	NO. REQ'D	P/N	DESCRIPTION
1	1	04113.00	Drain Valve 120V
2	6	03101.00	Hose Clamp #16-1"
3	1	03109.00	Transfer Hose 90Deg 1"

ITEM NO.	NO. REQ'D	P/N	DESCRIPTION
4	1	15601.00	Hose 1" ID 90Deg 3X11
5	1	N / A	Raw Material

1.2.1. Wash System

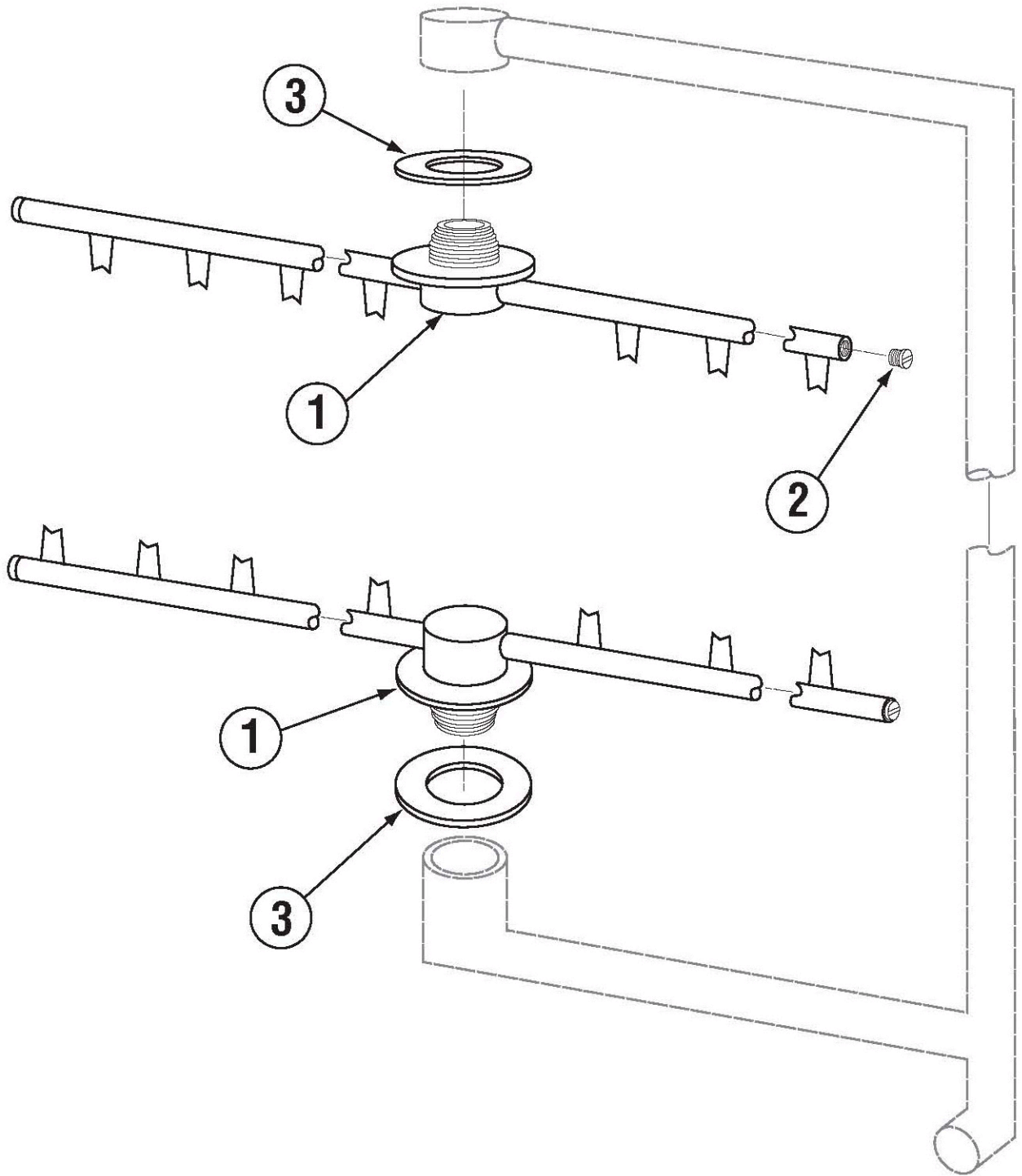

ITEM NO.	NO. REQ'D	P/N	DESCRIPTION
1	2	00304.46	Wash Arm
2	4	00308.20	Wash Arm End Plug

ITEM NO.	NO. REQ'D	P/N	DESCRIPTION
3	2	04305.17	Red Silicon Gasket 1/16" Thick



1.2.2. Rinse System

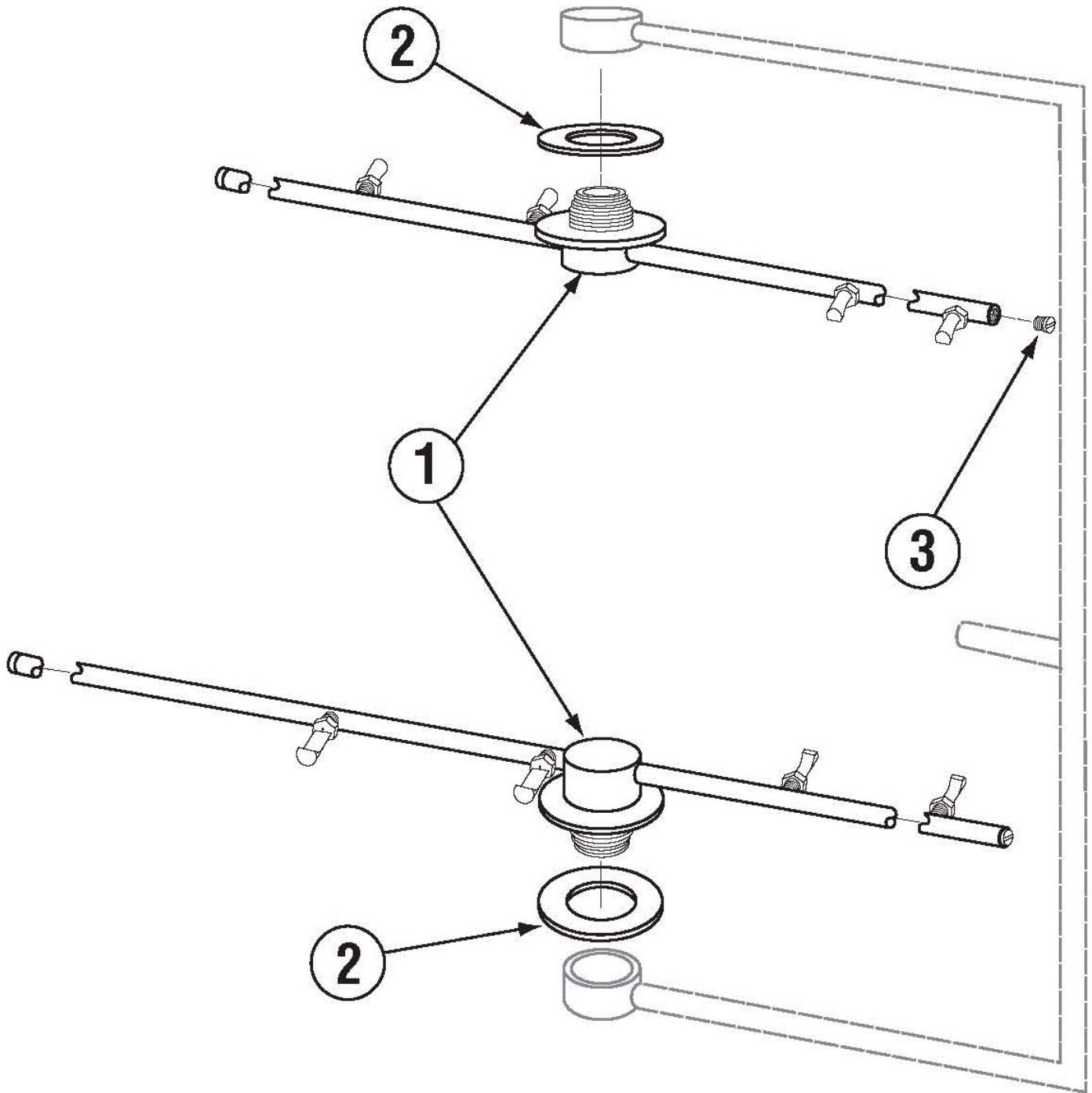

ITEM NO.	NO. REQ'D	P/N	DESCRIPTION
1	2	00304.29	Rinse Arm CMA-180UC
2	2	04305.17	Red Silicon Gasket 1/16" Thick

ITEM NO.	NO. REQ'D	P/N	DESCRIPTION
3	4	00308.17	Rinse Arm End Cap



1.2.3. S/S Pump Assembly

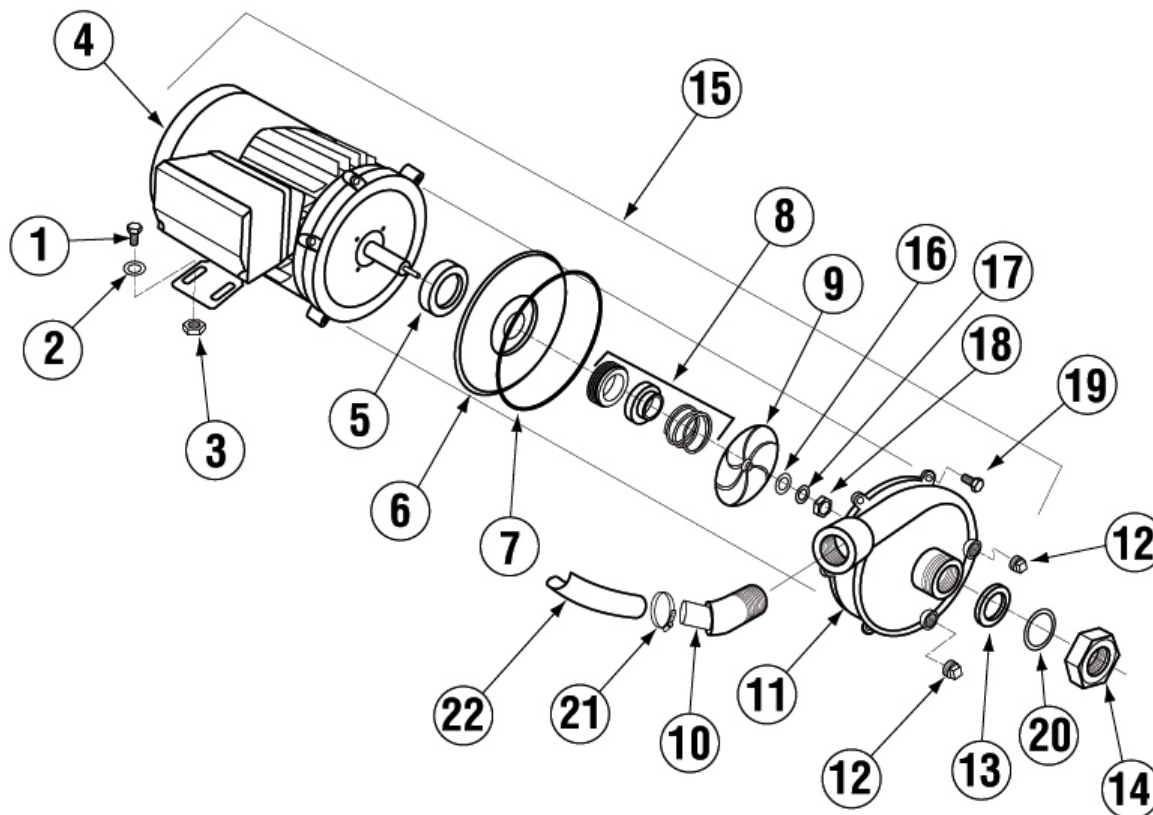

ITEM NO.	NO. REQ'D	P/N	DESCRIPTION
1	4	00908.00	5/16"-18 x 5/8" SS Hexhead Bolt
2	4	00926.00	5/16" SS Washer
3	4	00913.00	5/16"-18 Hex Nut
4	1	00201.60	SS Wash Pump Motor 220v
5	1	00201.96	Slinger Washer Cone Shape
6	1	03224.60	SS Pump Backplate
7	1	03226.70	Volute O-Ring For SS Pump
8	1	00206.70	SS Pump Seal Kit
9	1	03222.70	SS Pump Impeller
10	1	04604.00	^35 Deg Elbow MIP X Barb
11	1	04206.75	SS Pump Cover

ITEM NO.	NO. REQ'D	P/N	DESCRIPTION
12	2	00238.00	3/8" Male Plug
13	1	00208.40	Slip Joint Nut O Ring Buna
14	1	00207.00	Slip Joint Nut 1 1/2 x 1 1/4
15	1	00200.70	Includes Items 4,5,6,7,8,9,and 11
16	1	03222.74	Flat Washer 8 mm
17	1	03222.72	Shaft Nut Lock Washer 8mm
18	1	13809.70	SS Pump Seal Shaft Nut 8mm
19	6	00914.70	Socket Head Screw 10 mm
20	1	00208.21	Slip Joint Nut Friction Ring
21	1	03101.00	Hose Clamp # 16 1"
22	1	03108.62	Transfer Hose 1" Reinforce 25"

# Parts Manual

## 1.4.10. New Heater Assembly (Triangular Flange) After January 2020

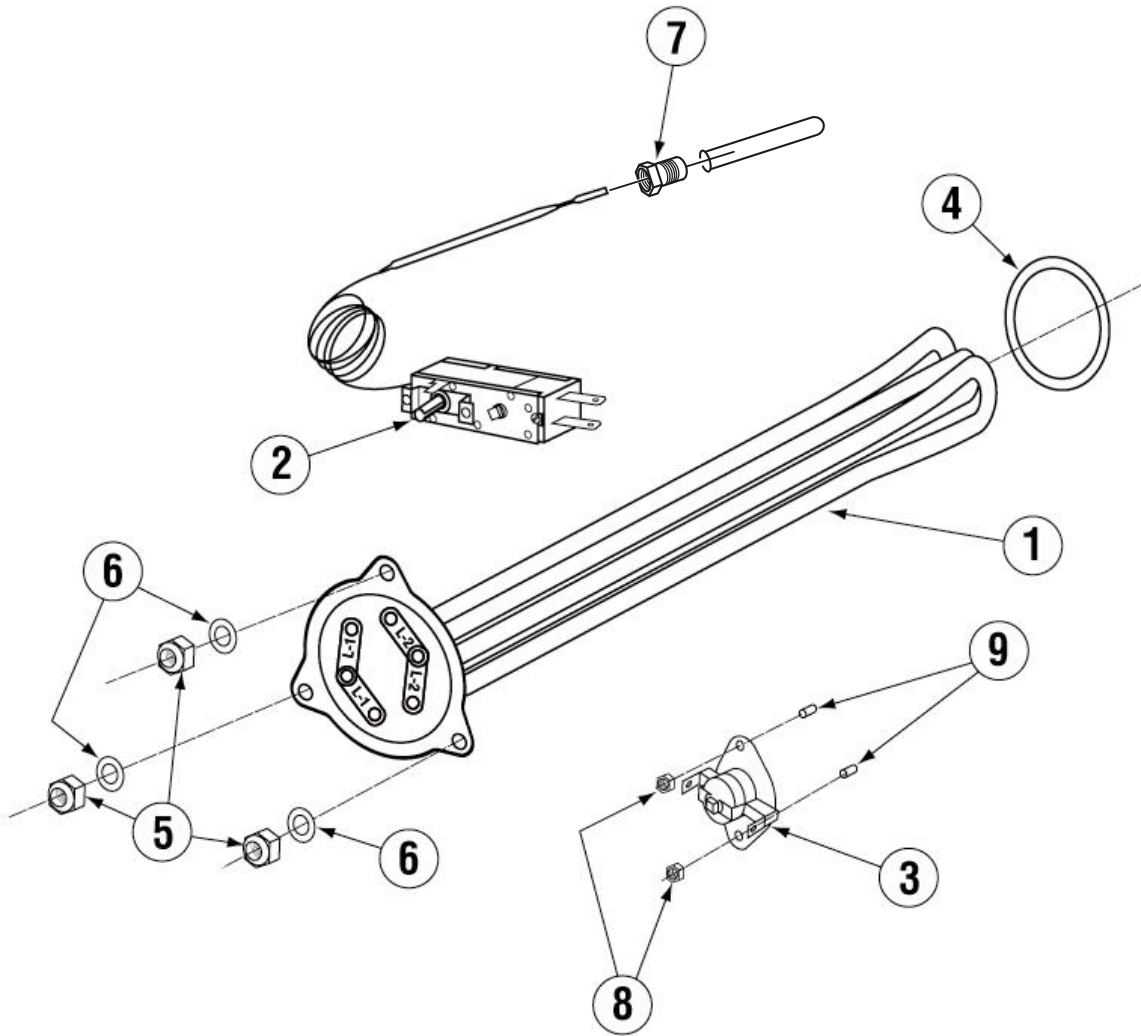

ITEM NO.	NO. REQ'D	P/N	DESCRIPTION
1	1	15518.00	Heater 6kW 220V Triangular Flange*
2	1	13417.89	Heater Thermostat
3	1	17523.60	High Limit Switch 200°F
4	1	15518.11	Gasket for Triangular Flange Heater
5	3	13805.00	5/16"-18 Nylon Insert Lock Nut

ITEM NO.	NO. REQ'D	P/N	DESCRIPTION
6	3	00926.00	5/16" SS Washer
7	1	13417.50	Thermowell Tube Assm
8	2	00965.00	6-32 Lock Nut
9	2	17524.00	High Limit Switch Spacer

\* Gasket included

## 1.2.4. Heater Assembly

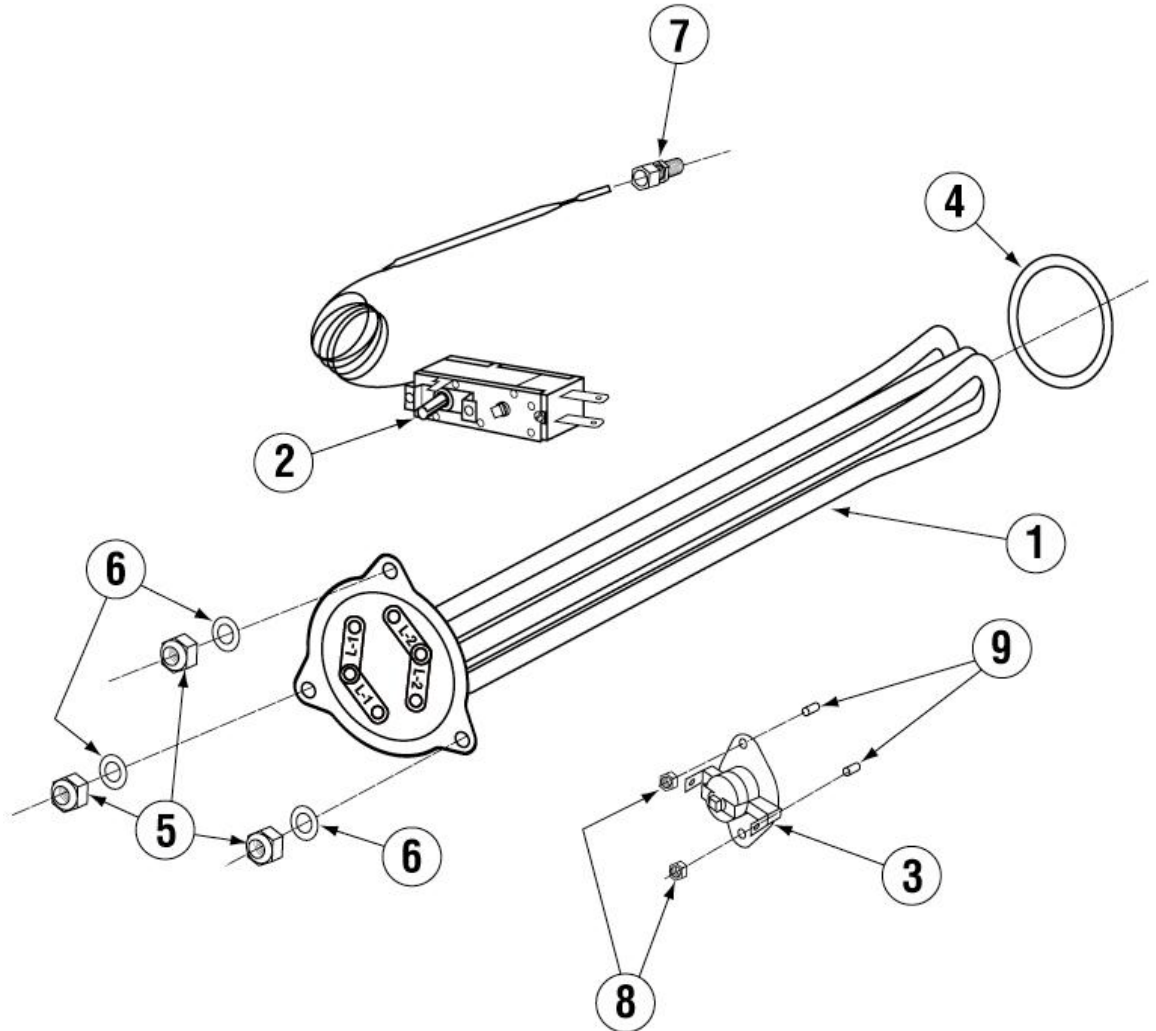

ITEM NO.	NO. REQ'D	P/N	DESCRIPTION
1	1	15518.00	Heater 6kW 220V Triangular Flange*
2	1	13417.89	Heater Thermostat
3	1	17523.60	High Limit Switch 200°F
4	1	15518.11	Gasket for Triangular Flange Heater
5	3	13805.00	5/16"-18 Nylon Insert Lock Nut

ITEM NO.	NO. REQ'D	P/N	DESCRIPTION
6	3	00926.00	5/16" SS Washer
7	1	40116.00	1/4" Compression x 1/4" MIP FTG
8	2	00965.00	6-32 Lock Nut
9	2	17524.00	High Limit Switch Spacer

\* Gasket included

1.2.5. Drain Valve

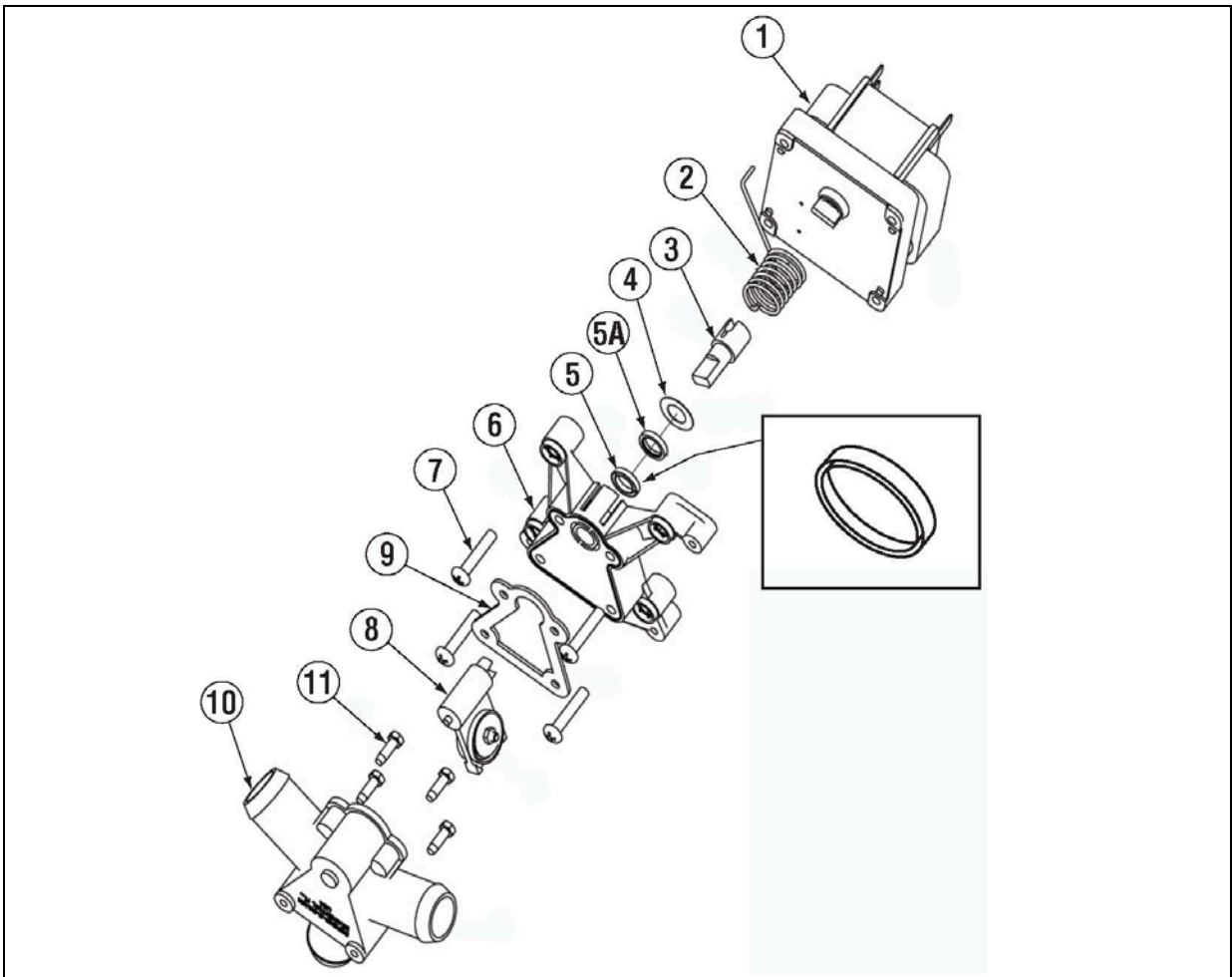

ITEM NO.	NO. REQ'D	P/N	DESCRIPTION
1	1	00104.50	Drain Motor 120V
2	1	04103.14	Drain Valve Spring
3	1	04103.20	Drain Valve Drive Pin
4	1	04103.19	Drain Valve Washer (Thin) SS
5	1	04103.17	Drain Valve Seal Washer (Rubber)
5A	1	04103.23	Drain Seal Bearing (White Washer)
6	1	04113.33	Drain Valve Housing Cover
7	4	04113.18	Valve Cover Screw
8	1	04113.16	Drain Valve Hinge/Seal
9	1	04103.15	Drain Valve Housing Gasket
10	1	04113.12	Drain Valve Housing ( Includes #11&12)
11	2	04113.21	Screw #6-32 X 0.625 Flanged Hex
12	2	04113.23	Screw - #6-32 X 1.5" Flanged Hex
13	1	04113.13	Valve Cover Assy. Rectangular

1.2.6. Water Tempering Kit (Optional)

181-GW & 181-GW-VL  
180UC Water Tempering Valve Kit  
P/N 13470.50

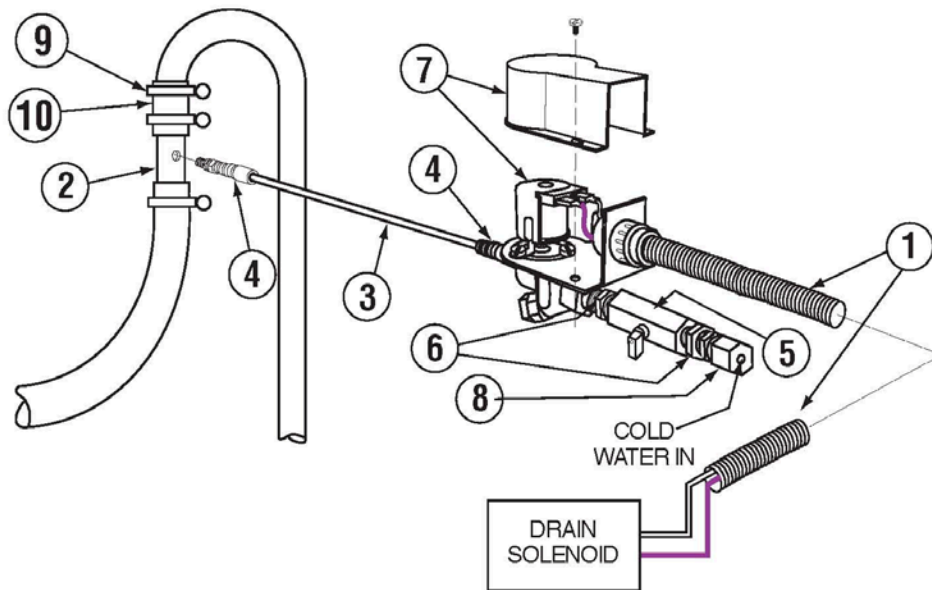

INSTALLATION INSTRUCTIONS TO DRAIN TEMPERING KIT

**NOTE:** Turn the dishwasher's wall breaker to "OFF" position before this installation.

1. Undo the drain hose clamp connecting the drain line gooseneck to drain hose leading to floor drain.
2. Install the water junction tee as shown on drain line gooseneck and tighten clamp.
3. Connect the drain hose to lower port of water injection tee and tighten hose clamp.
4. Insert the provided white chemical tube into compression nut of water injection tee and tighten compression nut.
5. Connect the provided cold-water solenoid's power leads to the drain solenoid.
6. Connect the water injection assembly's ball valve to a cold water supply.
7. Run the dishwasher through a few cycles and make sure the cold water is injected and check for any possible leaks.

ITEM NO.	P/N	NO REQ'D	DESCRIPTION
1.	15400.17	2.5	3/8" SPLIT RIBBED TUBING
2.	15603.50	1	GOOSE NECK PIPE ADAPTER TEE
3.	00425.54	2	CHEMICAL TUBING WHITE
4.	03415.50	2	FLEX-TIGHT FITTING
5.	41014.49	1	3/8" BALL VALVE
6.	40015.00	2	3/8" X 1/4" HEX BUSHING
7.	41015.00	1	SOLENOID VALVE 1/4" W/COVER 110V
8.	40116.00	1	1/4" COMP X 1/4" MIP FTG
9.	03101.00	3	HOSE CLAMP #16 1"
10.	03108.60	.25	TRANSFER HOSE 1" REINFORCED

5-2019