



MODEL UC50e

PARTS MANUAL

Rev 1.04 1-07-20



DISTRIBUTED EXCLUSIVELY BY
CMA DISHMACHINES
12700 KNOTT AVENUE
GARDEN GROVE, CALIFORNIA 92841

800-854-6417

FAX 714-895-2141

www.cmadishmachines.com

[Buy Parts](#)

TABLE OF CONTENTS
MODEL UC50E

PARTS MANUAL3

1.1. MECHANICAL DRAWINGS..... 3

 1.1.1. General Body Parts 3

 1.1.2. Lockup System 4

 1.1.3. Control Panel 5

 1.1.4. Control Components..... 6

 1.1.5. Solenoid Valve Group..... 7

 1.1.6. DVGW Assy. #02101.10 7

 1.1.7. Rinse Aid Dispenser Group 8

 1.1.8. Detergent Dispenser Group..... 9

 1.1.9. Boiler Group..... 10

 1.1.10. 3 Ways Connection 11

 1.1.11. Wash Pump..... 12

 1.1.12. Drain Pump Group..... 13

 1.1.13. Pressure Switch Group..... 13

 1.1.14. Turret Group..... 14

 1.1.15. Water Tempering Kit (Optional)..... 15

Parts Manual

1.1. Mechanical Drawings

1.1.1. General Body Parts

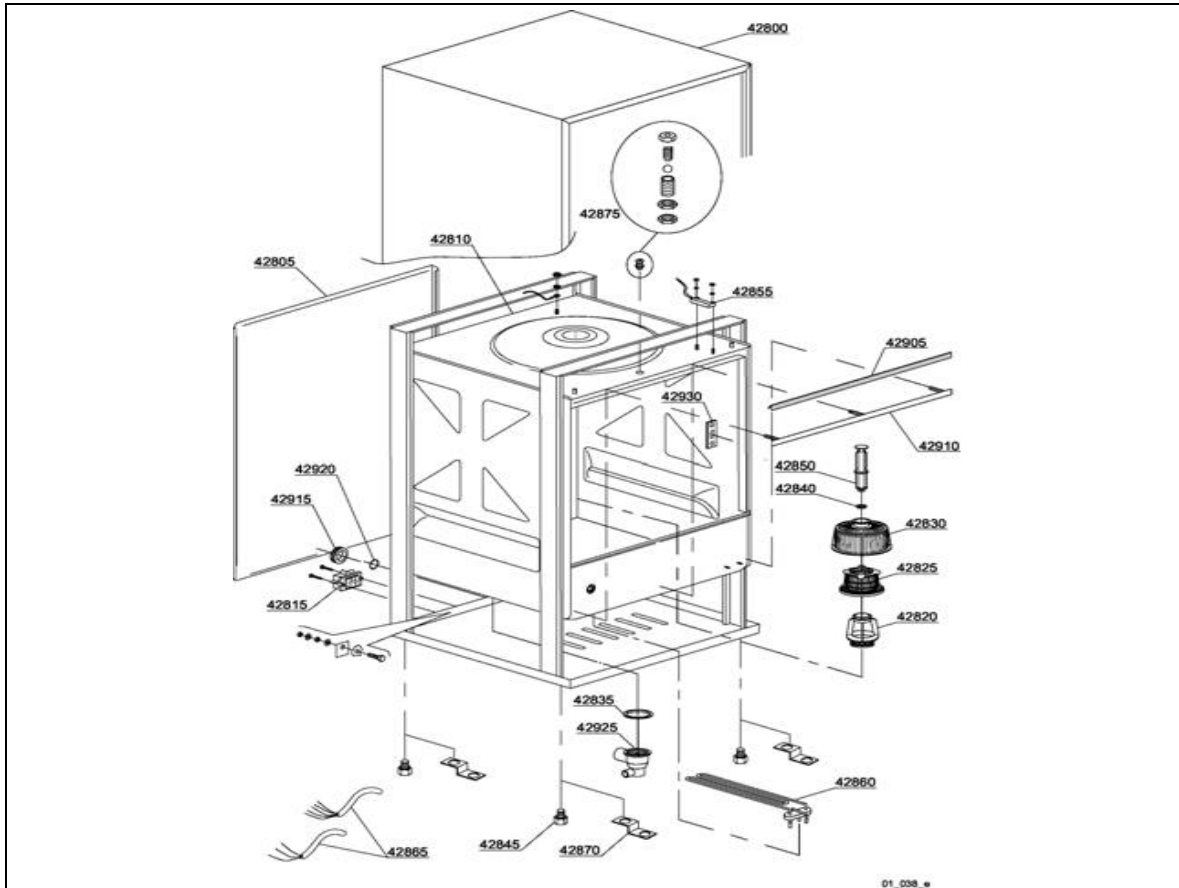

ID	P/N	DESCRIPTION
42800	2100.67	Cover
42805	2101.21	Back panel
42810	2101.22	Body
42815	2101.23	Cable-fastener with screw
42820	2100.71	Ferrule with filter
42825	2100.03	Internal filter with rack
42830	2100.07	Suction filter
42835	2101.07	95x75x3 O-ring minimum 2 pieces
42840	2100.57	DEM 40 O-ring minimum 2 pieces
42845	2100.62	High foot minimum 4 pieces
42850	2100.53	Overflow pipe

ID	P/N	DESCRIPTION
42855	2100.15	Reed magnet (UL)
42860	2100.66	2700W 220V 1 F6lx26 Heating element
42865	2101.24	5x2,5x2500 cable
42865	2101.25	3x4x2500 cable
42875	2101.05	Door jack assembly
42905	2101.26	Door O-ring
42910	2101.27	Door O-ring angular
42915	2101.28	D.40mm unloading pipe pass min 2pcs
42920	2101.29	D.13mm dosing pipe pass min 2pcs
42925	2100.70	Right side scrap tray
42930	2100.80	Door rod slide (minimum 4 pieces)

1.1.2. Lockup System

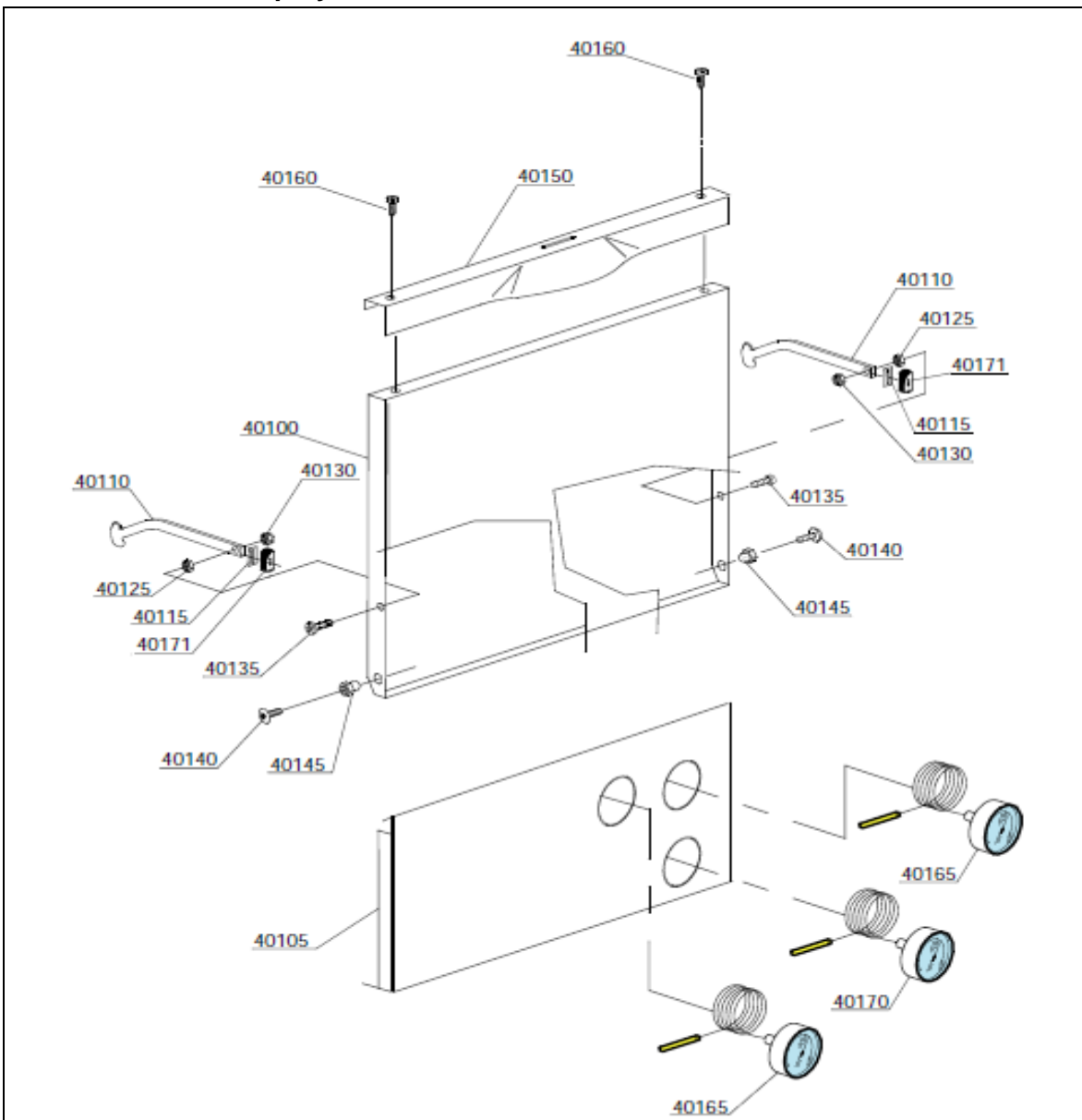

ID	P/N	DESCRIPTION
40100	2101.06	Door
40105	2101.30	Lower door
40110	2100.86	Right/left door rod
40115	2100.81	Hinge door seal
40120	2101.31	M4x8 screw minimum 20 pieces
40125	2100.82	M6 stainless steel nut min 20 pieces
40130	2100.83	M6 self-locking nut min 10 pieces
40135	2100.84	M6x6 stainless steel screw min 10 pcs

ID	P/N	DESCRIPTION
40140	2101.32	M6x12 stainless steel screw
40145	2101.33	Bush
40150	2100.23	Stainless steel handle
40155	2101.34	M4 inox Plated nut
40160	2101.35	M4x4 screw
40165	2100.39	Thermometer - UL ARThERMO
40170	2100.27	Gauge - UL ARThERMO
40171	2100.76	Door rod absorber bumper

1.1.3. Control Panel

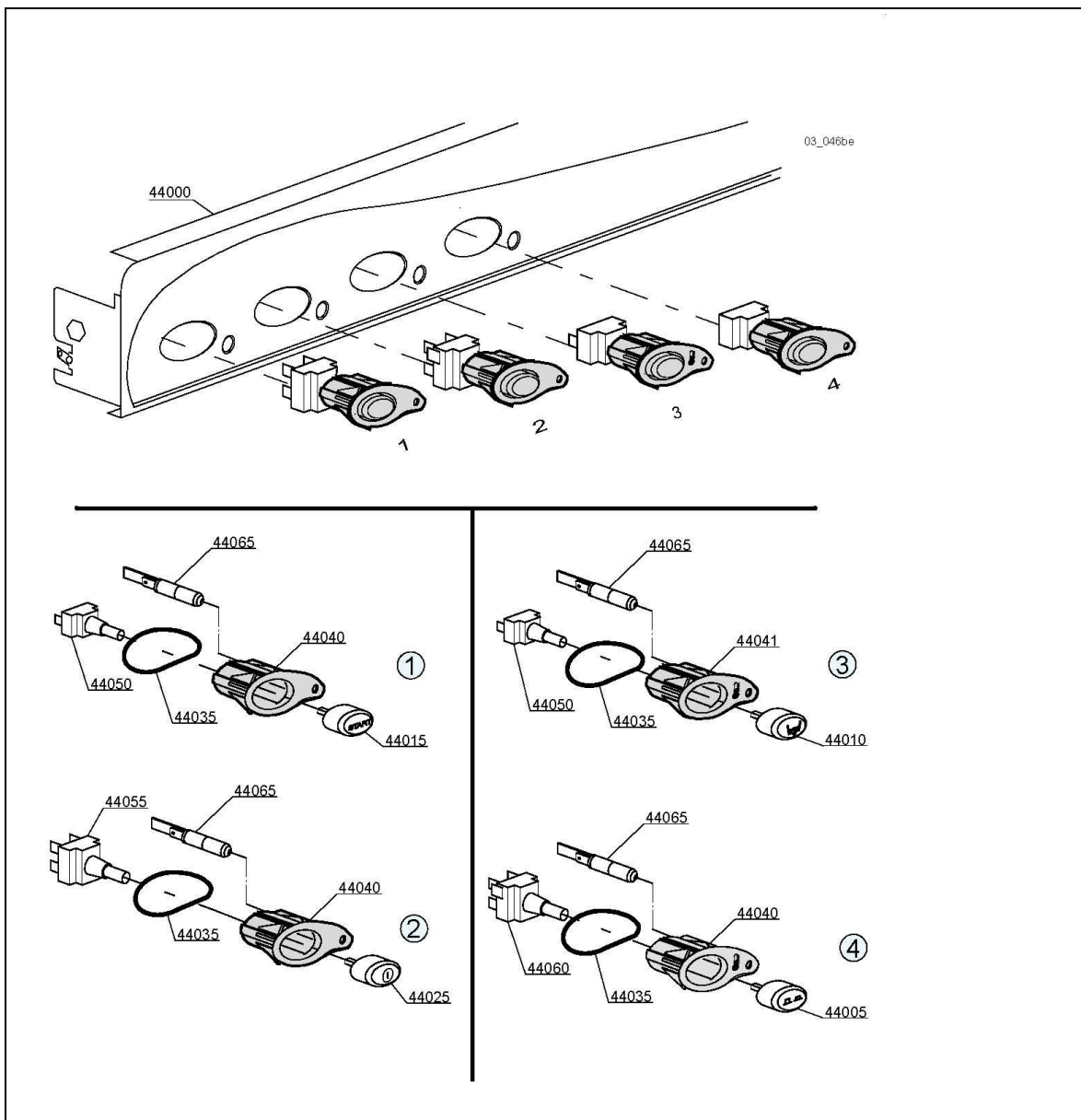

ID	P/N	DESCRIPTION
44000	2101.36	Control panel
44005	2100.94	Time selector switch push button
44010	2100.93	Drain pump push button
44015	2100.91	Start push button
44025	2100.92	ON-OFF push button
44035	2101.09	OR 2100 O-ring
44040	2101.37	Push button support

ID	P/N	DESCRIPTION
44041	2101.38	Temperature push button support
44050	2103.51	Start Switch 2 Pole Momentary
44060	2100.35	2Min/3Min Switch 4 Pole Maintained
44050	2101.39	Drain Switch 4 Pole Momentary
44055	2100.05	On/Off Switch 6 Pole Maintained
44060	2101.40	16A bipolar switch 6 Pole Momentary
44065	2100.47	Pilot light 220V

1.1.4. Control Components

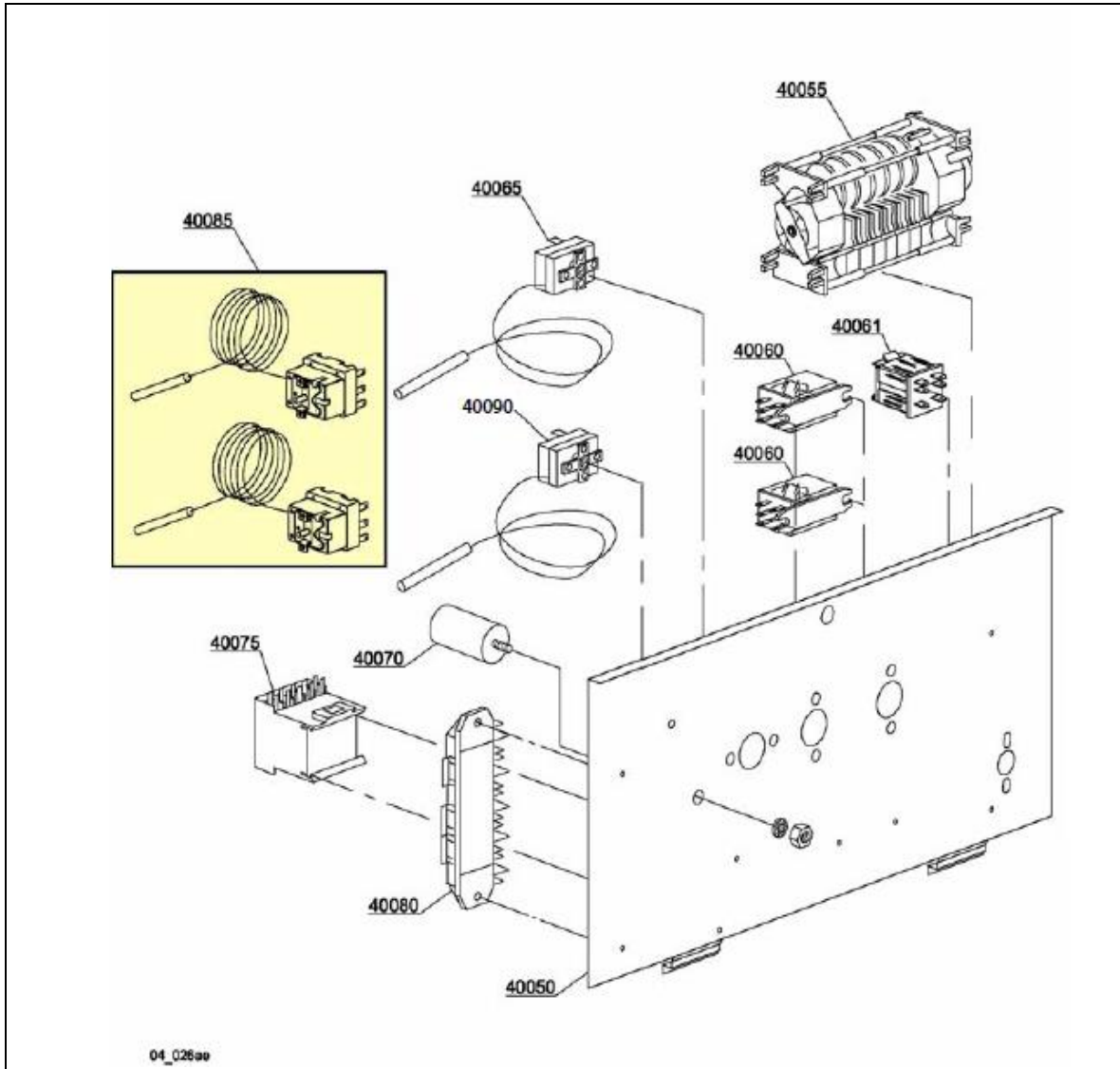

ID	P/N	DESCRIPTION
40050	2101.41	Electric component panel
40055	2100.21	120"/180" timer - 220Vac 60Hz
40060	2100.29	6 Pole Relay Heater & Start
40061	2100.33	8 Pole Relay Fill
40065	2100.25	0-90°C thermostat Booster

ID	P/N	DESCRIPTION
40075	2100.49	Contactor 230V 50/60Hz
40080	2100.51	6 poles wiring terminal
40085	2100.37	Hi Limit Wash Tank
40090	2100.22	0-90°C thermostat Wash Tank

1.1.5. Solenoid Valve Group

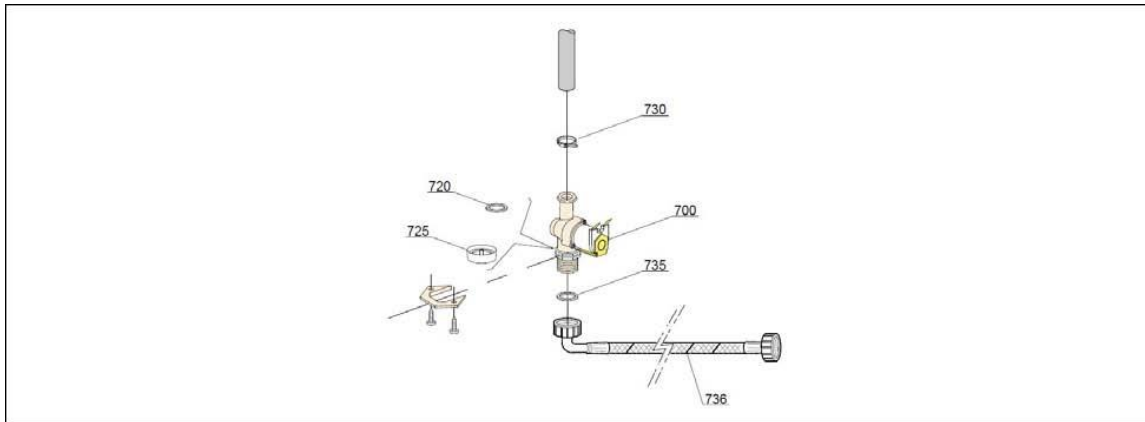

ID	P/N	DESCRIPTION
700	2100.13	Single solenoid valve - 230Vac
720	N.C.	Pressure reducing valve
730	2101.42	12/22 clamp (minimum 3 pieces)

ID	P/N	DESCRIPTION
735	2101.43	3/4 gasket
736	2100.64	Fill Hose

1.1.6. DVGW Assy. #02101.10

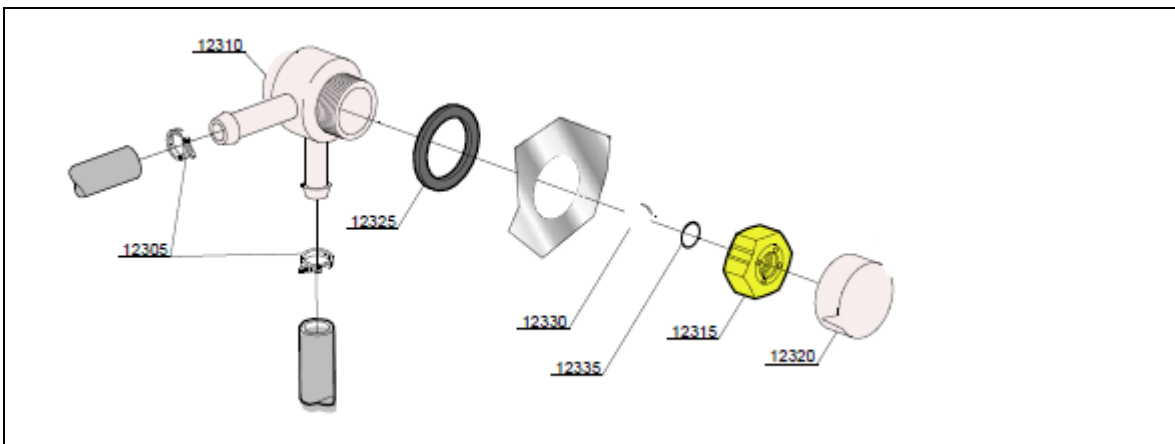

ID	P/N	DESCRIPTION
12305	2101.42	Clamp 12/22
12310	2102.35	Valve body center
12315	2102.32	Flat valve
12335	2102.33	O-ring 115 KTW

ID	P /N	DESCRIPTION
12320	2102.31	Flat valve cover
12325	2102.30	Valve gasket
12330	2102.34	Sphere

1.1.7. Rinse Aid Dispenser Group

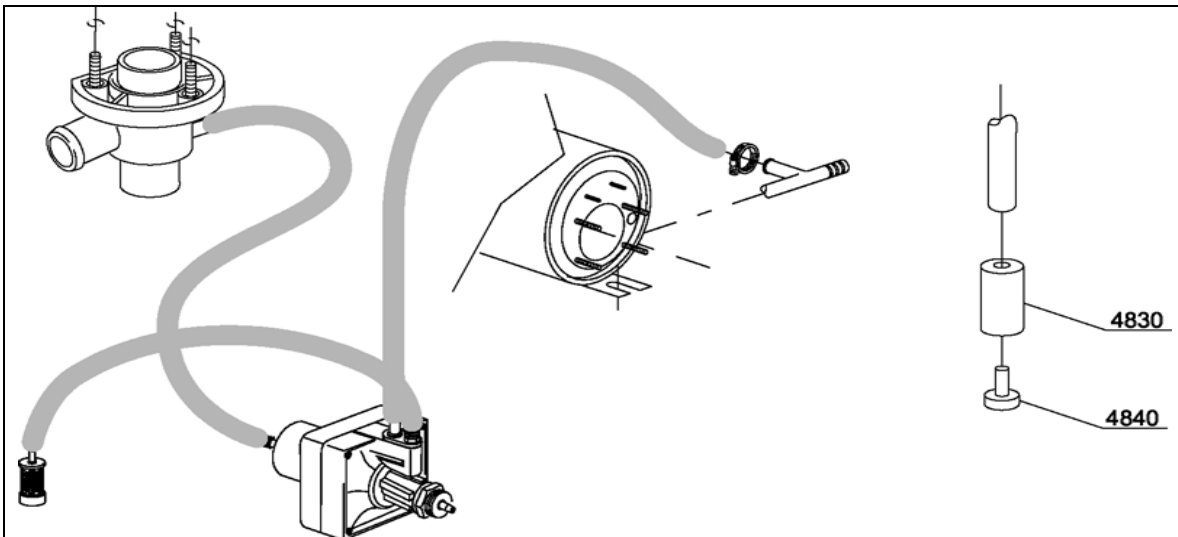
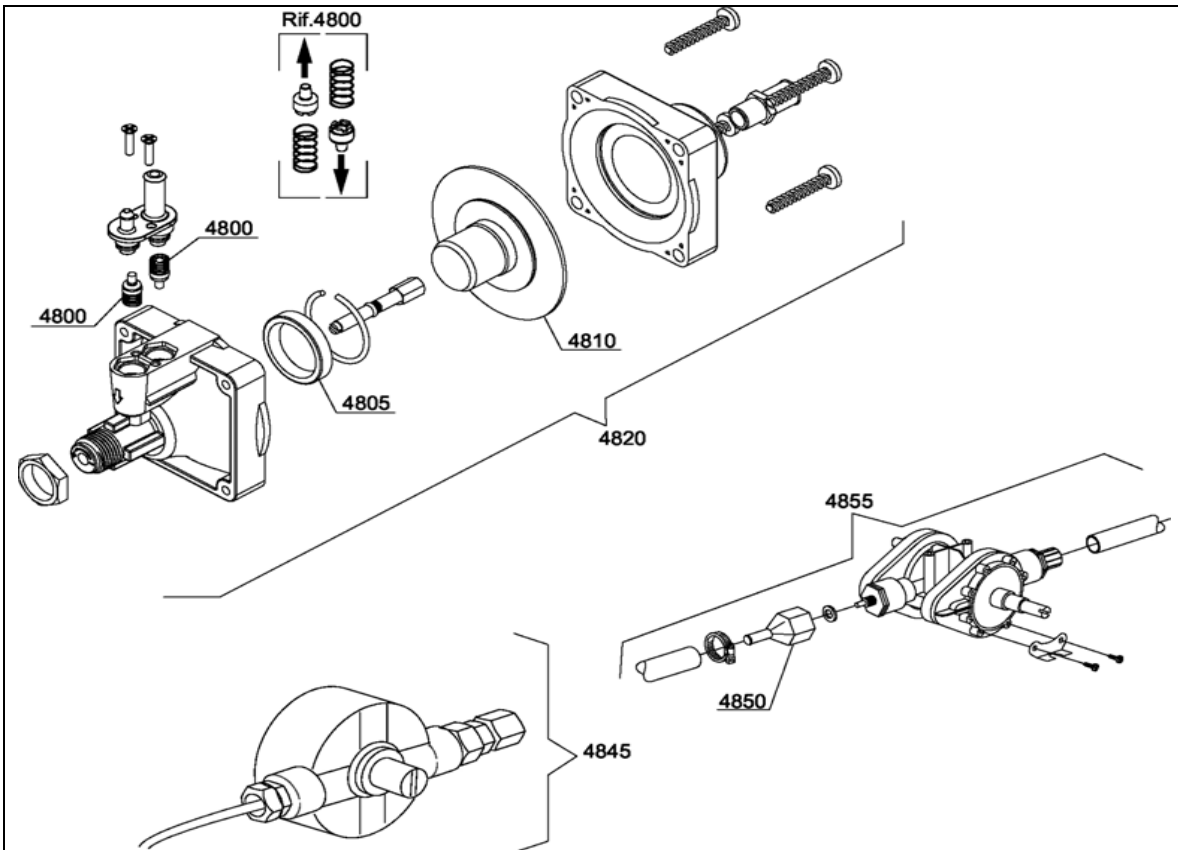

ID	P/N	DESCRIPTION
4800	2101.44	Tecnopro non return valve
4805	2104.45	D22 O-ring
4810	2101.46	Membrane

ID	P/N	DESCRIPTION
4820	2100.45	Tecnopro rinse aid dispenser
4830	2101.47	Ballast
4840	2101.48	Small filter minimum 3 pcs

1.1.8. Detergent Dispenser Group

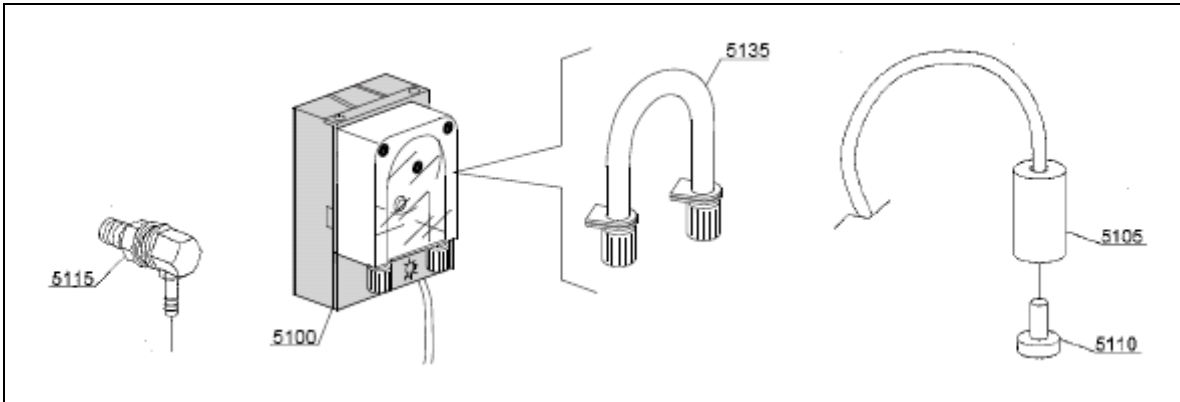

ID	P/N	DESCRIPTION
5100	2100.19	Seco detergent pump
5105	2101.47	Ballast
5110	2101.48	Small filter

ID	P/N	DESCRIPTION
5115	2101.02	Complete s/s injector
51135	2100.95	Seco thermoplastic pipe Squeeze Tube

1.1.9. Boiler Group

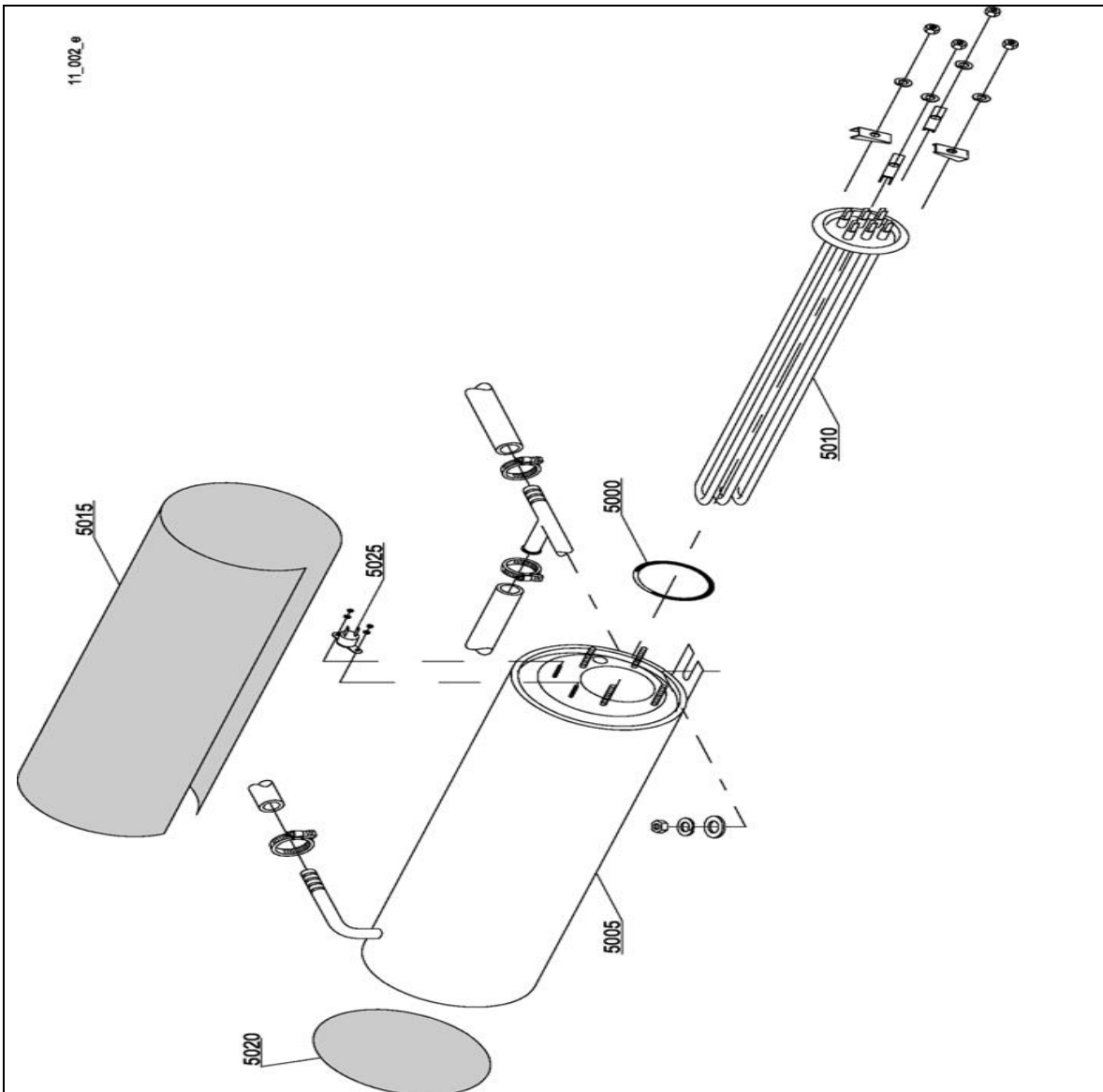

ID	P/N	DESCRIPTION
5000	2101.11	OR 151 NBR O-ring (minimum 5 pcs)
5005	2101.20	Boiler
5010	2100.01	6/6.53 KW 230/240V 3 heating element

ID	P/N	DESCRIPTION
5015	2101.49	Insulation boiler
5020	2101.51	D160 End piece (minimum 2 pieces)
5025	2101.52	Hi Limit Booster

1.1.10. 3 Ways Connection

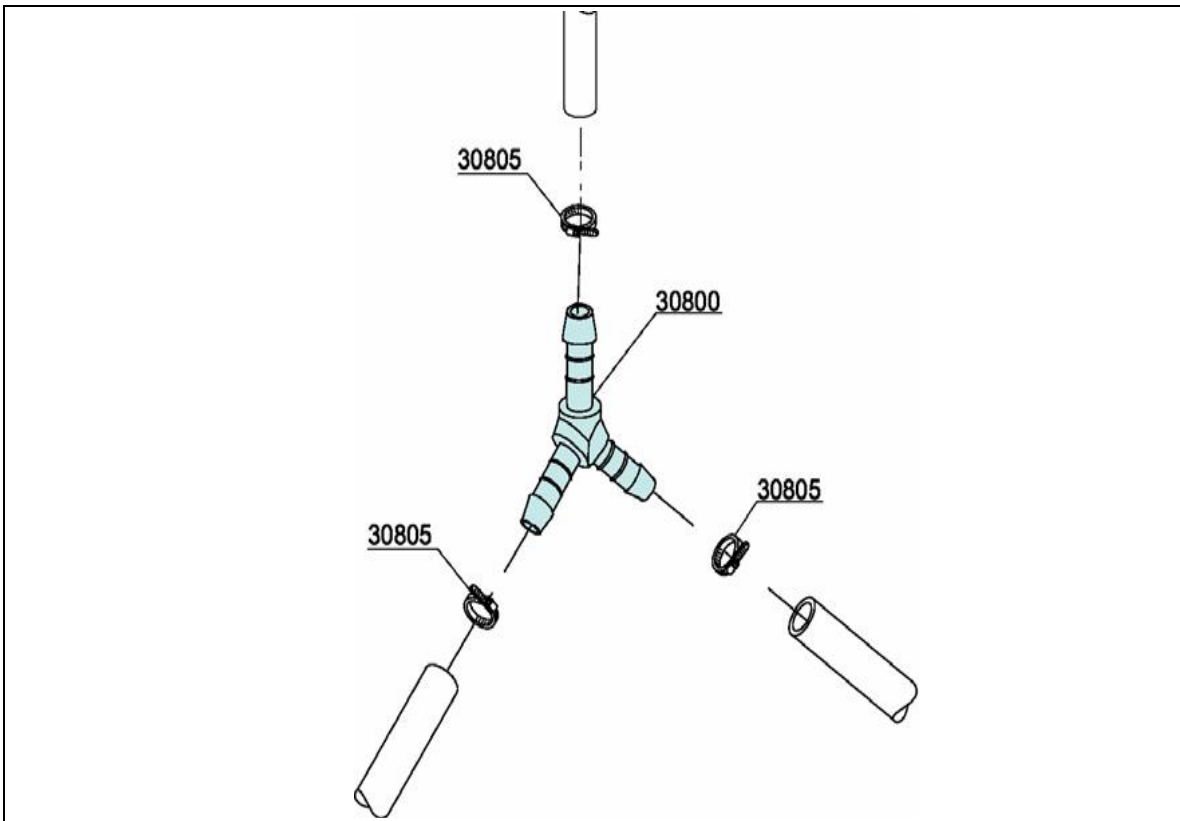

ID	P/N	DESCRIPTION
30800	2101.12	Plastic 3 -way connector. 012mm
30805	2101.42	12/22 clamp (minimum 3 pieces)

1.1.11. Wash Pump

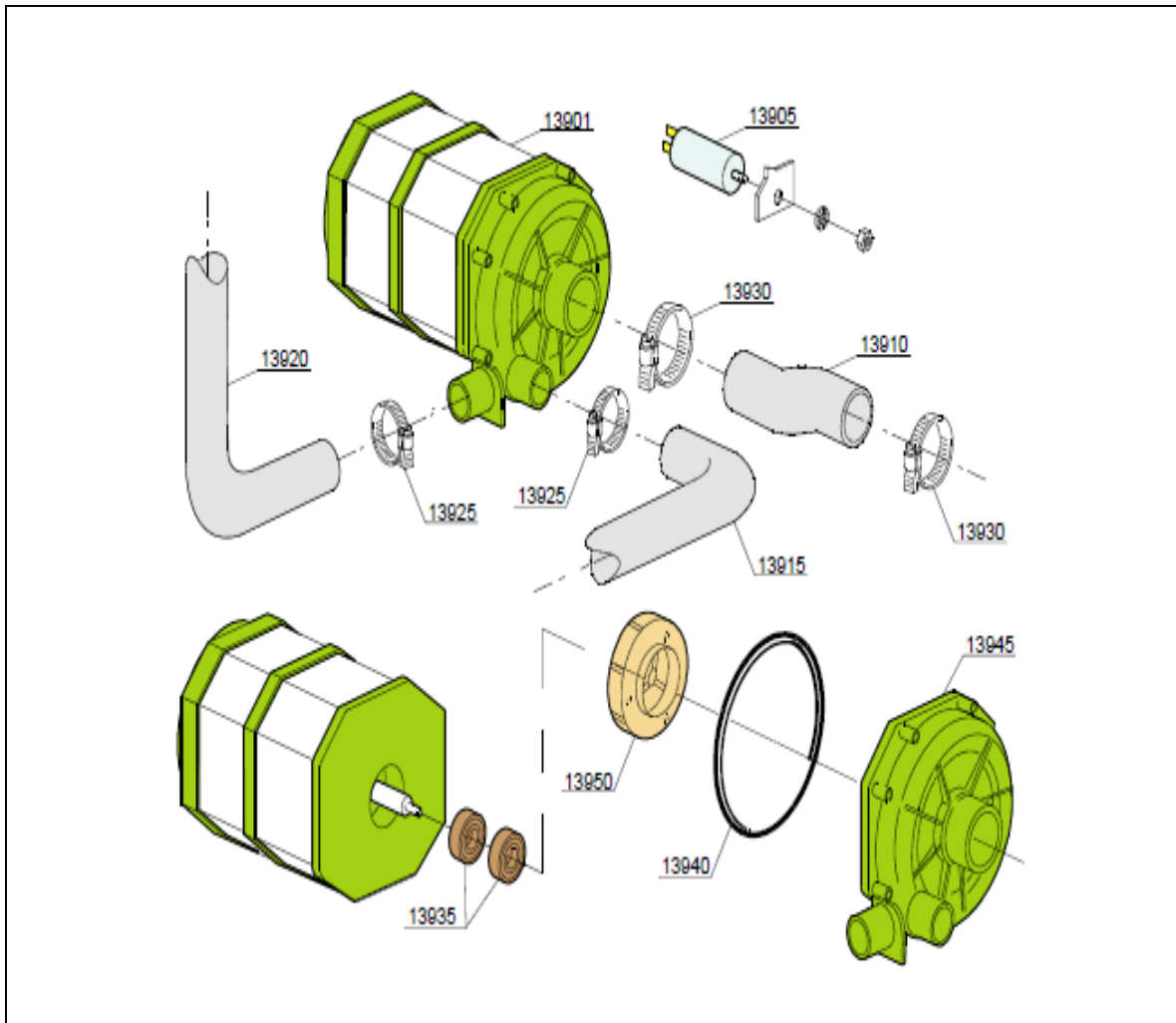

ID	P/N	DESCRIPTION
13900	2100.09	0,75 Hp Fir wash pump 220V/240V, 60Hz
13901	2101.53	0,70Hp Wash pump 230V, 60Hz
13905	2100.55	R12,5 uF condenser
13910	2101.13	Suction pipe coupling
13915	2101.14	Lower wash pipe coupling
13920	2101.15	Wash ramp

ID	P/N	DESCRIPTION
13925	2101.54	25/40 clamp (minimum 2 pieces)
13930	2101.55	30/45 clamp (minimum 2 pieces)
13935	2101.56	Rotating seals
13940	2101.57	OR pump O-ring (minimum 2 pcs)
13945	2101.58	Scroll
13950	2101.59	Pump rotor

1.1.12. Drain Pump Group

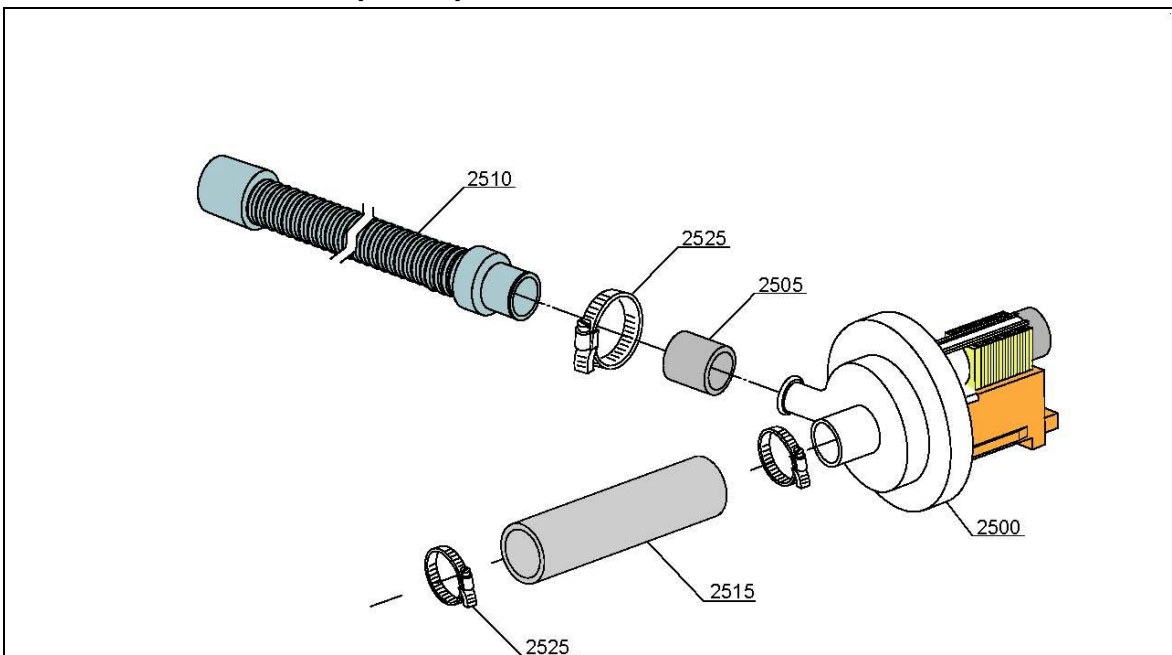

ID	P/N	DESCRIPTION
2500	2100.17	Drain pump 230V 60Hz (UL)
2505	2101.16	Pipe fitting (minimum 3 pieces)
2510	2100.60	Drain pipe

ID	P/N	DESCRIPTION
2515	2101.17	028 top wash pipe
2525	2101.54	25/40 clamp (minimum 2 pieces)

1.1.13. Pressure Switch Group

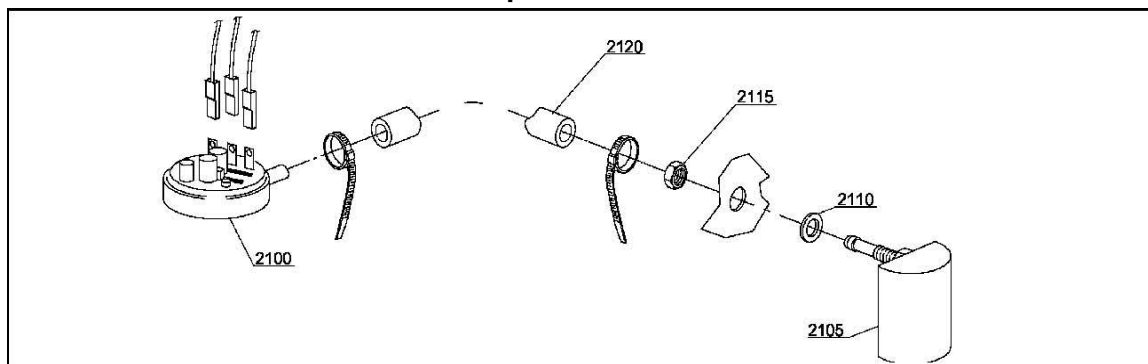

ID	P/N	DESCRIPTION
2100	2100.41	47-27 pressure switch
2105	2101.60	Grey air trap assembly
2110	2101.61	O-ring (minimum 10 pcs) D14x8x1,5

ID	P/N	DESCRIPTION
2115	2101.62	M8 stainless steel nut (minimum 10 pcs)
2120	2101.63	4,5X9 EPDM rubber hose (minimum 2mt)

1.1.14. Turret Group

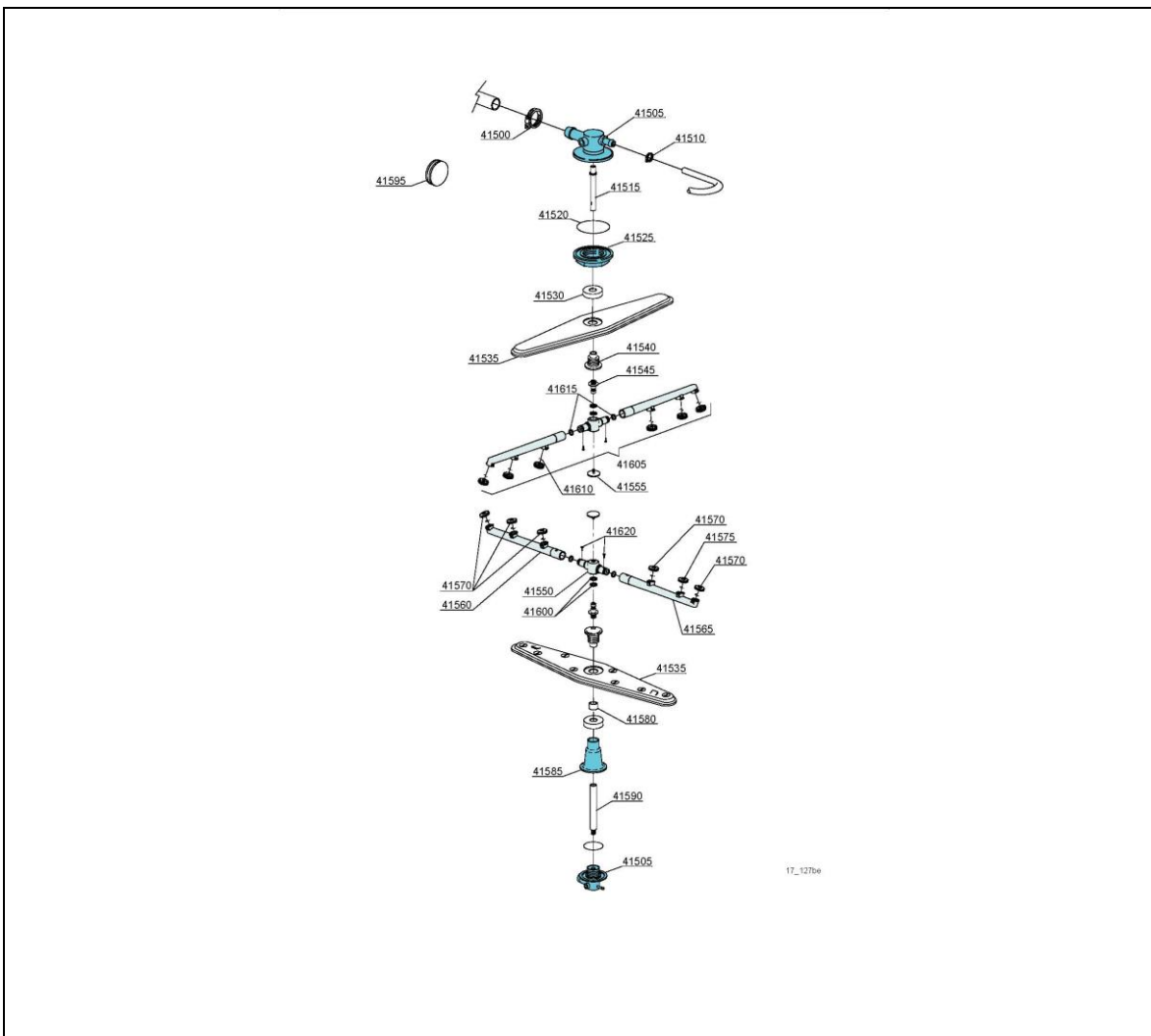

ID	P/N	DESCRIPTION
41500	2101.54	25/40 clamp (minimum 2 pieces)
41505	2100.73	Top/lower turret
41510	2101.42	12/22 clamp (minimum 3 pieces)
41515	2102.11	Upper rinse axle extension
41520	2100.85	6225 OR 160 NBR O-ring (min 5 pcs)
41525	2101.64	Ring nut for fixing turret
41530	2102.20	Nut for Wash Arm Bearing
41535	2101.04	Stainless steel wash rotor
41540	2102.05	Hub for rotor (inox rinse arm)
41545	2101.65	Rinse axle
41550	2102.12	Hub for rinse arm
41555	2101.67	Rinse arm screw
41560	2102.13	Right plastic rinse arm

ID	P/N	DESCRIPTION
41565	2102.14	Left plastic rinse arm
41570	2102.15	Open plastic rinse nozzle
41575	2102.16	Closed plastic rinse nozzle
41580	2101.70	Hub rotor/pipe coupling spacer
41585	2100.72	Lower pipe coupling
41590	2101.71	Rinse lower distributor connection axle
41595	2101.72	DVGW hole O-ring
41600	2102.17	O-ring for hub (rinse arm)
41605	2102.10	Top/lower rinse arm complete
41610	2102.18	OR R6 NBR O-ring
41615	2102.18	OR R6 NBR O-ring
41620	2102.19	4x10 TCB 8 spax toothed screw

1.1.15. Water Tempering Kit (Optional)

UC50e/UC60e Water Tempering Valve Kit

P/N 13470.65

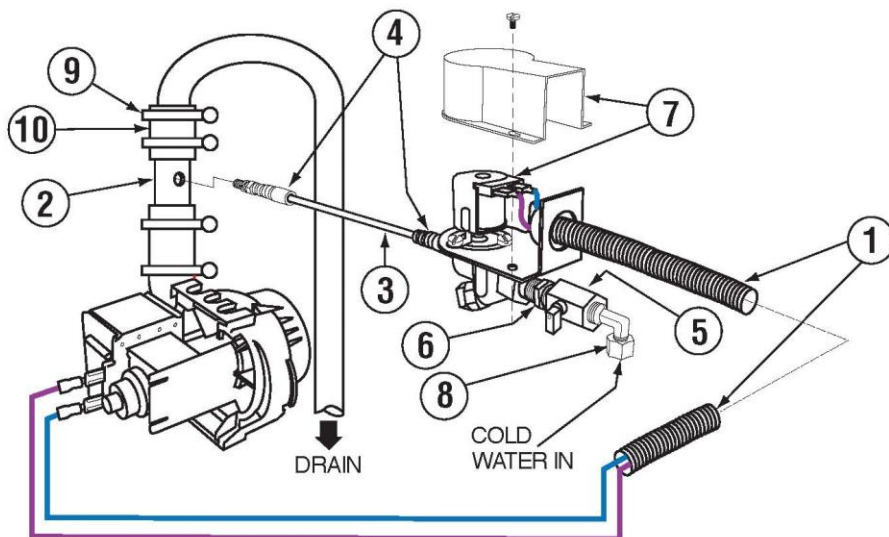

INSTALLATION INSTRUCTIONS TO DRAIN TEMPERING KIT

NOTE: Turn the dishwasher's wall breaker to "OFF" position before this installation.

1. Undo the drain hose clamp connecting drain hose leading to floor drain.
2. Install the water junction tee, as shown on drain line, and tighten clamp.
3. Connect the drain hose to upper port of water injection tee and tighten hose clamp.
4. Insert the provided white chemical tube into compression nut of water injection tee and tighten compression nut.
5. Connect the provided cold-water solenoid's power leads to the drain solenoid.
6. Connect the water injection assembly's ball valve to a cold water supply.
7. Run the dishwasher through a few cycles and make sure the cold water is injected and check for any possible leaks.

ITEM NO.	P/N	NO REQ'D	DESCRIPTION
1.	15400.17	2.5	3/8" SLIT RIBBED TUBING
2.	15603.50	1	GOOSE NECK PIPE ADAPTER TEE
3.	00425.54	2	CHEMICAL TUBING WHITE
4.	03415.50	2	FLEX-TIGHT FITTING
5.	41014.49	1	3/8" BALL VALVE
6.	40015.00	2	3/8"X1/4" HEX BUSHING
7.	41015.05	1	SOLENOID VALVE 1/4" W/COVER 220V
8.	40112.00	1	1/4" COMP X 1/4" MIP ELL
9.	03101.00	2	HOSE CLAMP #16 1"
10.	03108.60	.25	TRANSFER HOSE 1" REINFORCED

12-2012