

# ***SPRINT!***

## **Simple Laundry Dispenser**

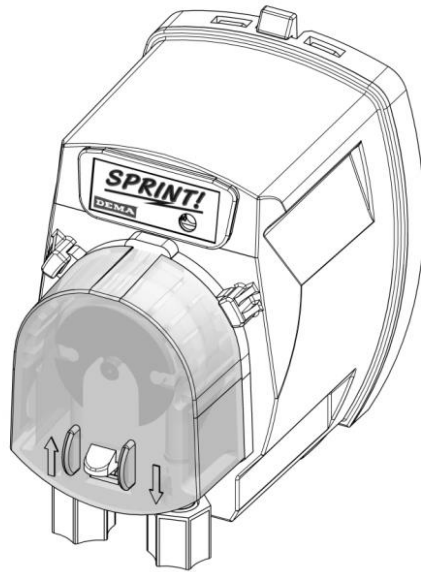

### **Overview**

---

Affordable and easy to use best describe the DEMA Sprint. The system is extremely simple to setup and program. The Sprint is suitable to deliver chemical product to small low volume laundry machines. The Sprint is the perfect single product laundry dispenser.

### **Warnings**

---



Installation of DEMA products must meet all applicable electrical codes and regulations established by national, city, county, parish, provincial or other agencies. It is possible that electrical codes and regulations require that a certified electrical contractor or engineer perform the electrical installation. For questions, contact a certified electrician.



**ALL ELECTRICAL POWER MUST BE TURNED OFF TO THE DISPENSER AND TO THE APPLIED MACHINE.**



All installations must conform to local plumbing codes and use approved backflow prevention devices. A pressure indicating tee is to be installed with existing faucets according to local plumbing codes in the state of Wisconsin and any other state that requires the use of a pressure indicating tee.



**ALWAYS WEAR PROTECTIVE CLOTHING AND EYEWEAR WHEN WORKING WITH CHEMICAL PRODUCTS.**

# Nomenclature & Specifications

## SPRINT.EJ

- └─ Pump Connections
  - J – ¼” Compression Nut (for ¼” OD LDPE or Vinyl tubing)
  - C – Cone Compression Nut (for ¼” OD x 1/16 wall soft tubing)
- └─ Squeeze Tube Material (pump tube)
  - E – EPDM
  - S – Silicone
  - P – Supertube (PVC)

### Pump Performance

100 ml/min (3.5 oz. /min)  
40 PSI MAX

### Dimensions & Weight

2.85lbs (1.3Kg) – Shipping weight

### Electrical Specifications

Main Power: 24/115/230VAC  
50/60Hz 0.5A

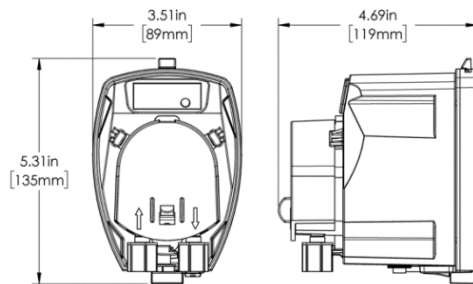

### Tools and Personal Protective Equipment (PPE) Required

1. Drill w/ drill bits and screwdriver bits
2. Precision Screwdrivers
3. Safety Glasses – (PPE)
4. Gloves – (PPE)

### ELECTRICAL INSTALLATION:

*All installations must be in accordance with city, county, parish, state, or provincial electrical codes and be performed by a certified electrician. For questions, please contact a local licensed electrical contractor.*

1. All electrical power must be turned off to the laundry machine and any other circuit that is to be used for this installation. Lockout and tag procedures must be observed when installing this device. Never open the Sprint enclosure while power is applied. Signals may be active from the laundry machine, even with Sprint power turned off. Use appropriately rated insulated wiring, electrical fixtures, and other materials that meet all applicable electrical and building codes.
2. **Sprint Controls Only:** This control has a switch to select the proper line voltage. Remove the back cover of the enclosure; use the switch to select between 230/115/24VAC as shown in Figure 1. Reinstall the back cover.

**WARNING:** This must be done *before* connecting power to the unit.

3. Connect to the appropriate power source.

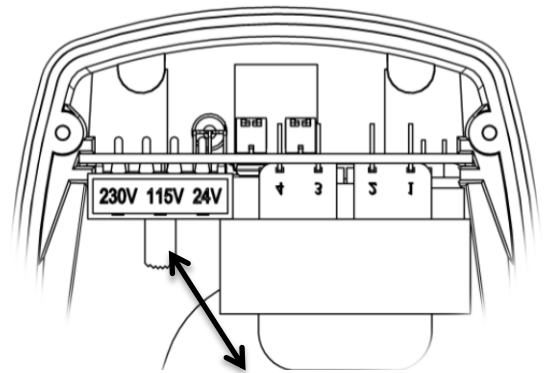
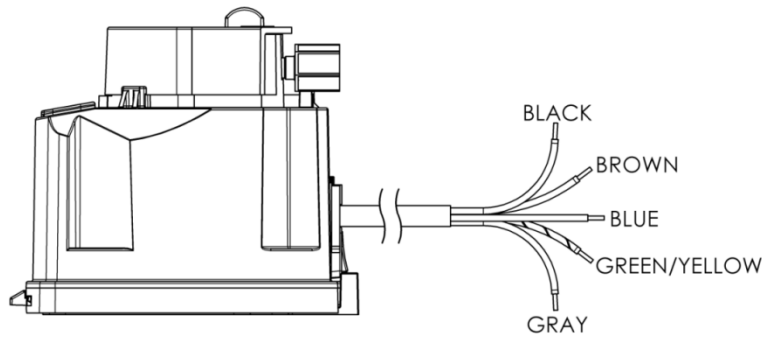

Figure 1. Input Voltage Switch



Wiring Color Code	
Brown Wire	Line
Blue Wire	Common
Green/Yellow Wire	Ground
Black and Gray	Incoming Signal (Trigger)

## **Setup and Programming**

1. Turn on the power switch; verify the LED turns on solid GREEN.
2. Remove the front cover nameplate to access the programming potentiometers. (Use a small precision screwdriver for this action.)
3. Programming the unit is done by setting the potentiometer to the desired time for both the Run Time and Lockout Time.
4. Set the Run Time potentiometer to a desired pump run time, range 10 ~ 120 seconds.
5. Set the Lockout potentiometer to a desired pump lockout time, discrete time as indicated on the label.
6. Apply trigger signal (24/115/230 VAC), the LED should flash RED as the trigger is active.
7. After a 5 second trigger, the pump will run for the Run Time set in Step 4; the LED should turn solid RED.
8. After the Run Time, the pump will stop and the unit will go into the Lockout Time set in Step 5; the LED should flash GREEN.
9. After the Lockout Time, the pump should be idle and the LED should turn solid GREEN.
10. The trigger signal will need to be OFF for at least 30 seconds after the pump Lockout Time, before starting the trigger.

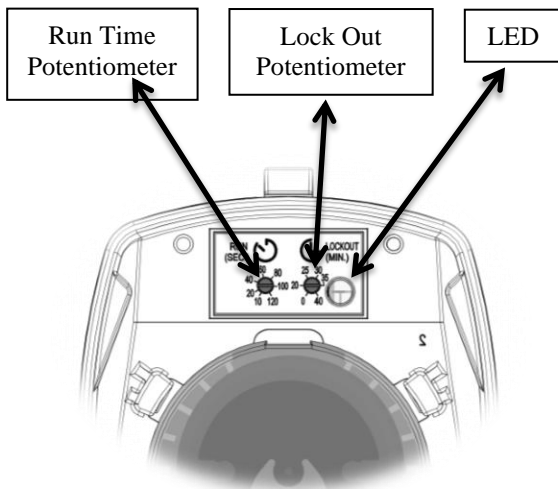

LED Colors and Functions	
Solid Red	Run Time
Flashing Red	Active Trigger Signal
Solid Green	Power Up / Idle
Flashing Green	Lockout Time

## Pump Priming

Press and hold the Prime button when the pump is in an idle state (Solid Green LED). The priming button is on the bottom of the unit next to the power switch. The pump will run while the button is depressed and stop running when the Prime button is released.

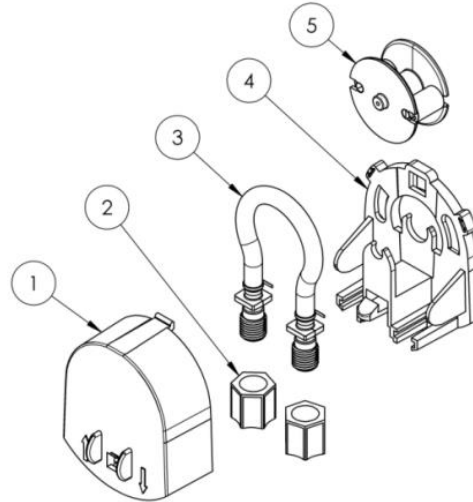
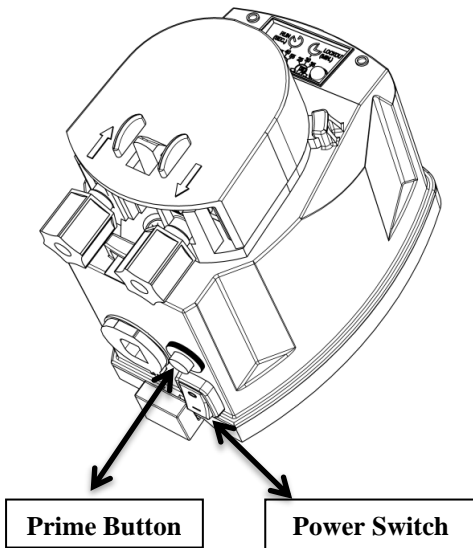

<b>Pump Replacement Parts</b>			
<b>Item</b>	<b>DEMA® P/N</b>	<b>Qty</b>	<b>Description</b>
1	81-240-2	1	Pump Bore
2	80-67-13	1	Compression Fittings
3	81-231-1	1	Squeeze Tube Assembly
4	81-241-2	1	Pump Base
5	81-219-1	2	Roller Block Assembly

## Warranty

### Merchandise Returns

*No Merchandise will be Returned for Credit Without DEMA'S Written Permission. Returned Merchandise Authorization Number is Required in Advance of Return.*

### Product Warranty

DEMA products are warranted against defective material and workmanship under normal use and service for one year from the date of manufacture. This limited warranty does not apply to any products that have a normal life shorter than one year or failure and damage caused by chemicals, corrosion, physical abuse, or misapplication. Rubber and synthetic rubber parts such as "O"-rings, diaphragms, PVC tubing, and gaskets are considered expendable and are not covered under warranty. This warranty is extended only to the original buyer of DEMA products. If products are altered or repaired without prior approval of DEMA, this warranty is void.

Defective units or parts should be returned to the factory with transportation prepaid. If inspection shows them to be defective, they will be repaired or replaced without charge, F.O.B. factory. DEMA assumes no liability for damages. Return merchandise authorization number must be granted in advance of returned units for repair or replacement (See "Merchandise Returns" above).