

# PX

## Ware Wash Chemical Dispensing System

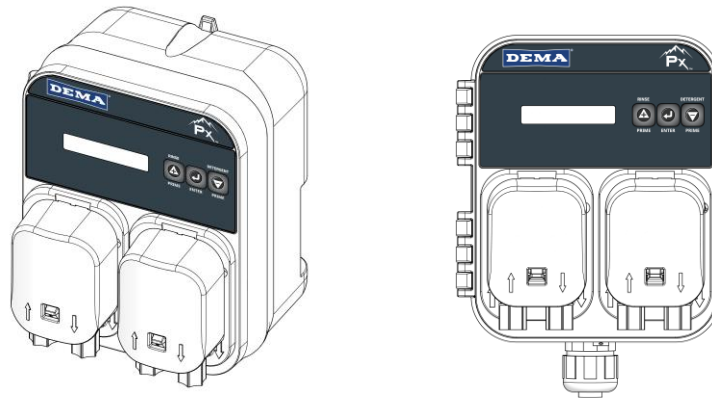

### Overview

The PX ware wash chemical dispenser is economical but with essential functions. Digital programming provides an intuitive experience when setting up the dispenser in application. The system uses a probeless feature to control detergent concentration. Additionally, the system can be configured for liquid or dry detergent. It also features a rinse that has typical programming features including speed control.

### Warnings



Installation of DEMA products must meet all applicable electrical codes and regulations established by national, city, county, parish, provincial or other agencies. It is possible that electrical codes and regulations require that a certified electrical contractor or engineer perform the electrical installation. For questions, contact a certified electrician.



**PRIOR TO INSTALLATION OR SERVICE, ALL ELECTRICAL POWER MUST BE TURNED OFF TO THE DISPENSER AND TO THE APPLIED MACHINE.**



**ALWAYS WEAR PROTECTIVE CLOTHING AND EYEWEAR WHEN WORKING WITH CHEMICAL PRODUCTS.**

### Specifications

For Indoor Use Only		
<b>Main Power</b>	115 VAC – 230 VAC	50/60 Hz 1.0 A
<b>Trigger Signals</b>	24V – 240V	50/60 Hz
<b>Motors/Solenoid Valves</b>	24VDC	
<b>Case Material</b>	ABS	
<b>Maximum Altitude</b>	2000 M	6500 ft
<b>Environmental Temperature</b>	0-40°C	32-104°F
<b>Installation Category</b>	II	
<b>Pollution Category</b>	II	
<b>UL Recognized</b>	U.S.A. and Canada	



## Overall Size

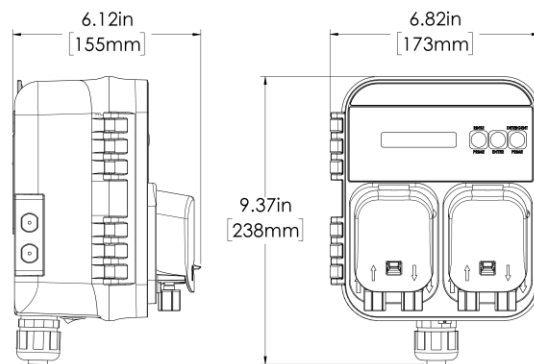

## Installation

### Dish Room Survey

Determine the best location to mount the PX on the wall within 10ft (3M) of the dish machine.

- Main power electrical cable is 12ft (3.6M) long.
- Optional temperature sensor cables are 15ft (4.5M) long.
- Locate unit away from direct water spray and excessive steam.

### Opening the PX door

1. Remove the detergent pump cover or detergent valve cover.
2. Use a #2 phillips screwdriver to loosen the retaining screw.
3. Door will open when loosened.

### Mounting the PX

2. Remove the Mounting Bracket from the dispenser.
3. Mount the bracket on the wall using the included mounting screws and anchors.
  - a) The integrated bubble level can be used to assure the dispenser is level.
4. Slide the dispenser onto the bracket so that the snap lever will latch at the top of the dispenser.
  - a) Optionally, a screw can be installed to secure the dispenser to the mounting bracket.

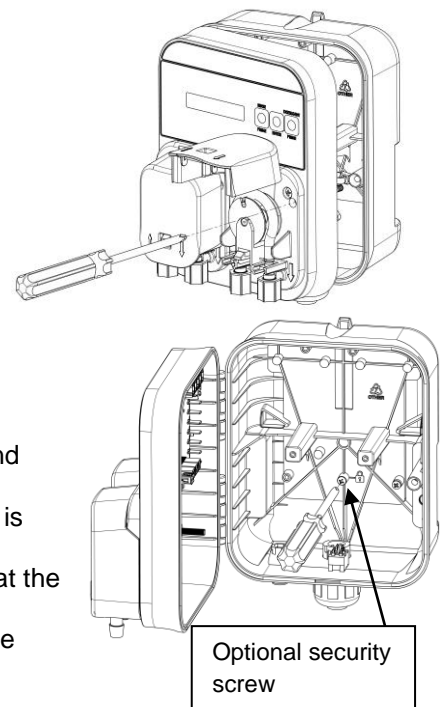

**WARNING: For safety purposes disconnect main power to the dish machine. Connect power to the Pinnacle per the dish machine manufacturer's recommendations. Electrical codes may require a certified electrician for proper installation. UNIT MUST BE GROUNDED (EARTHED).**

### Electrical Wiring Connection

1. The PX comes with a prewired cable for main power, earth ground and trigger signals. Use the color code table below to identify the different wires.
  - a) Main power should be wired so that anytime the dish machine is powered, the PX is receiving constant power.
  - b) Locate appropriate trigger wire connection points on the dish machine for wash and rinse trigger signals.
  - c) Ground wire must be connected to a solid earth ground on the machine.

The PX can be wired to 120VAC or 240VAC. There is a switch on the main control board that must be set to the correct voltage. The PX comes set at 240VAC from the factory.

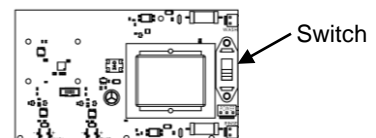

### **Main Power and Trigger Cable Color Code**

**Main Power** - Brown and Blue Wires to the idle power or constant power terminals on the machine. (100VAC to 250VAC only)

**Rinse Trigger** - Red and Black wires to the rinse trigger terminals on the machine 24-240VAC

**Wash/Detergent Trigger** - White and Orange wires to the detergent trigger terminals to the machine 24-240VAC

**Ground** – Green wire to Earth Ground on the machine

### **Chemical Pump and Tubing Connections**

1. Install the detergent bulkhead fitting at the wash tank.
  - a. Must be above the water line
  - b. Uses a 7/8" hole for the bulkhead mount
2. Install the rinse check valve to the rinse manifold.
  - a. Check valve uses 1/8" NPT for installation to the rinse manifold or the rinse temperature probe adapter fitting.
3. Install the 1/4" push-on fittings at the pump inlet and outlet.
4. For each chemical, install the 1/4" chemical line into the tube stiffener and place into the chemical container.
5. Route the chemical line to the inlet of the pump and install into the push-on fitting.
6. Install the 1/4" chemical line to push-on fitting at the pump outlet and route to the respective fitting at the dish machine.
  - a. Bulkhead fitting at wash tank for detergent
  - b. Rinse check valve at the rinse manifold

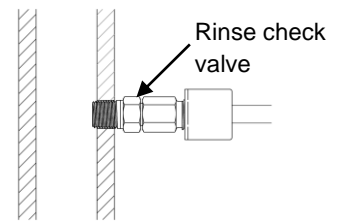
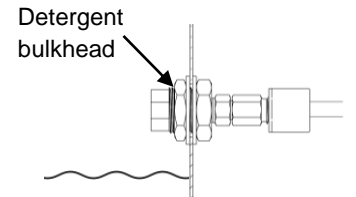

### **Pump Priming**

1. PX has three buttons on the front. The two outer buttons are pump prime when the PX is on the idle screen.
  - a. Left button is rinse prime
  - b. Right button is detergent prime
2. Press and hold each button to start the pump. Once pump is running release the button.
3. Press the button again to stop the pump.

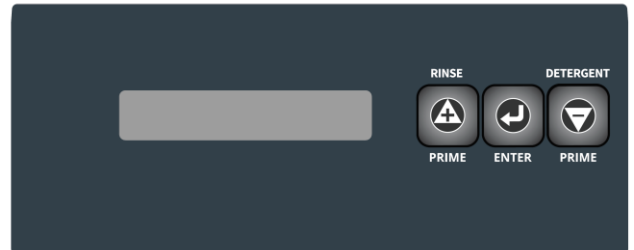

### **Accessing Programming and Setup**

1. With PX showing the idle screen, press and hold the ENTER button to access programming.
2. See programming reference guide I1407 for all programming features.

## Servicing – Replacement Parts – Optional Kits

### Pinnacle Wiring Diagram – Detergent or Valve and Rinse Pump

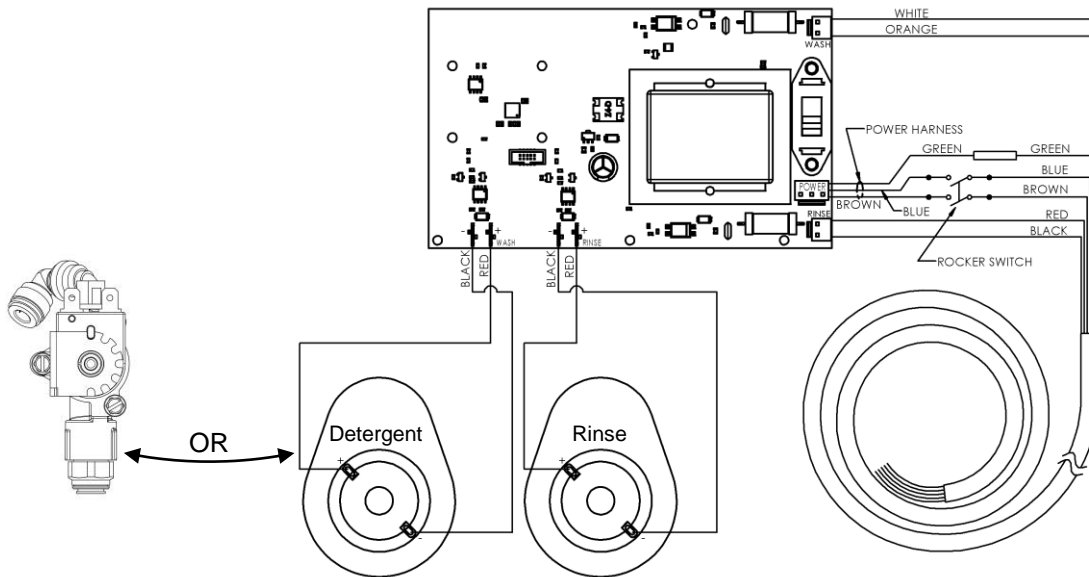

### PX Small Motor Detergent Pump Kit (82.60.26)

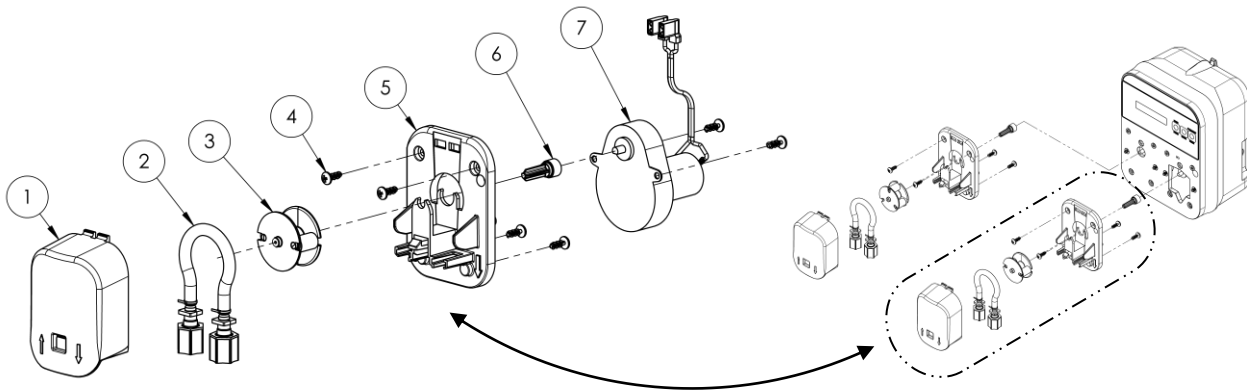

NO.	DEMA NO.	DESCRIPTION
1	41325.1	PUMP BORE SMALL COVER, RED
2	81.231.1	SQUEEZE TUBE
3	81.219.2	ROLLER BLOCK ASSY. (2 ROLLER)
4	44.116.1	#8-18 X 1/2" SS. HI-LOW PAN HEAD SCREW
5	41326.1	PUMP BASE - SMALL
6	81.220.1	DRIVE SHAFT ADAPTER
7	82.60.10	MOTOR ASSY. KIT SMALL W/ SCREWS - 118 RPM

**PX Small Motor Rinse Pump Kit (82.60.13)**

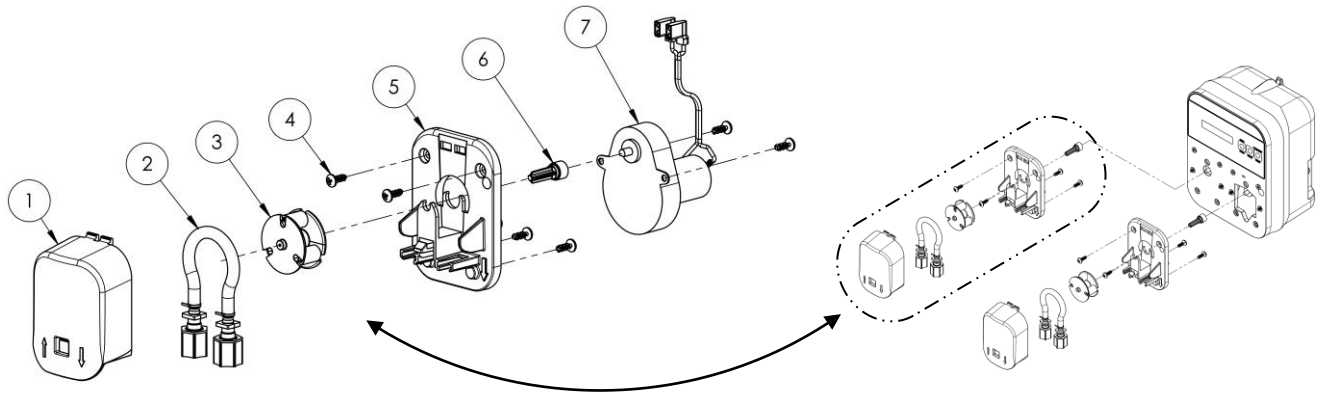

NO.	DEMA NO.	DESCRIPTION
1	41325.2	PUMP BORE SMALL COVER, BLUE
2	81.231.1	SQUEEZE TUBE
3	81.219.1	ROLLER BLOCK ASSY (3 ROLLER)
4	44.116.1	#8-18 X 1/2" SS. HI-LOW PAN HEAD SCREW
5	41326.1	PUMP BASE - SMALL
6	81.220.1	DRIVE SHAFT ADAPTER
7	82.60.11	MOTOR ASSY. KIT SMALL W/ SCREWS - 35 RPM

**PX Solenoid Valve Kit (82.60.14)**

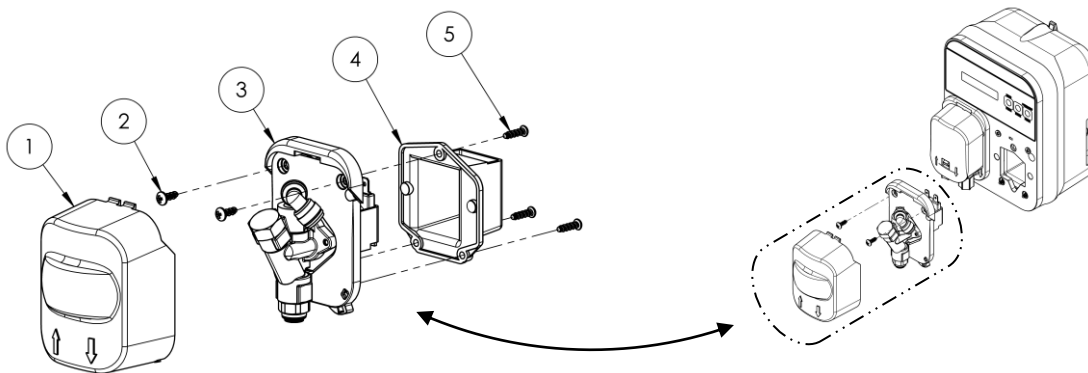

NO.	DEMA NO.	DESCRIPTION
1	41380.1	VALVE COVER, RED
2	44.116.1	#8-18 X 1/2" SS. HI-LOW PAN HEAD SCREW
3	X41331.1	VALVE & MOUNTING PLATE ASSY
4	41406.1	SOLENOID BACK COVER
5	44.116.6	#8-18 X 5/8" SS. HI-LOW PAN HEAD SCREW

## Electronics and Hardware

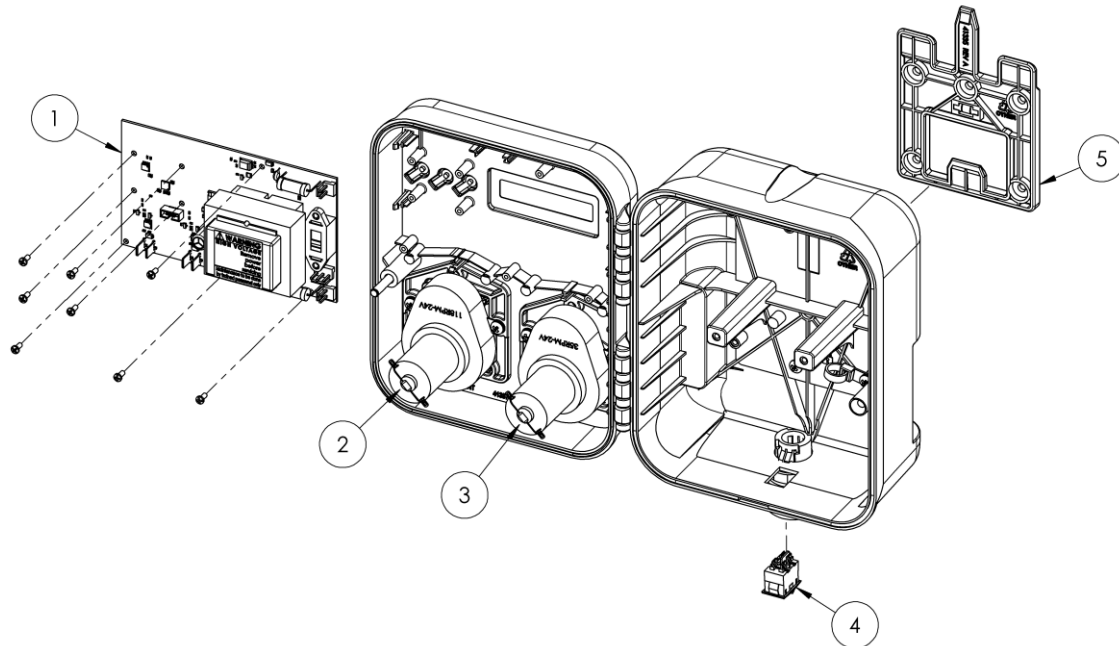

NO.	DEMA NO.	DESCRIPTION
1	82.60.20	CONTROL BOARD W/ MOUNTING SCREWS KIT
2	82.60.10	DETERGENT MOTOR SMALL W/ MOUNTING SCREWS
3	82.60.11	RINSE MOTOR SMALL WITH MOUNTING SCREWS
4	81.163.1	POWER SWITCH
5	82.60.19	WALL MOUNTING BRACKET W/ MOUNTING SCREWS KIT

## Warranty

### Merchandise Returns

No Merchandise will be Returned for Credit Without DEMA'S Written Permission. Returned Merchandise Authorization Number is Required in Advance of Return.

### Product Warranty

DEMA products are warranted against defective material and workmanship under normal use and service for one year from the date of manufacture. This limited warranty does not apply to any products that have a normal life shorter than one year or failure and damage caused by chemicals, corrosion, physical abuse, or misapplication. Rubber and synthetic rubber parts such as "O"-rings, diaphragms, PVC tubing, and gaskets are considered expendable and are not covered under warranty. This warranty is extended only to the original buyer of DEMA products. If products are altered or repaired without prior approval of DEMA, this warranty is void. Defective units or parts should be returned to the factory with transportation prepaid. If inspection shows them to be defective, they will be repaired or replaced without charge, F.O.B. factory. DEMA assumes no liability for damages. Return merchandise authorization number must be granted in advance of returned units for repair or replacement (See "Merchandise Returns" above).