

# Pinnacle Pro

## Ware Wash Chemical Dispensing Systems

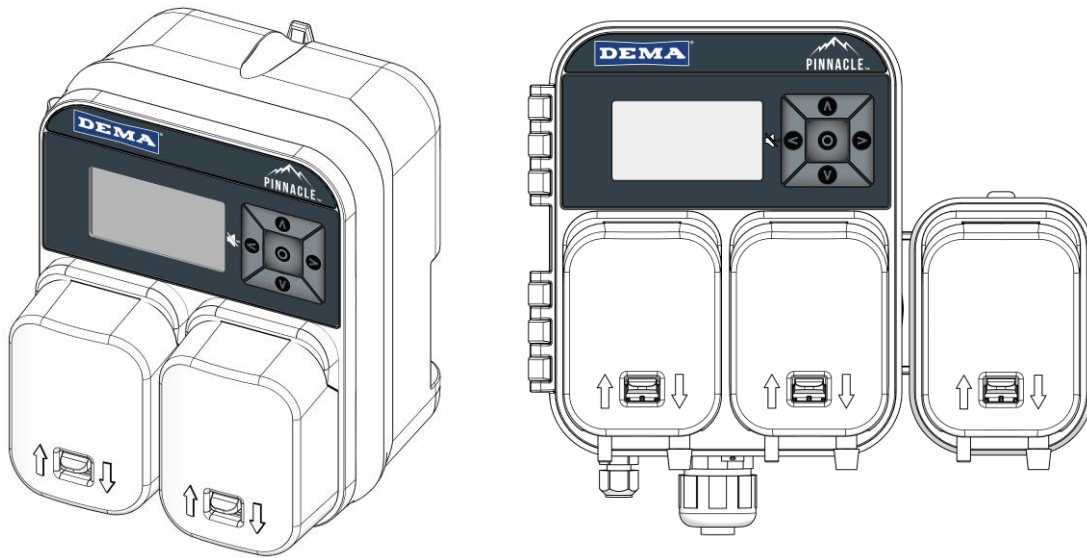

### Overview

The Pinnacle Pro ware wash chemical dispensing systems have been designed to work automatically with mechanical dish wash machines. The system includes advanced electronic controls that will ease installation and provide accurate and reliable operation. Features include concentration, probeless or Auto Switchover modes. It also supports liquid or dry chemicals along with a sanitizer pump option. The Pinnacle Pro uses high-capacity motors and pumps. The systems can be programmed on board or with a smart device using the DEMA Smarttech App.

### Warnings



Installation of DEMA products must meet all applicable electrical codes and regulations established by national, city, county, parish, provincial or other agencies. It is possible that electrical codes and regulations require that a certified electrical contractor or engineer perform the electrical installation. For questions, contact a certified electrician.



**PRIOR TO INSTALLATION OR SERVICE, ALL ELECTRICAL POWER MUST BE TURNED OFF TO THE DISPENSER AND TO THE APPLIED MACHINE.**



**ALWAYS WEAR PROTECTIVE CLOTHING AND EYEWEAR WHEN WORKING WITH CHEMICAL PRODUCTS.**

# Specifications

## Operational Requirements

For Indoor Use Only		
Main Power	100 – 250 VAC	50/60 Hz 1.0 A
Trigger Signals	24V – 480V	50/60 Hz
Motors/Solenoid Valves	24VDC	
Case Material	ABS	
Maximum Altitude	2000 M	6500 ft
Environmental Temperature	0-40°C	32-104°F
Installation Category	II	
Pollution Category	II	
UL Recognized	U.S.A and Canada	
CE Certified	IEC 60335-1	



## Overall Size

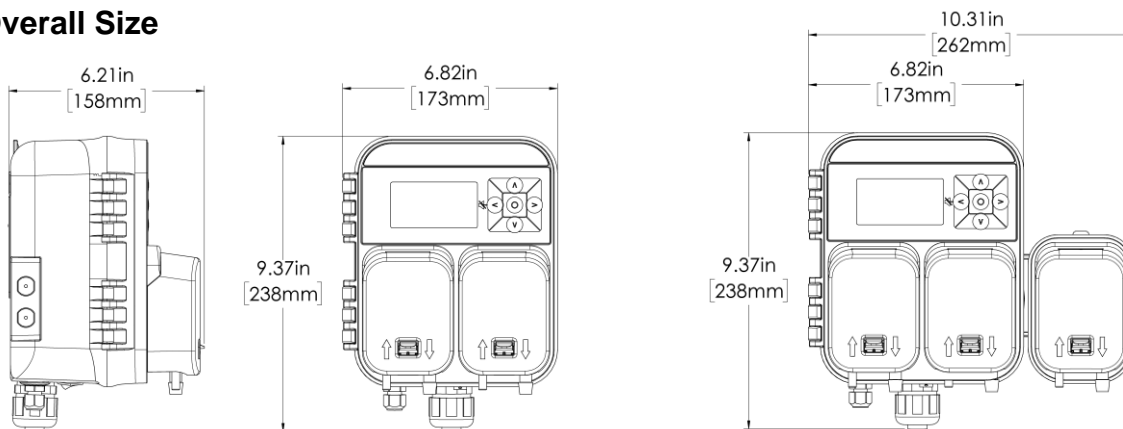

## Installation

### Dish Room Survey

Determine the best location to mount the Pinnacle Pro on the wall within 10ft (3M) of the dish machine.

- Main power electrical cable is 12ft (3.6M) long.
- Optional temperature sensor cables are 15ft (4.5M) long.
- Locate away from direct water spray and excessive steam.

### Opening the Pinnacle Pro door

1. Remove the detergent pump cover or detergent valve cover.
2. Use a #2 phillips screwdriver to loosen the retaining screw.
3. Door will open when loosened.

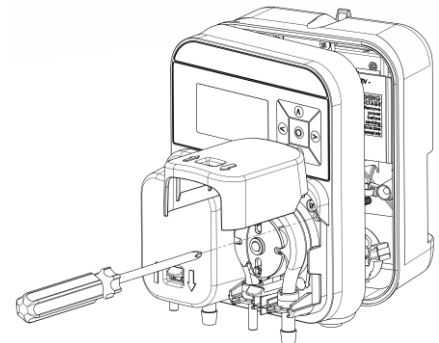

### Mounting the Pinnacle Pro

1. Remove the Mounting Bracket from the dispenser.
2. Mount the bracket on the wall using the included mounting screws and anchors.
  - a) The integrated bubble level can be used to assure the dispenser is level.
3. Slide the dispenser onto the bracket so that the snap lever will latch at the top of the dispenser.
  - a) Optionally, a screw can be installed to secure the dispenser to the mounting bracket.

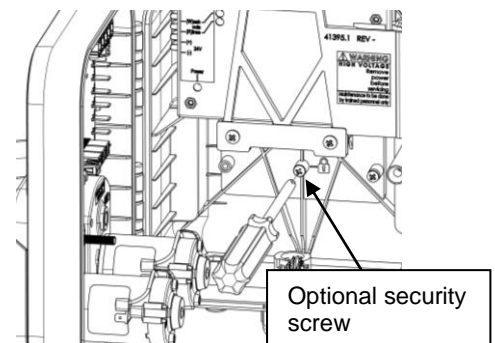



**WARNING: For safety purposes disconnect main power to the dish machine. Connect power to the Pinnacle per the dish machine manufacturer's recommendations. Electrical codes may require a certified electrician for proper installation. UNIT MUST BE GROUNDED (EARTHED).**

### Electrical Wiring Connection

1. The Pinnacle Pro comes with a prewired cable for main power, earth ground and trigger signals. Use the color code table below to identify the different wires.
  - a) Main power should be wired so that anytime the dish machine is powered, the Pinnacle Pro is receiving constant power.
  - b) Locate appropriate trigger wire connection points on the dish machine for wash and rinse trigger signals.
  - c) Ground wire must be connected to a solid earth ground on the machine.

#### **Main Power and Trigger Cable Color Code**

**Main Power** - Brown and Blue Wires to the idle power or constant power terminals on the machine. (100VAC to 250VAC only)

**Rinse Trigger** - Red and Black wires to the rinse trigger terminals on the machine 24-480VAC

**Wash/Detergent Trigger** - White and Orange wires to the detergent trigger terminals to the machine 24-480VAC

**Ground** - Green wire to Earth Ground on the machine

### Conductive Probe and Optional Wash Tank Temperature Sensor Installation

1. Install the conductive probe in the wash tank below the water line by at least 2 inches. Best practice is to not have the conductive probe mounted directly below the detergent feed fitting.
2. The conductive probe mounts properly in a 7/8" diameter hole. Use the gaskets and washers to provide a seal.
3. Use the crimp-on connectors and hardware provided to make electrical connections of the probe wire to the two threaded posts on the probe.
4. **Optional** Wash Tank Temperature Sensor (DEMA P/N 82.60.04). The wash tank sensor is integrated into the conductive probe. The installation is identical to the normal conductive probe, but the sensor cable will need to be routed through a knockout on the side of the enclosure and connected to the two terminals labeled "W-TEMP".

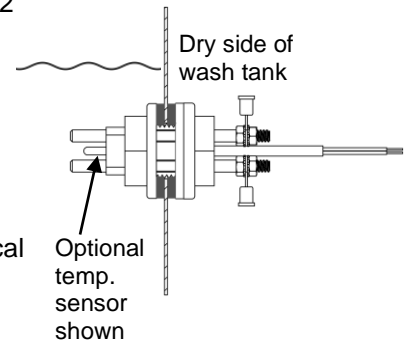

### Rinse Temperature Probe – Optional – (DEMA P/N 82.60.05)

1. The rinse temperature probe is installed at the rinse manifold. The kit includes a special adapter fitting that allows the temperature sensor and rinse chemical line to be installed.
2. Install the rinse probe inlet fitting to the machine rinse manifold by threading the 1/8" NPT into the respective fitting on the dish machine rinse manifold.
3. Slide the probe into the rinse inlet fitting, until it hits the pipe then pull it back about 1/8". Then tighten the brass nut at the end of the fitting to retain the probe.

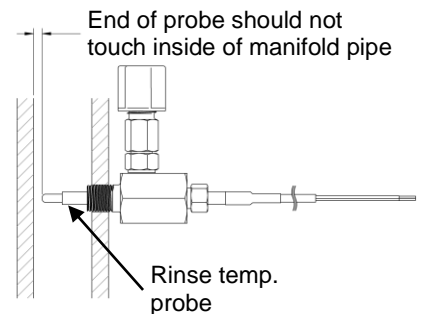

## Chemical Pump and Tubing Connections

1. Install the detergent bulkhead fitting at the wash tank.
  - a. Must be above the water line
  - b. Uses a 7/8" hole for the bulkhead mount
2. Install the rinse check valve to the rinse manifold.
  - a. Check valve uses 1/8" NPT for installation to the rinse manifold or the rinse temperature probe adapter fitting.
3. Install the 1/4" push-on fittings at the pump inlet and outlet.
4. For each chemical, install the 1/4" chemical line into the tube stiffener and place into the chemical container.
5. Route the chemical line to the inlet of the pump and install into the push-on fitting.
6. Install the 1/4" chemical line to push-on fitting at the pump outlet and route to the respective fitting at the dish machine.
  - a. Bulkhead fitting at wash tank for detergent
  - b. Rinse check valve at the rinse manifold

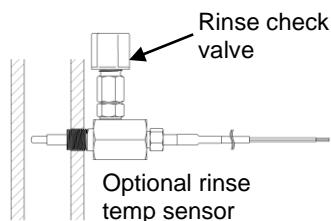
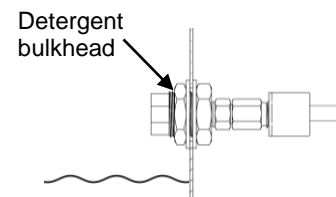

**Note:** Sanitizer pump chemical line connections are identical to the rinse connections with the exception of a Kynar (white plastic) check valve at the rinse manifold. The Kynar check valve is compatible with chlorine base sanitizer products.

## Pump Priming

1. With Pinnacle Pro showing the idle screen, press the ENTER button twice to get to the setup and pump control screen.
  - a. If the Pinnacle Pro is showing the real time screen, then the ENTER button only needs to be pressed once.
2. Using the down arrow, move the cursor to the desired pump.
3. Press ENTER to start the pump
4. Press ENTER to stop the pump
  - a. The pump operation will time out and stop the pump after 60 seconds.

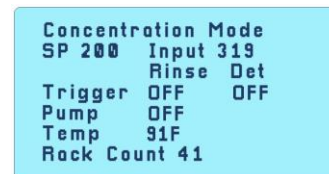
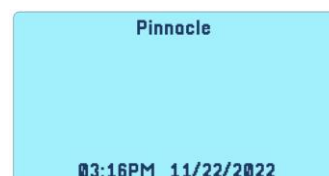

## Accessing Programming and Setup

1. With Pinnacle Pro show the idle screen, press the ENTER button twice to get to the setup and pump control screen.
  - a. If the Pinnacle Pro is showing the real time screen, then the ENTER button only needs to be pressed once.
2. Using the down arrow button move the cursor to setup dispenser and press ENTER.

See programming reference guide I1406 for all programming features.

## Dema Smarttech App

Alternatively, the Pinnacle Pro can be programmed using the DEMA Smarttech App. The Smarttech App is compatible with iOS (I-Phone and I-Pad) and Android devices as well. Go to the respective app store and search "DEMA Smarttech". The app connects using Bluetooth. The programming experience is very intuitive. The programming reference guide can be used to help understand the various settings.

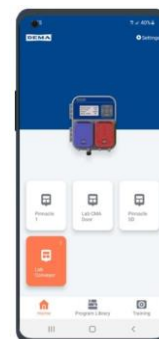

## Servicing - Replacement Parts - Optional Kits

### Pinnacle Pro Wiring Diagram – Detergent Pump or Valve and Rinse Pump

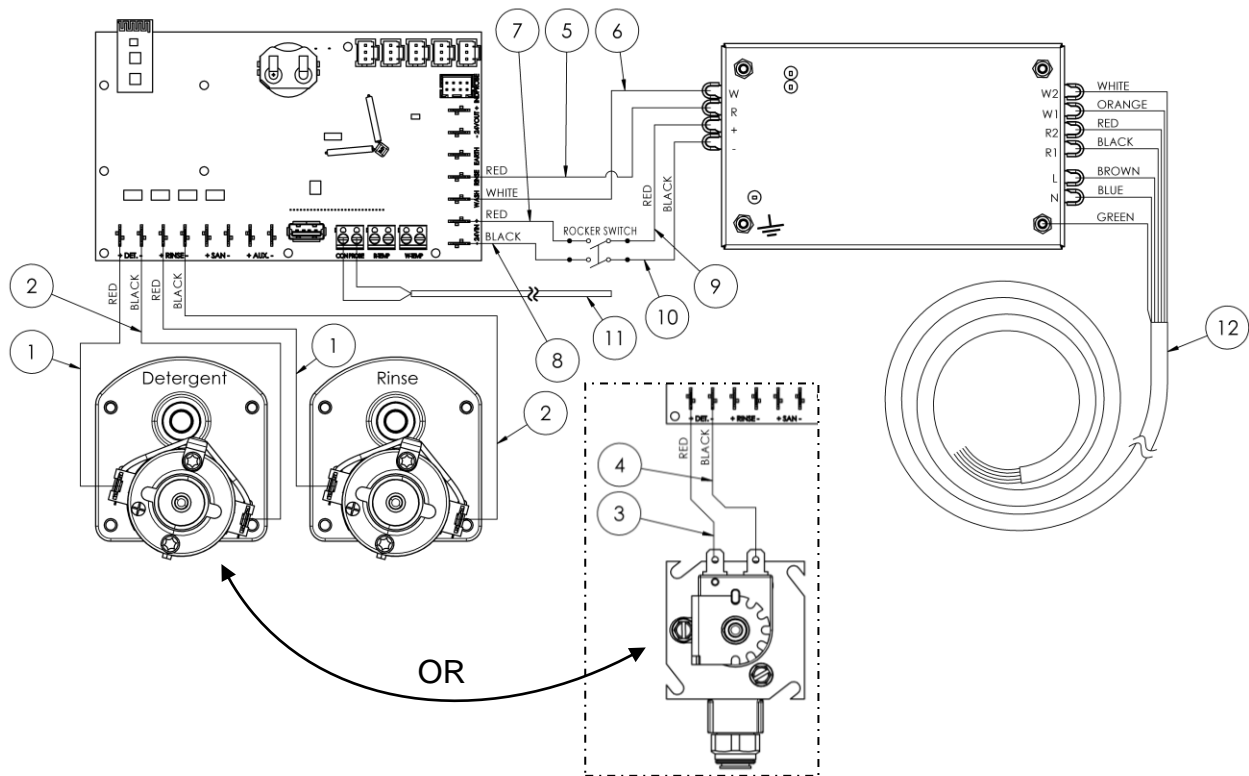

NO.	DEMA NO.	DESCRIPTION
1	81.32.71	PUMP MOTOR CABLE - RED
2	81.32.72	PUMP MOTOR CABLE - BLACK
3	81.32.79	DETERGENT VALVE CABLE - RED
4	81.32.80	DETERGENT VALVE CABLE - BLACK
5	81.32.75	RINSE TRIGGER CABLE - RED
6	81.32.76	WASH TRIGGER CABLE - WHITE
7	81.32.77	POWER CABLE - RED – POWER SWITCH TO CONTROL BOARD
8	81.32.78	POWER CABLE - BLACK – POWER SWITCH TO CONTROL BOARD
9	81.32.73	POWER CABLE - RED - POWER SUPPLY TO POWER SWITCH
10	81.32.74	POWER CABLE - BLACK - POWER SUPPLY TO POWER SWITCH
11	81.181.3	PROBE CABLE
12	82.60.03	POWER/TRIGGER CABLE KIT

### Pinnacle Pro Detergent Pump Kit (82.60.08)

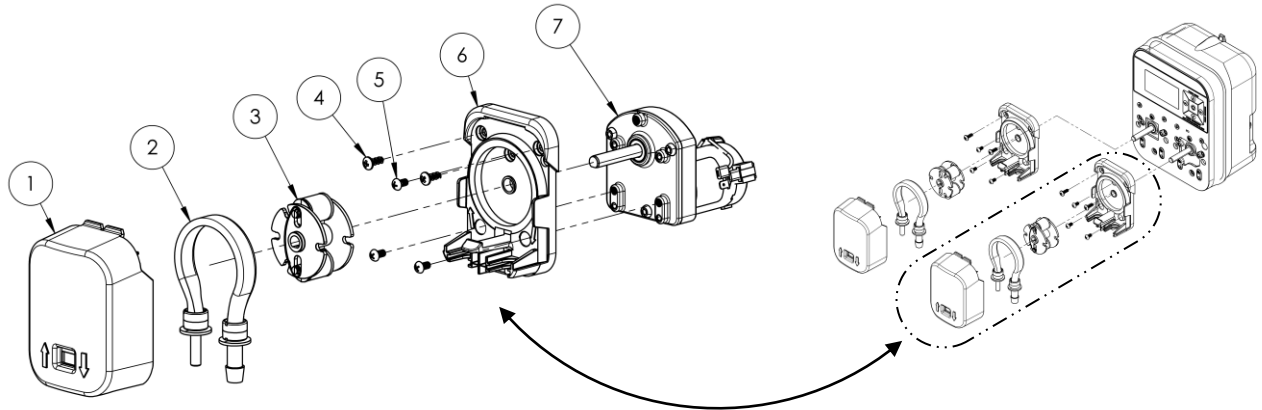

NO.	DEMA NO.	DESCRIPTION
1	41343.1	PUMP BORE COVER, LARGE, RED
2	81.177.1	SQZ. TUBE ASSY, EPDM 1/4"X1/4" FTNG, DETERGENT
3	81.172.1	ROLLER BLOCK ASSEMBLY, LARGE (2 ROLLER)
4	44.116.1	#8-18 X 1/2" SS. HI-LOW PAN HEAD SCREW
5	41.63.1	#8-32 X 5/16" SS. RND. HEAD MACHINE SCREW
6	41214.1	PUMP BASE, LARGE
7	82.60.06	GEARMOTOR 24VDC KIT W/ SCREWS - 60RPM NOMINAL

### Pinnacle Pro Rinse/Sanitizer Pump Kit (82.60.09)

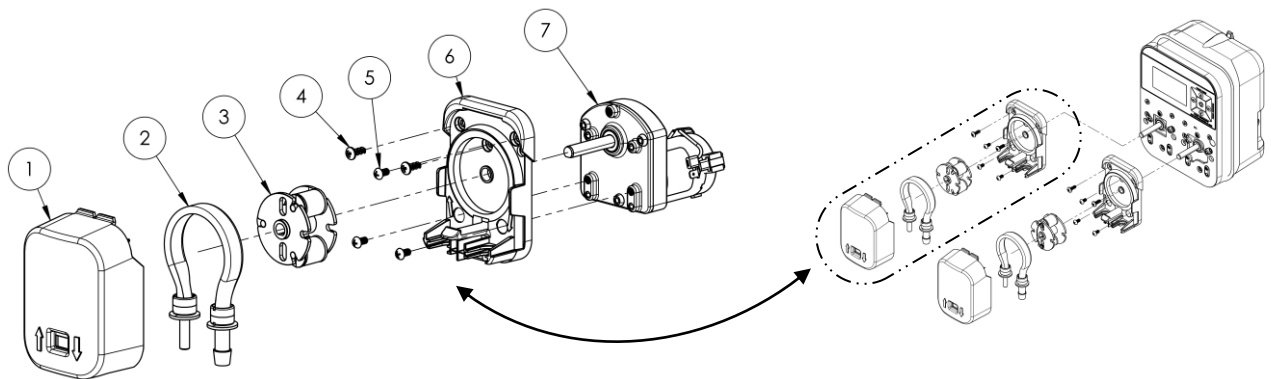

NO.	DEMA NO.	DESCRIPTION
1	41343.2	PUMP BORE COVER, LARGE, BLUE
	41343.3	PUMP BORE COVER, LARGE, YELLOW
2	81.177.2	SQZ. TUBE ASSY. EPDM 1/8" X 3/8" FTNG, RINSE/SANITIZER
3	81.172.2	ROLLER BLOCK ASSEMBLY, LARGE (3 ROLLER)
4	44.116.1	#8-18 X 1/2" SS. HI-LOW PAN HEAD SCREW
5	41.63.1	#8-32 X 5/16" SS. RND. HEAD MACHINE SCREW
6	41214.1	PUMP BASE, LARGE
7	82.60.07	GEARMOTOR 24VDC KIT WITH SCREWS - 15RPM NOMINAL

Note: All parts shown can be used on the sanitizer pump.

**Pinnacle Pro Solenoid Valve Kit (82.60.14)**

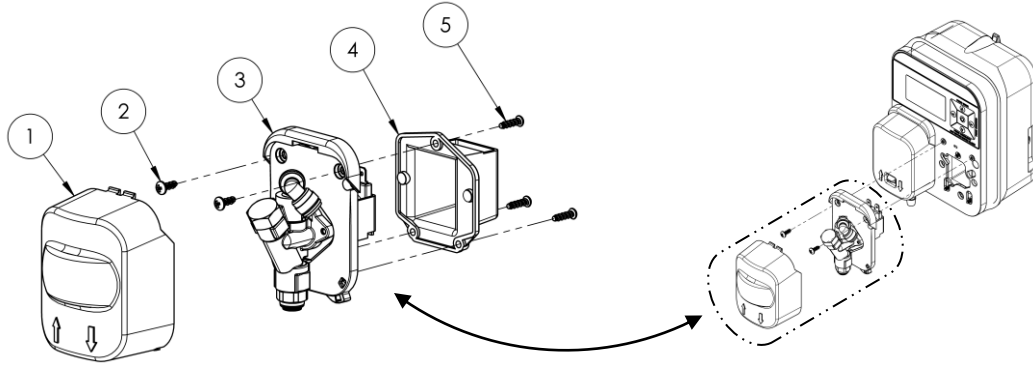

NO.	DEMA NO.	DESCRIPTION
1	41380.1	VALVE COVER, RED
2	44.116.1	#8-18 X 1/2" SS. HI-LOW PAN HEAD SCREW
3	X41331.1	VALVE & MOUNTING PLATE ASSEMBLY
4	41406.1	SOLENOID BACK COVER
5	44.116.1	#8-18 X 1/2" SS. HI-LOW PAN HEAD SCREW

## Electronics and Hardware Parts

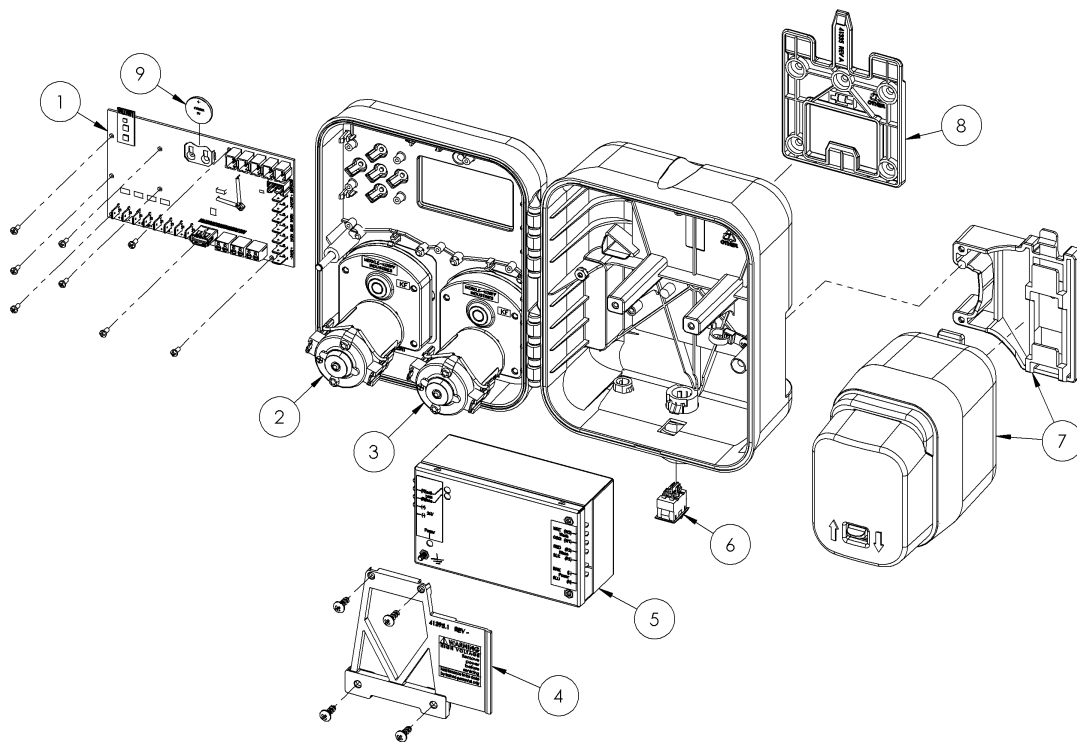

NO.	DEMA NO.	DESCRIPTION
1	82.60.01	CONTROL BOARD W/ MOUNTING SCREWS KIT
2	82.60.06	DETERGENT MOTOR LARGE W/ MOUNTING SCREWS KIT
3	82.60.07	RINSE MOTOR LARGE W/ MOUNTING SCREWS KIT
4	41395.1	POWER SUPPLY RETAINER
5	82.60.02	POWER SUPPLY/ TRIGGER BOARD MODULE
6	81.163.1	POWER SWITCH
7	82.60.15	SANITIZER PUMP LARGE MOTOR MODULE W/ SCREWS KIT
8	82.60.19	WALL MOUNTING BRACKET W/ MOUNTING SCREWS KIT
9	80.99	BATTERY CR2032

## Warranty

### Merchandise Returns

No Merchandise will be Returned for Credit Without DEMA'S Written Permission. Returned Merchandise Authorization Number is Required in Advance of Return.

### Product Warranty

DEMA products are warranted against defective material and workmanship under normal use and service for one year from the date of manufacture. This limited warranty does not apply to any products that have a normal life shorter than one year or failure and damage caused by chemicals, corrosion, physical abuse, or misapplication. Rubber and synthetic rubber parts such as "O"-rings, diaphragms, PVC tubing, and gaskets are considered expendable and are not covered under warranty. This warranty is extended only to the original buyer of DEMA products. If products are altered or repaired without prior approval of DEMA, this warranty is void. Defective units or parts should be returned to the factory with transportation prepaid. If inspection shows them to be defective, they will be repaired or replaced without charge, F.O.B. factory. DEMA assumes no liability for damages. Return merchandise authorization number must be granted in advance of returned units for repair or replacement.