

Dema 831 Laundry Master™ Installation Instructions



831-1-5 Laundry Master Shown

Dema 831 Laundry Master™ Installation Instructions

System Overview

The DEMA 831 Laundry Master is designed for long reliable use with simplicity in mind for both the installer and user. The system is based on the reliable DEMA peristaltic pump. The pumps are installed in a heavy plastic housing with a sealed cover that uses a Lexan label for access of external control and visible indicators. Pumps are available with two different motor/gear box speeds, 60 and 105 RPM.

There are two circuit boards, one per motor/gear box, which accept AC or DC trigger signals from the laundry machine to control the operation of the pump. All units are equipped with a built in transformer with primary voltages of 120, 208, and 240 at 50/60Hz.

Please read all instructions before proceeding with Laundry Master installation.

Laundry Room Survey

A complete survey of the laundry room or site installation should be completed in advance of starting the Laundry Master installation.

1. Locate the power connection points on the laundry machine. This power must be between 95 and 250 volts 50/60Hz.
2. Select location to mount the Laundry Master on a wall that will allow access to the chemical product containers and the chemical product feed points on the laundry machine. The Laundry Master should be kept away from moisture releasing machinery and from water being splashed on the unit.
3. Mount the Laundry Master on a wall by use of the supplied hanger. Use appropriate wall anchors when mounting on drywall.

Electrical Installation

This product is designed only to be used as described in this instruction sheet. Adhere to all warnings and cautions identified in this document.



WARNING: Electrical and grounding installation of DEMA products must comply with electrical codes and regulations established by national, city, county, parish, provincial or other agencies. It is possible that electrical codes and regulations require that a certified electrical contractor or engineer perform the electrical installation. For questions, contact a certified electrician.

DISCONNECT ALL ELECTRICAL POWER TO THE DISPENSER AND THE APPLIED MACHINE WHEN SERVICING- FOLLOW LOCKOUT / TAGOUT PROCEDURES.



WARNING: Installations must conform to all local and national plumbing codes and use approved backflow prevention and pressure relief devices where required.

ALWAYS DISCONNECT DISPENSER FROM WATER SOURCE WHEN DISPENSER IS NOT IN USE.



Always read SDS for all chemicals used and follow personal protective guidelines.

Dema 831 Laundry Master™ Installation Instructions

1. All electrical power must be turned off to the laundry machine and any other circuit that is to be used for this installation. Lockout and tag procedures must be observed when installing this device. Never open the DEMA Laundry Master while power is applied. Signals may be active from laundry machine, even with the DEMA Laundry Master power turned off. Use appropriately rated insulated wiring, electrical fixtures and other materials that meet all applicable electrical and building codes.
2. Connect the power to the Laundry Master. This may be 120VAC, 208VAC or 240VAC. Power should be applied to Laundry Master anytime the laundry machine is on. Some laundry machines have a terminal block setup for power, see schematic or owners manual for the specific machine being used. Locate the power terminal block inside the Laundry Master enclosure. Connect “hot” or “live” wire to the terminal labeled “line”. Connect the “return line” to the appropriate terminal block position based on supply voltage. The “earth ground” wire must be connected to one of the transformer screws by use of a ring connector (supplied in installation kit). The power line should be secured by use of proper electrical fitting through access hole in Laundry Master enclosure. The power line must also be secured and routed properly.
3. Connect the trigger signal output to the Laundry Master. The trigger signals may be between 24VAC or DC and 240VAC or DC. Some laundry machines are equipped with a terminal block that is designed to feed these signals. Locate the trigger connection points on the circuit boards inside the Laundry Master enclosure (See wiring diagram and figure 3). Run appropriate wiring between the laundry machine trigger connection points and the Laundry Master trigger connection points. Trigger line should be secured properly by use of proper electrical fitting through access hole in Laundry Master enclosure. The signal line must also be properly secured and routed properly between the laundry machine and Laundry Master enclosure.

Model Number	Quantity of Transformers	Schematic
831-1-1	1	A
831-1-2	2	B
831-1-3	1	A
831-1-4	2	B
831-1-5	1	A
831-1-6	2	B
831-1-7	1	A
831-1-8	2	B

Dema 831 Laundry Master™ Installation Instructions

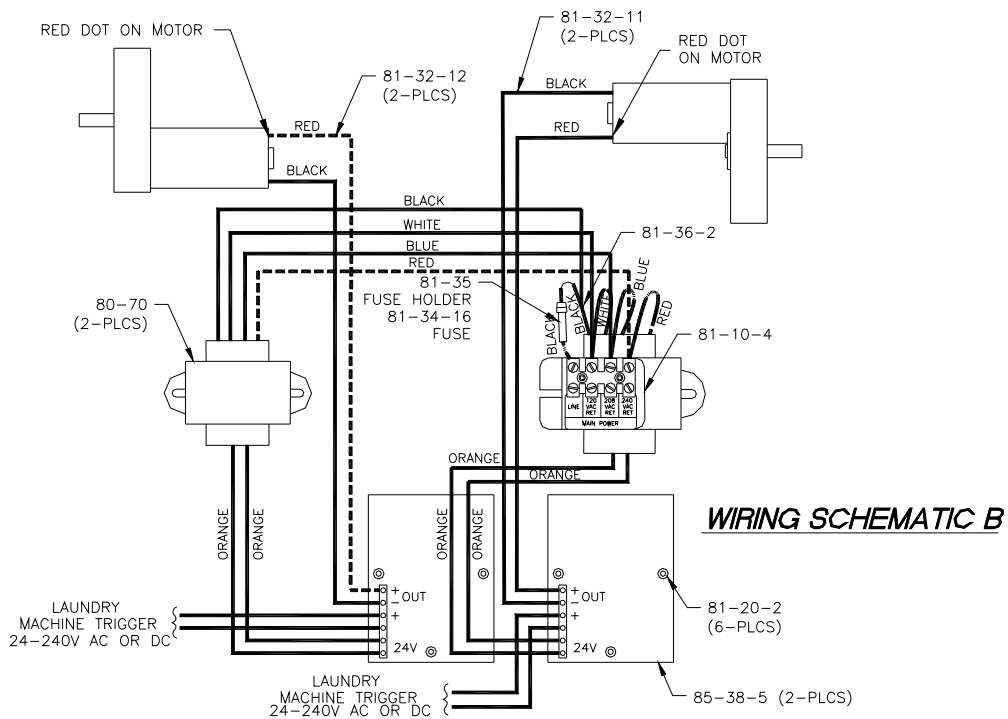
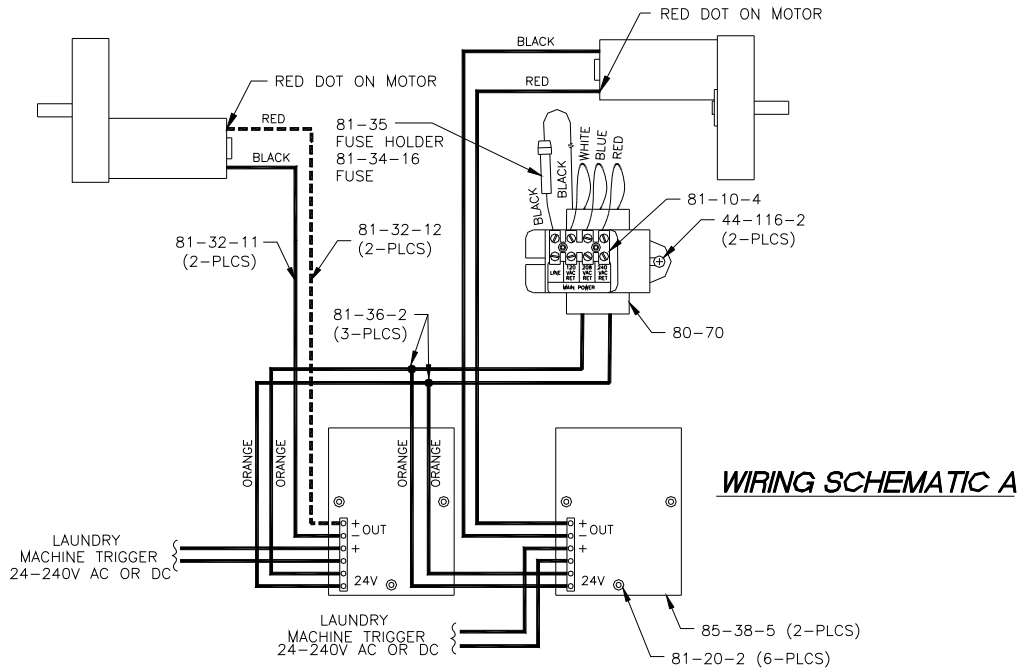

Dema 831 Laundry Master™ Installation Instructions

Tubing Connections

Always wear protective clothing and safety eyewear when working with chemicals.

Included in the installation kit is a 20ft roll of LDPE tubing per pump to connect from the chemical container, via the pump, and to the fittings on the machine.

Liquid Detergent (pump)

Measure the length of the tubing needed for the suction side from the chemical container to the inlet of pump and cut the tubing to the proper length. Install LDPE tubing into pick-up tubes (gray PVC) through compression nut until the tube is within ¼” of the other end of pickup tube. Tighten nut to secure. When properly installed the LDPE tubing will not stick out the open end of pick up tube. Route the tubing to the suction side of the pump and insert into squeeze tube approximately ½”. Secure the tubing together by tightening a cable tie around the squeeze tube. Use the same procedure on the outlet of the squeeze tubing and route the LDPE tubing to the injection feed points of the machine. Cut off all excess tubing and keep tubing away from hot surfaces and sharp edges to prevent damage or leakage.

Dry Detergent (valve)

Use ¼” compression fittings to connect ¼” LDPE tubing between the outlet of the solenoid valve on Laundry Master and the inlet of the siphon breaker on the dry chemical product dispenser.

At this point the Laundry Master installation is complete.

PROGRAMMING, OPERATION AND SETUP (Jumpers and Lockout Time)

General Operation

When a trigger signal is received from the laundry machine, the control will run its program. A two-second delay will occur to make sure the trigger is not a false signal. The control will then delay operation for the programmed delay time. This allows the laundry machine time to fill with water before adding chemical. At the end of this delay the pump will run for the programmed time. The control will then lockout, preventing re-triggering for programmed period of time.

Jumper Installation

See figure 1, 2, and 3 for proper jumper installation.

- When the jumper is in the off position the board is setup for receiving triggers from the laundry machine (See Figure 2).
- When the jumper is in the on position, the control board is setup to operate using the DEMA optional remote kit (See Figure 1).

Dema 831 Laundry Master™ Installation Instructions

JUMPER SHOULD BE ON THESE 2 PINS WHEN USING THE REMOTE SWITCH KIT

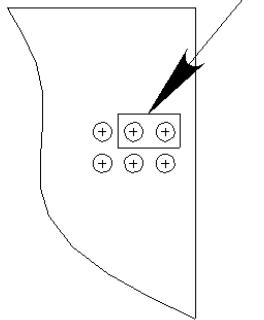

Figure 1

JUMPER SHOULD BE ON THIS PIN WHEN USING A TRIGGER SIGNAL FROM A LAUNDRY MACHINE

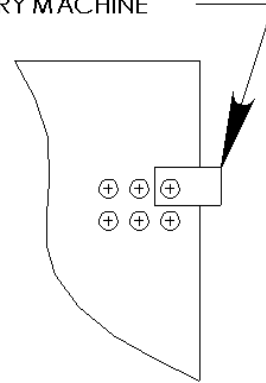

Figure 2

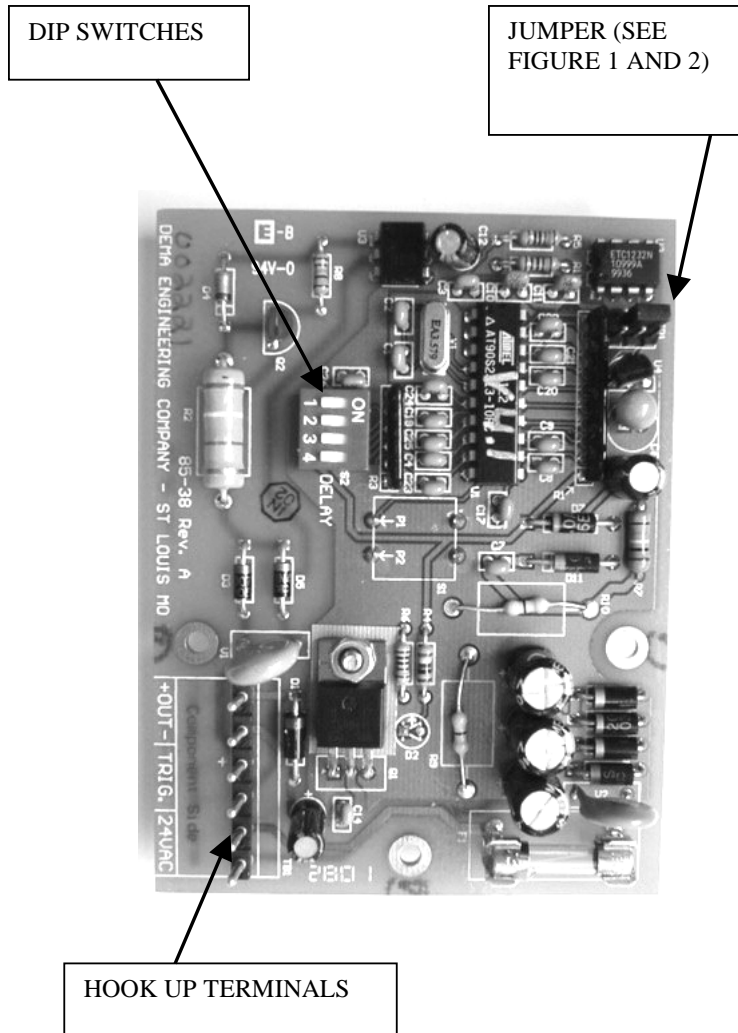

Figure 3

Dema 831 Laundry Master™ Installation Instructions

Programming

It is helpful to know the amount of chemical product to be dispensed before programming the Laundry Master. To assure that a specific application is satisfied, it is recommended that the output rate of the specific chemical product be measured by use of a graduated cylinder.

The programming function will set the delay time and the amount of time that the pump will run when a trigger signal is received from the laundry machine.

1. Note that the front face of the Laundry Master has a button labeled “PROG/PRIME” and a round window labeled “CHARGE”.
2. Press and hold the “PROG/PRIME” button to activate the programming function. The “CHARGE” light will illuminate. Continue holding the button for about 8 seconds until charge light goes out, turns on, and then begins flashing. Release the button.
3. The “CHARGE” light will continue to flash. The delay time is now being recorded. This time can be set between 0 and 4 minutes 15 seconds.
Note: The delay time has been extended on some new units to have a maximum setting of 60 minutes. To identify if the unit to be programmed has this capability look for a label on one of the components on the circuit board that reads V6.0. If the label reads anything but V6.0 it only has a maximum delay time setting of 4 minutes and 15 seconds.
4. Press the “PROG/PRIME” to stop the delay time. The pump will begin to run. The pump run time is now being recorded. The minimum amount of time is 1 second and the maximum amount of time is 4 minutes and 15 seconds.
5. Allow Laundry Master to pump for the desired amount of time. Push the “PROG/PRIME” button to set that amount of time and exit the programming function.

Lockout Time

The lockout time is set via four DIP switches found on the control board inside the Laundry Master enclosure. See Figure 3 for DIP switch location.

Lockout Time	Switch 1	Switch 2	Switch 3	Switch 4
0 Minutes	OFF	OFF	OFF	OFF
5 Minutes	ON	OFF	OFF	OFF
10 Minutes	OFF	ON	OFF	OFF
15 Minutes	ON	ON	OFF	OFF
20 Minutes	OFF	OFF	ON	OFF
25 Minutes	ON	OFF	ON	OFF
30 Minutes	OFF	ON	ON	OFF
35 Minutes	ON	ON	ON	OFF
40 Minutes	OFF	OFF	OFF	ON
45 Minutes	ON	OFF	OFF	ON
50 Minutes	OFF	ON	OFF	ON
55 Minutes	ON	ON	OFF	ON
60 Minutes	OFF	OFF	ON	ON
65 Minutes	ON	OFF	ON	ON
70 Minutes	OFF	ON	ON	ON
75 Minutes	ON	ON	ON	ON

Dema 831 Laundry Master™ Installation Instructions

Testing the Program

Pressing and holding the “PROG/PRIME” button activates the test function. The “CHARGE” light will illuminate. Continue holding the button for about five seconds until charge light goes out. Release the button. Then press and release “PROG/PRIME” button within ½ second. The “CHARGE” light will illuminate indicating the program is running. It will stay illuminated for the delay time. The light will be illuminated and the pump will run for the programmed time. The lockout time will be ignored at the end of the test.

Priming

The prime function will run the pump for the length of time that the “PROG/PRIME” button is pressed. This function is used to prime an empty suction and discharge tube. Pressing and holding the “PROG/PRIME” button activates the prime function. The “CHARGE” light will illuminate. Continue holding the button for about five seconds until charge light goes out. Release the button. Then press and hold “PROG/PRIME” button for as long as needed to prime the pump and tubing.

Replacement Parts

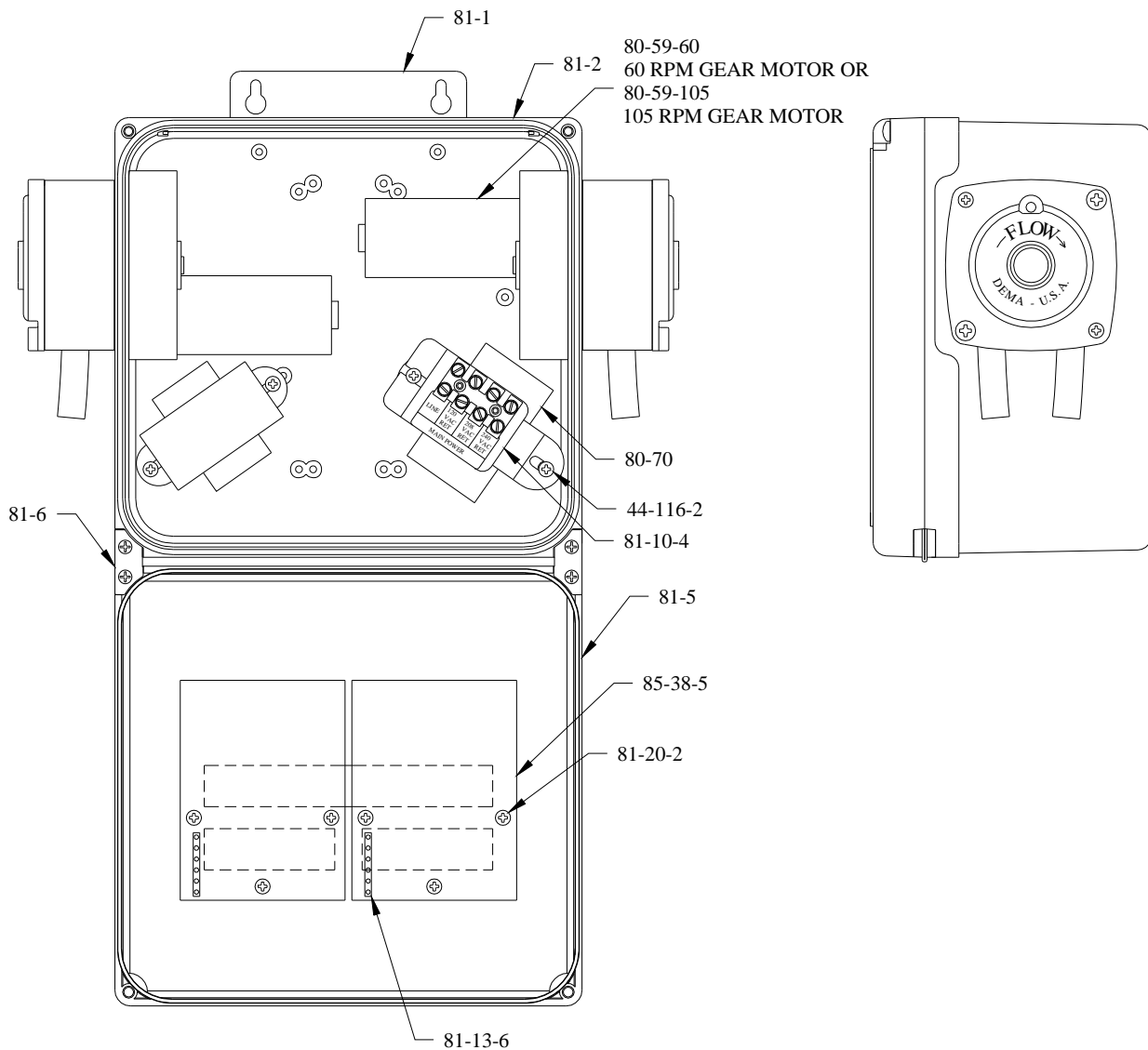

Dema 831 Laundry Master™ Installation Instructions

Dema 831 Laundry Master™ Installation Instructions

General Replacement Parts and Accessories	
Part Number	Description
81-1	Mounting Bracket Kit
81-6	Hinge and Screw Kit
25-68-20	20 ft ¼" O.D. LDPE Tubing (used on C2 Pump)
25-68-40	40 ft ¼" O.D. LDPE Tubing (used on C2 Pump)
25-68-60	60 ft ¼" O.D. LDPE Tubing (used on C2 Pump)
25-68-80	80 ft ¼" O.D. LDPE Tubing (used on C2 Pump)
25-68-100	100 ft ¼" O.D. LDPE Tubing (used on C2 Pump)
25-68-120	120 ft ¼" O.D. LDPE Tubing (used on C2 Pump)
25-115	20 ft 3/8" O.D. LDPE Tubing (used on C4 Pump)
25-115-40	40 ft 3/8" O.D. LDPE Tubing (used on C4 Pump)
25-115-60	60 ft 3/8" O.D. LDPE Tubing (used on C4 Pump)
25-115-80	80 ft 3/8" O.D. LDPE Tubing (used on C4 Pump)
25-115-100	100 ft 3/8" O.D. LDPE Tubing (used on C4 Pump)
25-115-120	120 ft 3/8" O.D. LDPE Tubing (used on C4 Pump)
80-66	10" PVC Pick Up Tube (used with ¼" LDPE tubing)
80-66-2	18" PVC Pick Up Tube (used with ¼" LDPE tubing)
81-2	Laundry Master box with gasket and threaded inserts
81-5	Laundry Master box lid with captive screws
80-70	Transformer (40VA)
81-10-4	Terminal Block and Bracket Assy
44-116-2	#8 X 3/8" Hi-Lo Screw (used for mounting transformer)
85-38-5	Single Product Laundry Control Board (circuit board)
81-20-2	#4 Hi-Lo Screw (used for mounting circuit board)
81-13-6	Modular 6 Pole Terminal Block (used on circuit board)
80-59-60MK	60 RPM Gear/Motor
80-59-105MK	105 RPM Gear/Motor

Dema 831 Laundry Master™ Installation Instructions

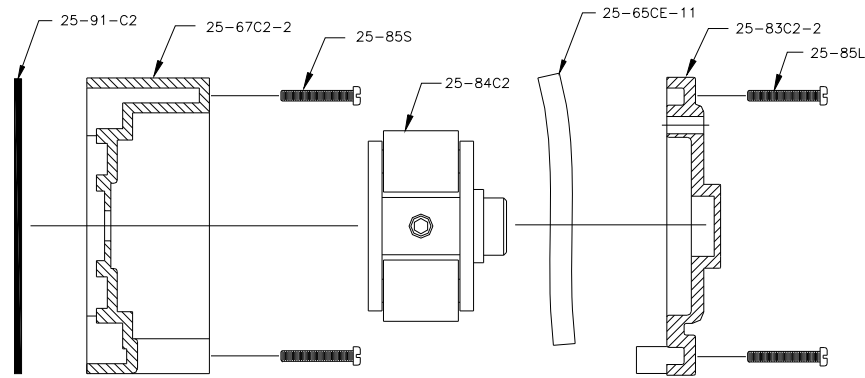

C2 PUMP ASSEMBLY

Pump Parts (not stacked)	
Part No.	Description
25-91-C2	C2 Pump Head Gasket
25-67C2-2	C2 Pump Head
25-84C2	C2 Roller Block (2 roller)
25-83C2-2	C2 Face Plate
25-85S	#10-32 X 1 3/4" Machine Screw
25-85L	#10-32 X 2 1/4" Machine Screw
25-65CE-11	Squeeze Tube for C2 pump
25-C2D	C2 Pump Head Kit (kit includes C2 Pump parts listed above)

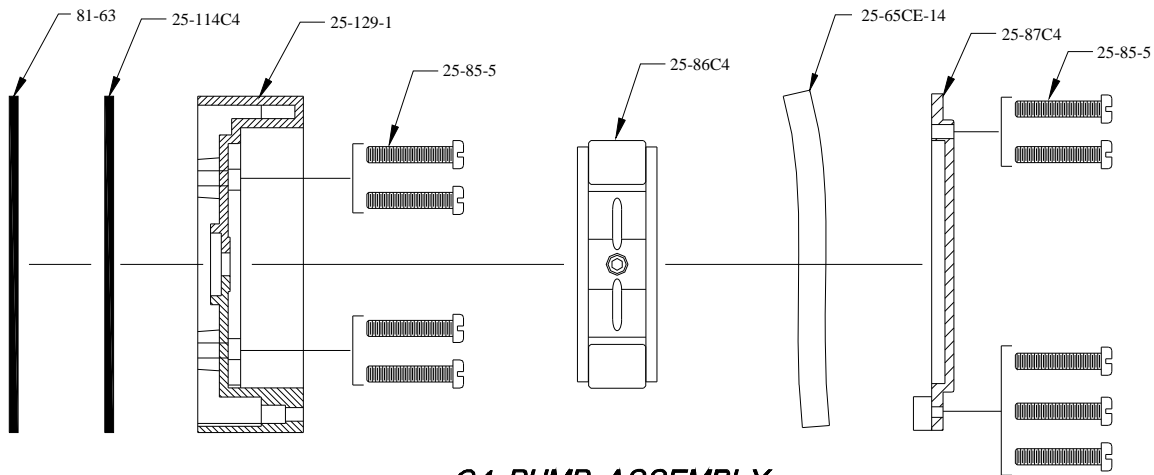

C4 PUMP ASSEMBLY

C4 Pump Parts	
Part No.	Description
81-63	C4 Adapter Plate
25-114C4	C4 Pump Head Gasket
25-129-1	C4 Pump Head Assembly
25-86C4	C4 Roller Block Assembly
25-87C4	C4 Face Plate
25-85-5	#10-32 X 1" Machine Screw
25-89CE-14	Squeeze Tube for C4 pump
25-130-1	C4 Pump Head Kit (kit includes C4 Pump parts listed above)

Dema 831 Laundry Master™ Installation Instructions

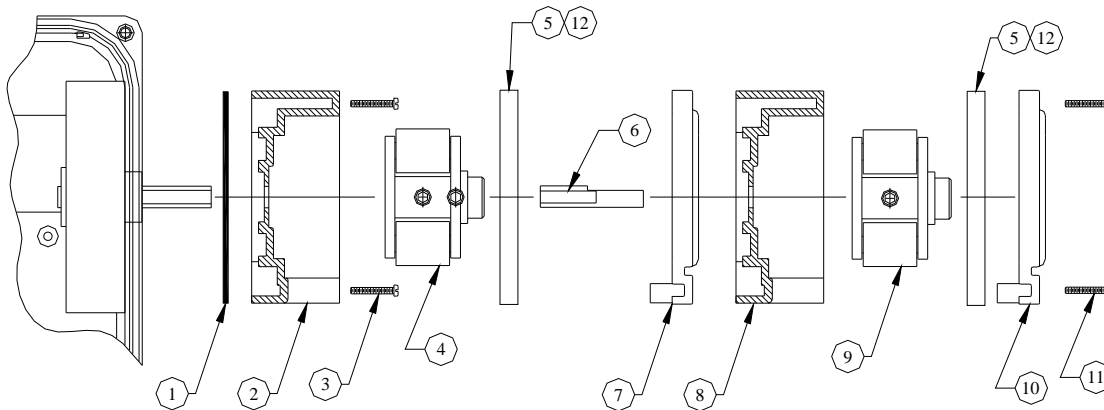

C2 STACKED PUMP ASSEMBLY

C2 Pump Parts for stacked configuration		
No.	Part No.	Description
1.	25-91-C2	C2 Pump Head Gasket
2.	25-67C2-2	C2 Pump Head
3.	25-85C	#10-32 X 1 3/4" Machine Screw
4.	25-84C2-2	C2 Roller Block (2 roller for stacked configuration)
	25-90C2-2	C2 Roller Block (3 roller for stacked configuration)
5.	25-65CE-11	Squeeze Tube (EPDM)
	25-65CV-11	Squeeze Tube (Viton)
6.	25-119	Shaft Extension
7.	25-83C2	C2 Face Plate (For tacked configuration)
8.	25-67C2	C2 Pump Head (For stacked configuration)
9.	25-84C2	C2 Roller Block
10.	25-83C2-2	C2 Face Plate
11.	25-85-17	#10-32 X 4" Machine Screw
12.	85-34	Silicone Lubricant (For Squeeze Tube)

Return Policy

No merchandise may be returned for credit without DEMA Engineering Company's written permission. Return Merchandise Authorization (RMA) number required in advance of return.

Warranty

DEMA products are warranted against defective material and workmanship under normal use and service for one year from the date of manufacture. This limited warranty does not apply to any products which have a normal life shorter than one year or failure and damage caused by chemicals, corrosion, improper voltage supply, physical abuse or misapplication. Rubber and synthetic rubber parts such as "O"-rings, diaphragms, squeeze tubing and gaskets are considered expendable and are not covered under warranty. This warranty is extended only to the original buyer of DEMA products. If products are altered or repaired without prior approval of DEMA, this warranty will be void.

Defective units or parts should be returned to the factory with transportation prepaid. If inspection shows them to be defective, they will be repaired or replaced without charge. F.O.B. factory DEMA assumes no liability for damages. Return merchandise authorization number to return units for repair or replacement must be granted in advance of return.