

Fusion Pro

700 Series Chemical Dispensers

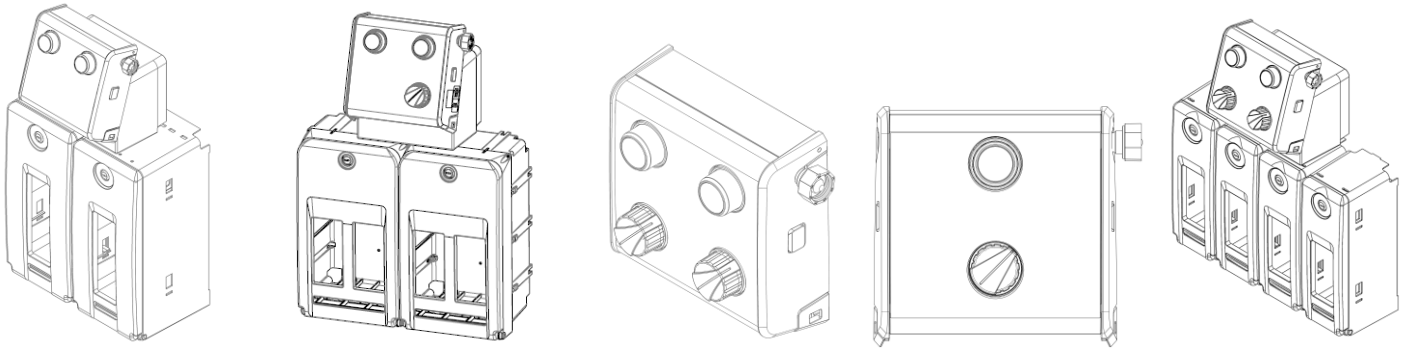

Overview

The Fusion Pro chemical dispenser series combines the proven technology of the DEMA Fusion One with a new look and modular chemical enclosures.

The dispenser series accurately dilutes chemical concentrates with water and dispenses the diluted mixture at either a high flow rate to fill buckets and scrubbers or a low flow rate to fill bottles and small containers.

Each dispenser can be set up to meet specific application needs with the ability to offer:

- High and low flow dispensing
- 1/2 Gallon (2 Liter) or 1 Gallon (5 Liter) chemical cabinets
- Selector valve option to dispense more than one chemical per dispensing unit
- Bottle filling or bucket filling
- Option of bucket or auto scrubber filling
- Supplied metering tips allow for a variety of dilution ratios

Warnings



All installations must conform to local plumbing codes and use approved backflow prevention devices. A pressure indicating tee is to be installed with existing faucets according to local plumbing codes in the state of Wisconsin and any other state that requires the use of a pressure indicating tee.



ALWAYS WEAR PROTECTIVE CLOTHING AND EYEWEAR WHEN WORKING WITH CHEMICAL PRODUCTS.

Operational Requirements

	Minimum	Maximum
Water Pressure	20 psi (1.38 bar)	95 psi (6.55 bar)
Water Temperature	-	150°F (65.5°C)

**** Recommended water pressure is between 20 psi (1.38 bar) and 80 psi. (5.52 bar). If pressure exceeds 80 psi, it is recommended that a P/N 66.43 regulator is used.**

Overall Size

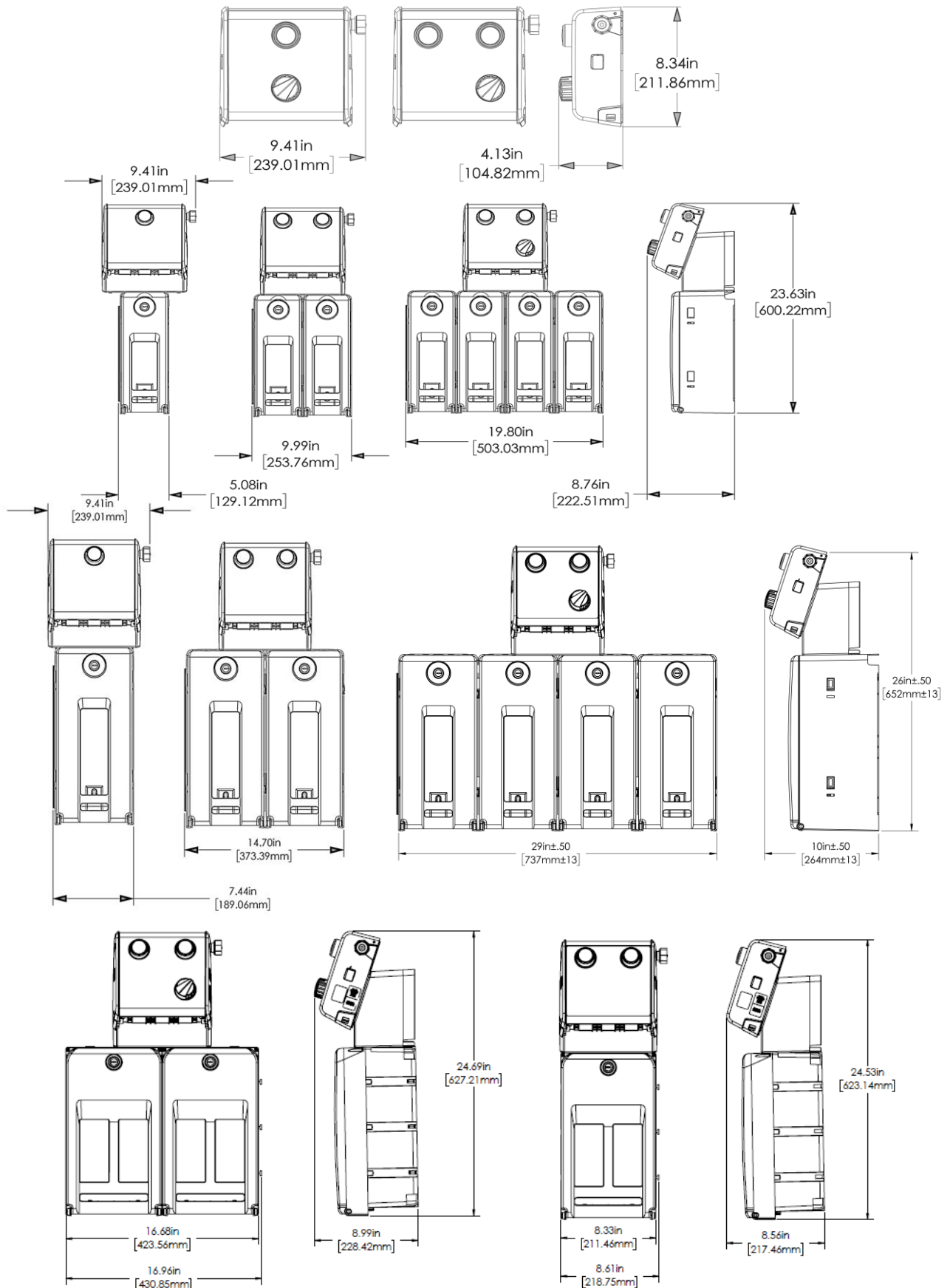

Installation and Servicing



WARNING: INSTALLATION OF DEMA PRODUCTS MUST MEET ALL APPLICABLE PLUMBING CODES AND REGULATIONS ESTABLISHED BY NATIONAL, CITY, COUNTY, PARISH, PROVINCIAL OR OTHER AGENCIES. IT IS POSSIBLE THAT PLUMBING CODES AND REGULATIONS REQUIRE THAT A CERTIFIED INSTALLATION CONTRACTOR OR ENGINEER PERFORM THE PLUMBING INSTALLATION.

1. Locate where to install the Fusion Pro dispenser. Keep the following in mind:
 - a. Mount near or over the mop sink.
 - b. Best access to water hookup.
2. Remove the Fusion Pro cover by pressing the plastic tabs on the sides of the unit and pull the cover away from the mounting bracket.
3. Determine if the water supply connection should be on the right- or left-hand side of dispenser.
 - a. The entire valve and proportioner assembly can be removed from the mounting bracket (see illustration on this page).
 - b. The water supply connection can be moved to either side by removing the plastic, orange retainer clips, the plug, and the water connection fitting. Then replace the retainer clips.

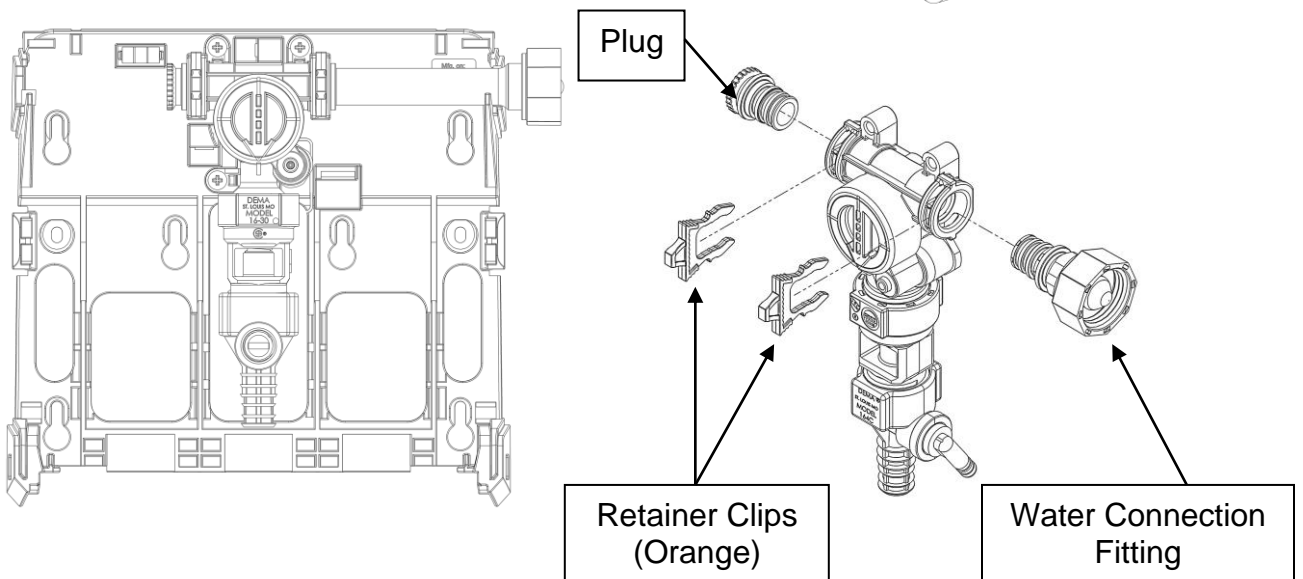
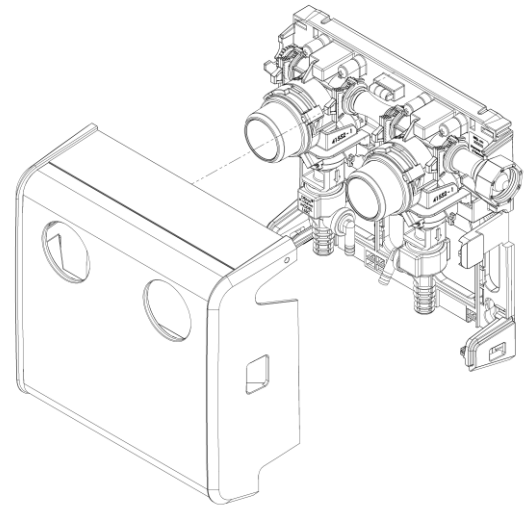
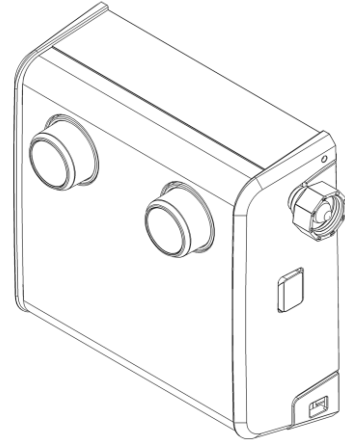

Installation and Servicing Continued...

4. Locate the four (4) key shaped mounting holes in the back plate. Mount the Fusion Pro using the mounting screws and anchors that are included in the installation kit with the aid of the integrated bubble level.
5. Install the desired metering tip by threading tip into the proportioner chemical pick-up elbow.
6. Cut the chemical supply tube to the length allows the foot valve to rest on the bottom of the chemical container. Slide the ceramic weight onto the chemical supply tube until it is against the foot valve. This will keep the foot valve at the bottom of the chemical container.
 - a. Note: Chemical containers cannot be greater than 6 feet (1.8 meters) below the Fusion Pro dispenser.
7. Install the Fusion Pro cover by positioning the top of the cover near the top of dispenser back plate and push the cover back over the valve assembly until the tab latches on side of the unit.
8. Connect the water line to the inlet of the Fusion Pro.
 - a. Note: The water pressure must be between 20psi (1.38 bar) and 95psi (6.55 bar). Optimum chemical induction occurs between 30psi (2.07 bar) – 60psi (4.14 bar).
 - b. The Fusion Pro can be used in conjunction with a pressure indicating tee, part number 68.6.QD2.

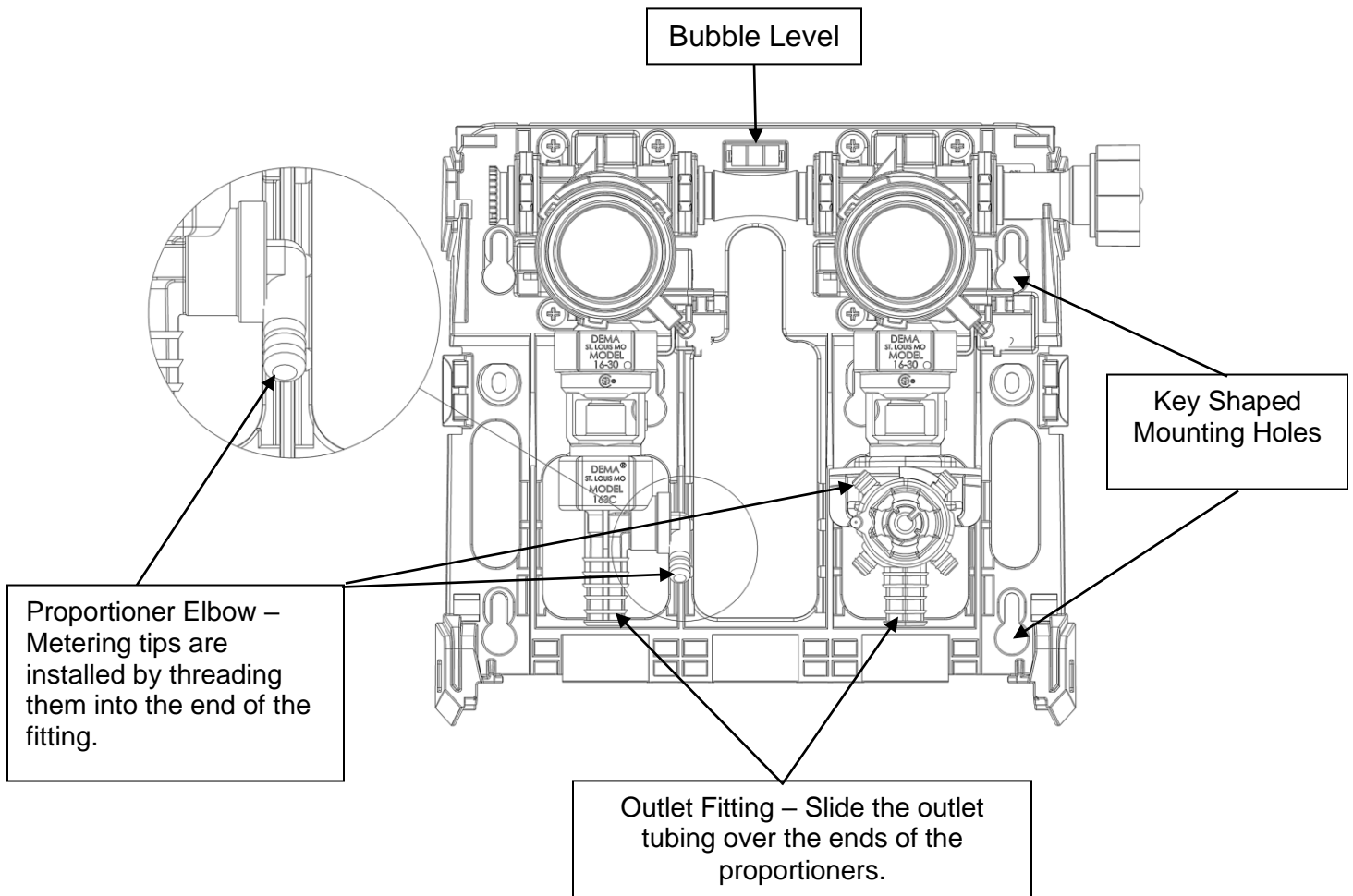

Installation and Servicing Continued...

9. Removal of Button Tab to engage Locking Activation feature (for 4GPM Proportioners).

Step 1: Remove Fusion Pro cover (see #2 above).

Step 2: Remove the Button Holder Assembly by twisting the housing counterclockwise.

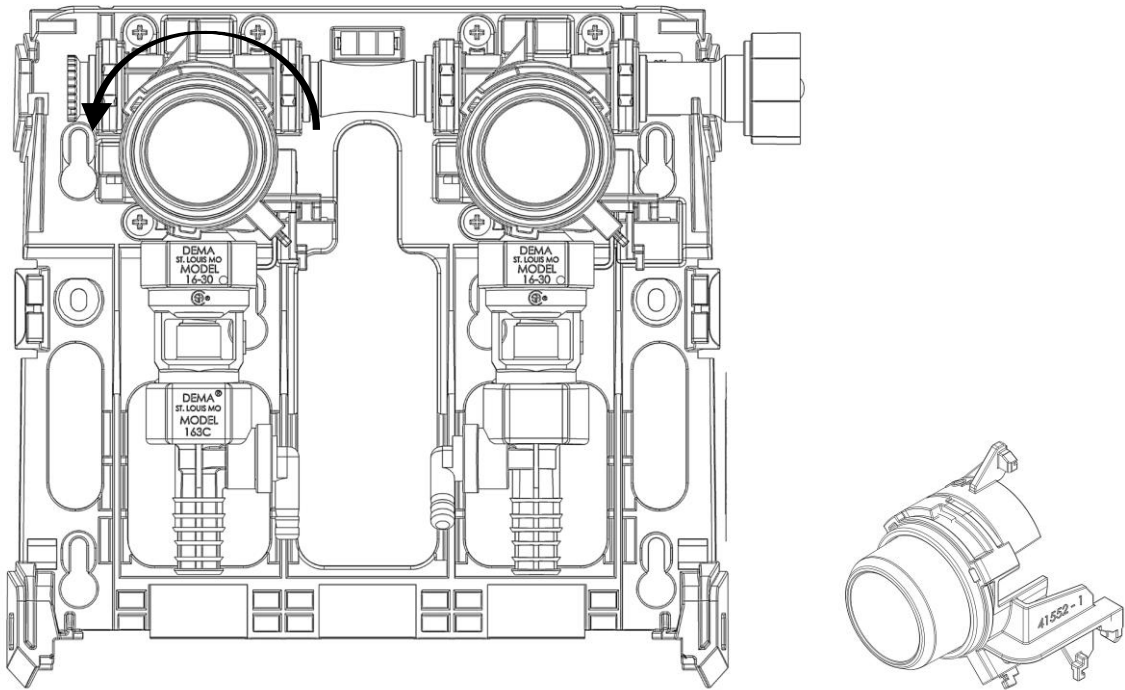

Step 3: In the interior of the button, you locate the locking tab. Break off the tab with pliers.

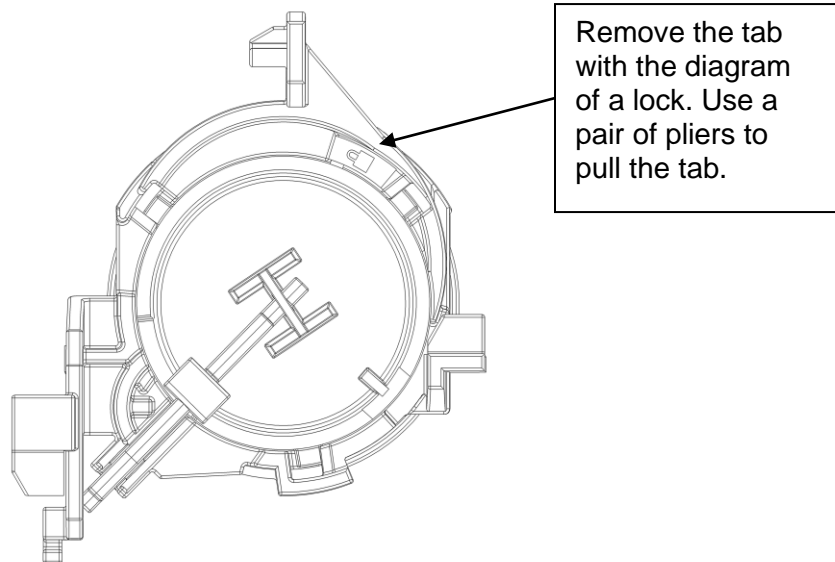

Installation and Servicing Continued...

1. To mount the Fusion Pro with Cabinet(s) and Drip Tray, follow the first 3 steps at the of the Installation and Servicing section.
2. Use the supplied key to unlock and open the cabinet door(s).
3. Position the dispenser on the wall and mark the screw locations, using the key shaped mounting holes.
4. Mount the Fusion Pro using the mounting screws and anchors that are included in the installation kit: with the aid of the integrated bubble level.
5. The Drip Tray is easily attached by sliding the hinged back into the lower window of the cabinet door. Once the hinge has been fully seated into position, push down on the front of the tray to snap it retaining clips into place.
6. The Drip Tray has an optional drainage port. It will require you to drill a hole in the port and connect some of the excess tubing to the drain port nozzle. For the best results, turn the drip tray over, and drill the hole into the drain port nozzle.

Metering Tip Kits

INDUCTION RATES BASED ON WATER THIN PRODUCTS (1 cps)
INDUCTION RATES VARY PRODUCT TO PRODUCT. FIELD TESTS ARE
RECOMMENDED.

Table 1: Metering Tips 100.15K (Provided)						
Metering Tip Color	1 GPM (3.79 LPM) Air Gap Proportioner			4 GPM (15.16 LPM) Air Gap Proportioner		
	Oz./gal	ml/L	Ratio: 1	Oz./gal	ml/L	Ratio: 1
Tan	1.37	10.57	93.65	0.37	2.91	343.19
Orange	1.67	12.91	76.48	0.44	3.45	289.14
Turquoise	1.74	13.44	73.43	0.49	3.83	260.27
Pink	3.45	26.28	37.06	0.92	7.12	139.38
Light Blue	4.47	33.73	28.65	1.10	8.49	116.74
Brown	5.04	37.87	25.41	1.40	10.80	91.62
Red	6.89	51.08	18.58	1.78	13.70	72.01
White	7.43	54.87	17.23	1.90	14.60	67.48
Green	7.46	55.06	17.16	1.98	15.26	64.53
Blue	9.14	66.63	14.01	2.54	19.44	50.45
Yellow	14.07	99.07	9.09	4.29	32.46	29.81
Black	17.36	119.45	7.37	4.53	34.19	28.25
Purple	31.36	196.81	4.08	7.67	56.53	16.69
Gray	34.95	214.51	3.66	8.77	64.15	14.59
No Tip	35.95	219.31	3.56	10.54	76.05	12.15

Table 2: Ultra Lean Metering Tips 100.15KU (Not Provided)						
Metering Tip Color	1 GPM (3.79 LPM) Air Gap Proportioner			4 GPM (15.16 LPM) Air Gap Proportioner		
	Oz./gal	ml/L	Ratio: 1	Oz./gal	ml/L	Ratio: 1
Copper	0.47	3.70	269.58	0.14	1.10	904.85
Pumpkin	0.75	5.80	171.35	0.22	1.71	585.42
Burgundy	0.87	6.75	147.10	0.25	1.98	503.37
Lime Green	1.07	8.26	120.14	0.31	2.44	408.69

Table 3: Fusion Metering Tips 100.15K (Provided)						
Metering Tip Color	1 GPM (3.79 LPM) Action Gap Proportioner			4 GPM (15.16 LPM) Action Gap Proportioner		
	Oz./gal	ml/L	Ratio: 1	Oz./gal	ml/L	Ratio: 1
Tan	0.96	7.46	133.12	0.32	2.49	399.99
Orange	1.20	9.30	106.51	0.38	2.97	335.84
Turquoise	1.43	11.01	89.81	0.45	3.50	285.06
Pink	2.26	17.36	56.62	0.79	6.15	161.72
Light Blue	2.87	21.95	44.56	1.01	7.81	127.09
Brown	3.40	25.86	37.68	1.20	9.30	106.48
Red	4.10	31.08	31.18	1.42	10.99	89.99
White	4.67	35.18	27.43	1.67	12.86	76.79
Green	4.85	36.54	26.38	1.79	13.81	71.40
Blue	6.96	51.58	18.39	2.46	18.83	52.10
Yellow	10.27	74.31	12.46	3.79	28.79	33.74
Black	12.90	91.59	9.92	4.86	36.59	26.34
Purple	26.69	172.54	4.80	11.31	81.19	11.32
Gray	30.36	191.72	4.22	13.76	97.10	9.30
No Tip	45.48	262.17	2.81	24.77	162.15	5.17

Table 4: Ultra Lean Metering Tips 100.15KU (Not Provided)						
Metering Tip Color	1 GPM (3.79 LPM) Action Gap Proportioner			4 GPM (15.16 LPM) Action Gap Proportioner		
	Oz./gal	ml/L	Ratio: 1	Oz./gal	ml/L	Ratio: 1
Copper	0.34	2.67	373.60	0.12	0.94	1060.18
Pumpkin	0.56	4.33	230.23	0.19	1.50	665.14
Burgundy	0.77	6.00	165.66	0.24	1.85	539.29
Lime Green	0.84	6.52	152.39	0.28	2.21	451.24

Note: All induction flow rates are based on a water pressure of 40 psi.

Service Note: Standard size 1/4" hose bars and metering tips that come with this model are used for water thin (1cps) products. Ratios as low as parts-per-million, can be achieved with the use of a capillary metering tip. More viscous products (75cps – 200cps) may require larger 3/8" hose bars and metering tips. If you are having difficulty achieving the ratio you require, call DEMA and ask for technical support.

Trouble Shooting

Symptom	Probable Cause	Remedy
Water valve does not shut off after use	Water pressure is above recommended range	Recommended water pressure is 30-70psi (2-5bar), install #66.43 pressure regulator
	Hole in the diaphragm	Replace the diaphragm
	Debris on the diaphragm or the valve actuation button	Rinse the diaphragm or button assembly
Proportioner continues to draw chemical after water valve is shut off	Concentrated chemical is positioned higher than the proportioner and is siphoning chemical	Move chemical container so it is lower than the proportioner
Activation button does not return to off position	Spring is missing from button	Replace spring, #64.50.1
Proportioner does not draw chemical properly	Insufficient water pressure	Minimum allowable water pressure is 20psi (1.38bar)
	Foot valve/SafeLink cap is clogged	Soak in hot water to clean
	Metering tip is clogged	Soak in hot water to clean
	Mineral deposits are located on air gap nozzle	Soak nozzle and inlet screen in hot water or in a mineral deposit removal chemical
	Proportioner elbow is loose, or O-ring seal has failed, allowing air in	Tighten seal, inspect O-ring condition, replace if needed, #63.78
	Selector valve seals have failed	Replace selector valve, #63.53.20
Air Gap is spraying or dripping	Mineral deposits are located on air gap nozzle	Soak nozzle and inlet screen in hot water or in a mineral deposit removal chemical
Leaking at Action Gap	Bucket fill tube is raised higher than proportioner	Do not raise bucket fill tube higher than proportioner, ensure dispenser is mounted a minimum of 4' (1.2m) off floor
Leaking at water valve fittings	Retainer clip (orange) is not present	Replace retainer clip, #40.854.1
	Connection between dispenser and water supply is too loose or strainer washer is missing	Inspect connection, verify strainer washer is present, tighten fittings
	Proportioner and/or backflow preventer is too loose	Inspect connections, tighten fittings

Operation

Upon completion of the installation of the Fusion Pro; dispensing of diluted chemical can be performed in several ways depending on the dispenser configuration. To operate the dispenser, follow the steps below.

1. For bottle fill dispensing, place the chemical outlet tube into the container to be filled. Use the 1 GPM proportioner for this type of dispensing.
2. Press the button to start the dispenser. Release the button once the container has filled.
3. For bucket fill dispensing, place the outlet tubing into the bucket. Follow step 2.
4. If you would like to use the locking activation feature, for dispensing to larger containers, see step 10 of the Installation and Servicing section, on page 5 of this manual.
5. To activate the locking feature, press the 4 GPM button, and then twist it clockwise. This will engage the locking feature, and it will continue to dispense until you turn the button counterclockwise and release the button.

Replacement Parts: Fusion Pro Unit

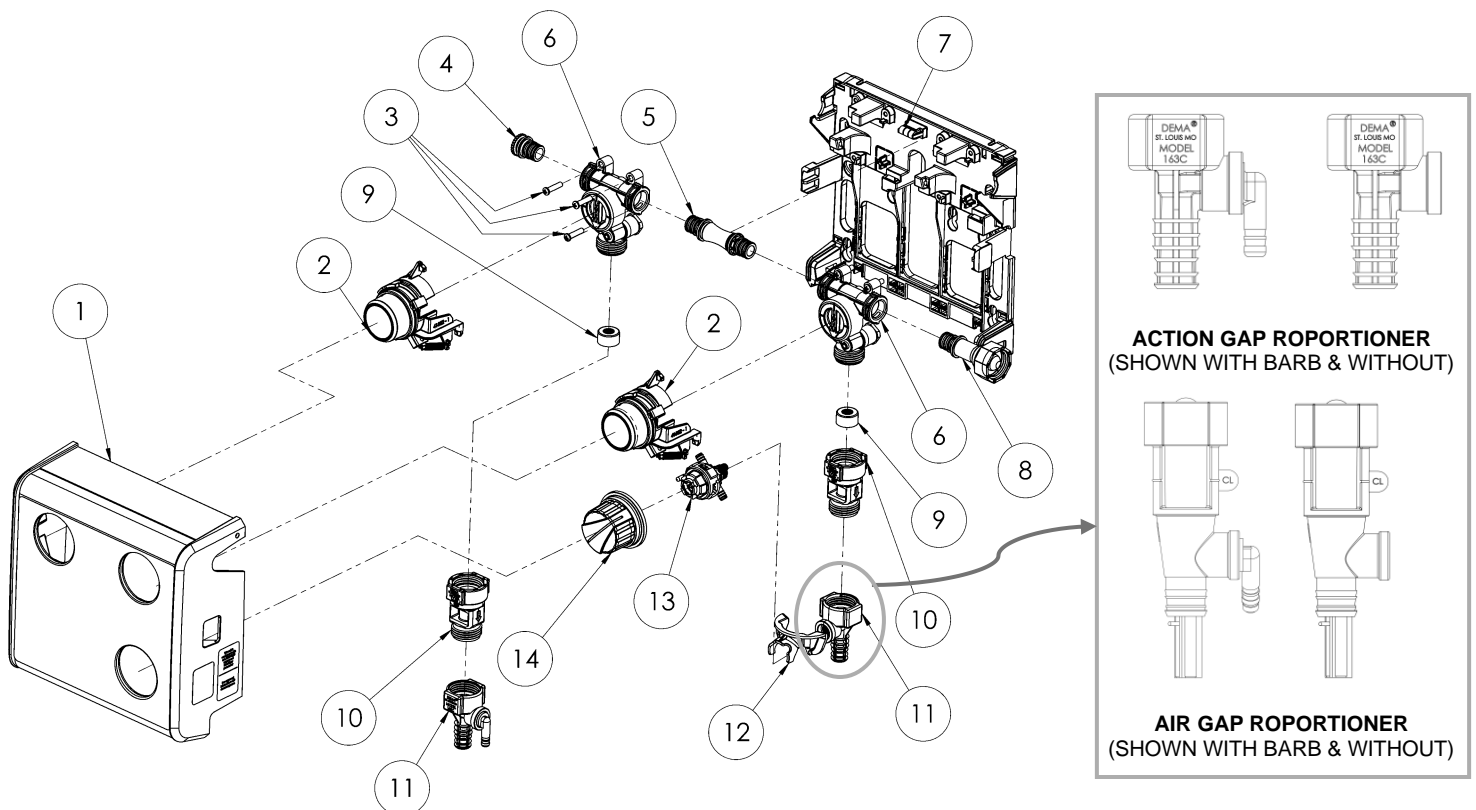

Replacement Parts: Fusion Pro Unit

ITEM NO.	PART NO.	DESCRIPTION
1	SEE NEXT TABLE	FRONT COVER ASSEMBLY KIT
2	41-768-1	BUTTON KIT - (BLACK)
	41-768-2	BUTTON KIT - (BLUE)
	41-768-3	BUTTON KIT - (RED)
	41-768-4	BUTTON KIT - (GREEN)
	41-768-5	BUTTON KIT - (YELLOW)
	41-768-6	BUTTON KIT - (WHITE)
	41-768-7	BUTTON KIT - (PURPLE)
3	44-116-5	#8 HI-LO SCREW X 3/4" LONG
4	40-926-KIT	FUSION VALVE PLUG ADAPTER KIT
5	64-70-19	FUSION VALVE CONNECTOR WITH O-RINGS
6	64-4-2	FUSION VALVE ASSEMBLY KIT - LESS FITTINGS
7	40-970-1	BUBBLE LEVEL, GREEN DIAMETER 7mm X16mm
8	64-70-15	WATER INLET MEDIUM ADAPTER (DUAL VALVE) GHT
	64-70-16	WATER INLET MEDIUM ADAPTER (DUAL VALVE) BSPP
	64-70-17	WATER INLET LONG ADAPTER (SINGLE VALVE) GHT
	64-70-18	WATER INLET LONG ADAPTER (SINGLE VALVE) BSPP
9	89-20-1	FLOW DISC ASSEMBLY (1 GPM)
	89-20-3	FLOW DISC ASSEMBLY (4 GPM)
10	16-30	ACTION GAP
11	61-99-2	1-GPM PROPORTIONER 1/4" BARB
	61-99-4	1-GPM PROPORTIONER L/BARB
	61-22-3	4-GPM PROPORTIONER 1/4" BARB
	61-22-4	4-GPM PROPORTIONER L/BARB
	61-126AG-1	1-GPM AIR GAP L/BARB
	61-126AG-4	4-GPM AIR GAP L/BARB
	61-22-3BAG-EL2	4-GPM AIR GAP 1/4" BARB
12	41-034-1	ANTI-ROTATION CLIP FOR ACTION GAP
	41-035-1	ANTI-ROTATION CLIP FOR AIR GAP
13	63-53-20	SELECTOR ASSY, L/ACC.
14	41315-1	SELECTOR KNOB

Replacement Parts: Fusion Pro Front Cover Assembly Kit

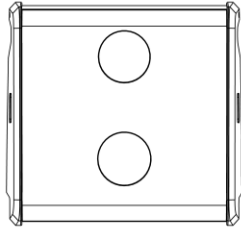

703/704
41-767-1

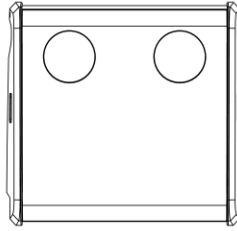

720/722/724
41-767-2 THRU 41-767-4

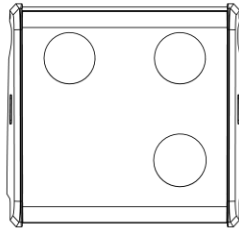

730
41-767-5

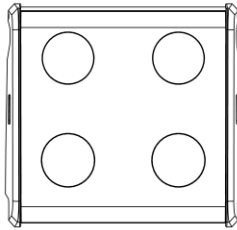

731
41-767-6

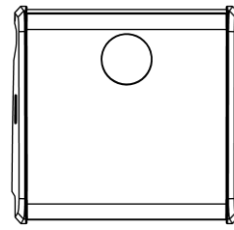

701/702
41-767-7

ITEM NO.	PART NO.	DESCRIPTION
1	41-767-1	703/704 FRONT FACE PLACE ASSEMBLY
	41-767-2	722 FRONT FACE PLACE ASSEMBLY
	41-767-3	724 FRONT FACE PLACE ASSEMBLY
	41-767-4	720 FRONT FACE PLACE ASSEMBLY
	41-767-5	730 FRONT FACE PLACE ASSEMBLY
	41-767-6	731 FRONT FACE PLACE ASSEMBLY
	41-767-7	701/702 FRONT FACE PLACE ASSEMBLY

Fusion Pro Accessories

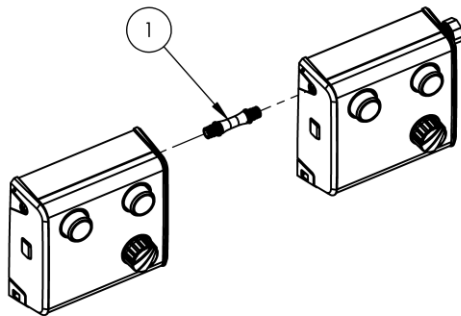

TWO BUTTON FUSION PRO COUPLED W/
TWO BUTTON FUSION PRO
USING 64-70-20 [ITEM 1]

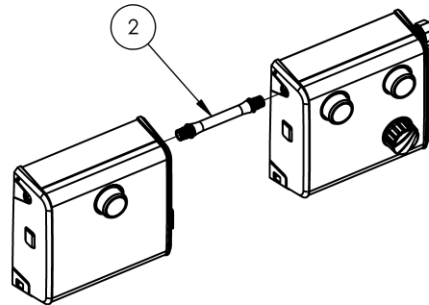

SINGLE BUTTON FUSION PRO COUPLED W/
TWO BUTTON FUSION PRO
USING 64-70-21 [ITEM 2]

ITEM NO.	PART NO.	DESCRIPTION
1	64-70-20	KIT, ADAPTER (3.34") – FOR COUPLING (TWO BUTTON FUSION PRO WITH TWO BUTTON FUSION PRO)
2	64-70-21	KIT, ADAPTER (5.34") – FOR COUPLING (SINGLE BUTTON FUSION PRO WITH TWO BUTTON FUSION PRO)

Replacement Parts: Cabinets (2L), Gallon (5L) & “Dual Use”

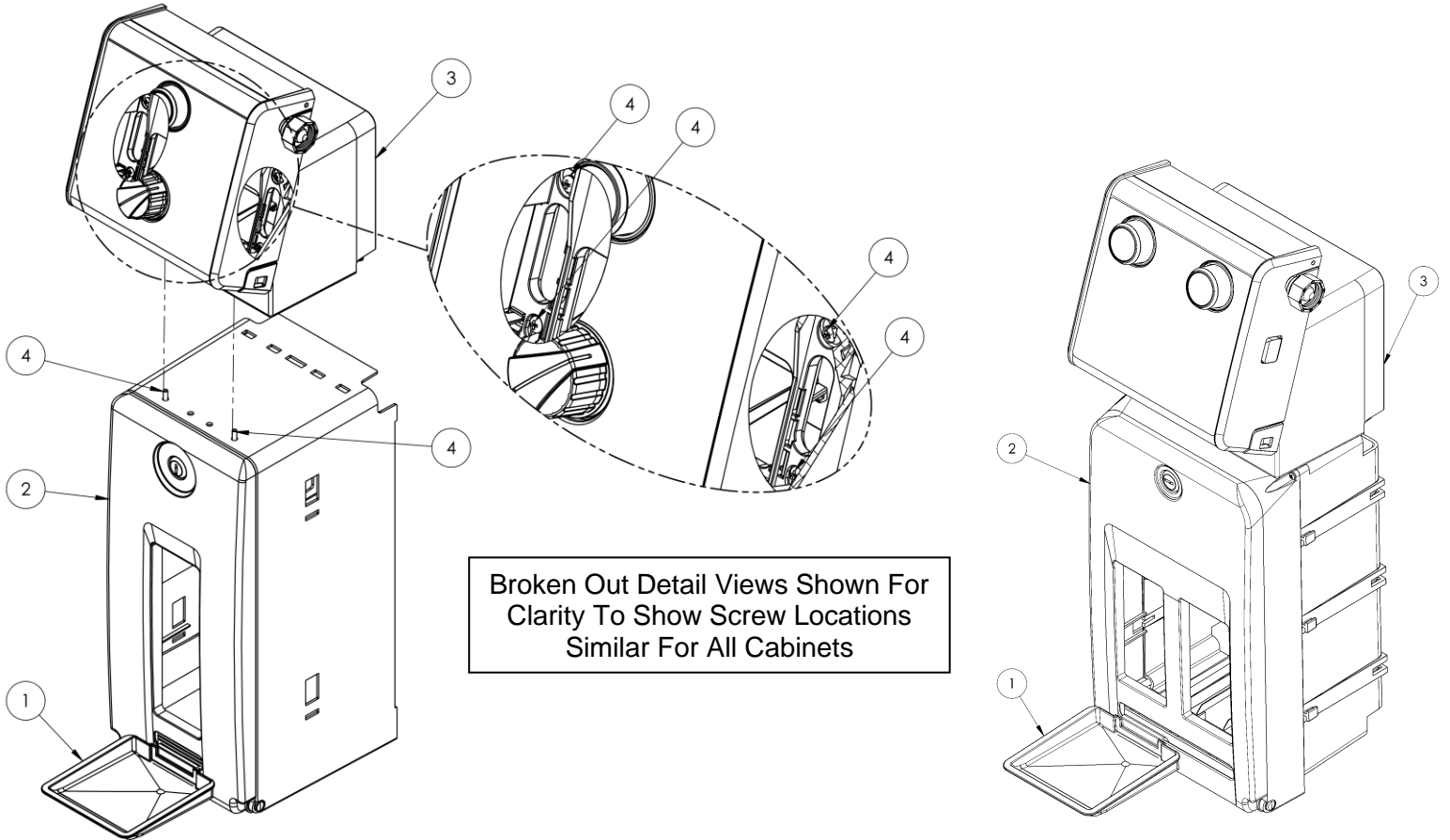

Gallon (5L) [LEFT VIEW] & “Dual Use” [RIGHT VIEW] Cabinets & Dispensers Shown for Representation Only
Actual Dispenser & Cabinet(s) May Vary from Purchased Item(s)

ITEM NO.	PART NO.	DESCRIPTION
1	41512-1	DRIP TRAY
2	89-16-5	BOX, 2-LITER (2L) CABINET ASSEMBLY
	89-17-5	BOX, 1 GALLON / 5-LITER (5L) CABINET ASSEMBLY
	89-40-1	BOX, DUAL CABINET ASSEMBLY
3	41453-1	HOUSING SUPPORT
4	44-116-1	#8 HI-LO SCREW X 1/2" LONG

Warranty

Merchandise Returns

No merchandise will be returned for credit without DEMA'S written permission. Returned merchandise authorization number is required in advance of return.

Product Warranty

DEMA products are warranted against defective material and workmanship under normal use and service for one year from the date of manufacture. This limited warranty does not apply to any products that have a normal life shorter than one year or failure and damage caused by chemicals, corrosion, physical abuse, or misapplication. Rubber and synthetic rubber parts such as "O"-rings, diaphragms, PVC tubing, and gaskets are considered expendable and are not covered under warranty. This warranty is extended only to the original buyer of DEMA products. If products are altered or repaired without prior approval of DEMA, this warranty is void.

Defective units or parts should be returned to the factory with transportation prepaid. If inspection shows them to be defective, they will be repaired or replaced without charge, F.O.B. factory. DEMA assumes no liability for damages. Return merchandise authorization number must be granted in advance of returned units for repair or replacement (See "Merchandise Returns" above).