

Effective: April 24, 2023



ADC-44 Tall L-R/R-L

ADS CONVEYOR DISHWASHER

PARTS MANUAL



If you have questions, call 800-922-2178 or visit
our website at
www.americandish.com

American Dish Service

900 Blake Street | Edwardsville, Kansas 66111
Phone: 913.422.3700 | Toll-Free: 800.922.2178 | Fax: 913.422.6630
orders@americandish.com | americandish.com

Rev 1.0 © 5/2023

The American Dish Service part numbers contained in this publication are replacement parts for equipment listed with governmental and regulatory agencies and are specified to maintain the regulatory mark and certification. These parts must only be replaced by those who are trained in the operation and service of commercial dishmachines. Aftermarket parts or modified parts are not compliant or listed with the standards of governmental and regulatory agencies; aftermarket parts are not authorized by ADS for replacement repairs. ADS will not be responsible for any liability if parts are used in the repair of the machine that are not ADS-specified, by those installing non-certified replacement parts or attempts to change the machine's cycle or operation other than as designed and certified. **Read the warnings and cautions provided below before working on or replacing parts on any ADS equipment.**



DANGER

The installation of electrical parts contained in this publication require the following precautions:

The electrical power supplied to this machine is an imminent hazard to life that could result in severe bodily injury or death if not properly installed or connected correctly. When working in the control box or on electrical parts, always disconnect power and perform the appropriate lock-out/tag-out procedure before servicing. Replace the cover to the control box and other protective covers when finished with servicing this equipment before returning the machine to normal operation.

LOOSE ELECTRICAL CONNECTIONS: Damage to the equipment can occur if the following precautions are not observed. Before connecting power to the machine, check all electrical terminals in the control box. Screws can loosen in transit. Loose connections on high amp load terminals such as the pump motor and tank heaters will cause wire burning and component damage during operation and will not be covered under ADS warranty.

"CLEAN CIRCUIT" means the electrical circuit breaker for the dishmachine supplies no other outlets, machines, or lights. GFCI outlets are not recommended for commercial dishmachines; ADS recommends that a single-rack machine be installed with the wire connection (hard-wired) directly from the circuit breaker. All high temp and conveyor equipment must be hard wired. If a plug and socket are used to provide electrical power to a dishmachine in a commercial kitchen, then according to electrical code it must be a GFCI, but not all GFCIs are the same. They must be rated for the Amp draw for the designed circuit.

For Reference: The NEC Article 210.8 regarding GFCI Protection (B) Other Than Dwelling Units (2) Commercial and Institutional Kitchens. All 15 and 20A, 125V receptacles installed in kitchens, even those that do not supply the countertop surface, must be GFCI protected.



WARNING

The chemical feeders and controls contained in this publication require the following precautions:

READ Manufacturer's Manual before Using this Product. For your safety read and observe all warnings in these instructions. While performing installation of parts described in this booklet, wear approved Personal Protective Equipment, including chemically resistant gloves and Safety Eye-Wear.

CHEMICALS: There are potentially hazardous situations when working with industrial cleaning chemicals for dishmachines. See chemical manufacturer's safe practices and SDS or MSDS sheets for handling and installing chemicals and supply containers.

Chemicals can damage or corrode plumbing and stainless parts of the dishmachine. Do not run chemical lines over controls or plumbing. Always secure chemical lines and check regularly for leaks. **If not properly handled, chemicals can cause serious bodily injury. In the event of chemical contact to skin or eyes; wash immediately with fresh water and seek medical attention.**

DE-LIMING THE MACHINE: Because of potential hazards resulting from the combination of chlorine with acid solution, only authorized trained individuals must be allowed to de-lime a commercial dishmachine.

CONTAINERS: The ADS chemical delivery system is designed for 5 gallon pails of industrial low-energy chemical products. Always use chemical resistant safety gloves and safety goggles (indirect-vented or non-vented) when changing chemical buckets. Immediately report spills and refer to your chemical suppliers SDS safety data sheet or MSDS material safety data sheet for information if chemical comes in contact with skin or eyes.

Any modifications to the chemical delivery system for smaller containers must include Closed Loop Chemical Containers (spill proof bottles) in a secured racking system. It is the responsibility of the user of the machine to purchase chemicals in spill proof containers. **FAILURE CAN RESULT IN SERIOUS INJURY.** Never place chemicals in open containers or containers that can be easily tipped over when moving or changing product. Failure to do so will void your ADS warranty.

Chemical supplies must be kept in closed delivery containers to avoid spills or contamination. Do not place chemical solutions in open containers or containers that can be easily tipped over in moving or changing.

Do not open the doors while the machine is in operation. Doing so could result in serious bodily injury from spraying hot water and chemicals.



The door lever arm parts in this publication are installed under spring tension and caution is needed whenever parts are changed. Wear safety glasses when working on the doors and lever. Care should be taken when moving, installing, or replacing any door lever arm parts. Use the ADS lever arm tool to unload the door spring during replacement or adjustment. The spring tension suddenly released can result in pinch or blunt trauma, and puncture wounds. If a wound occurs from the release of spring tension, wash the wound area immediately because of the soils that can accumulate on the metal parts and seek medical attention.

NOTICE

BEFORE YOU BEGIN: American Dish Service provides this information as a service to our customers. **Keep all instructions for future reference.** ADS reserves the right to alter or update this information at any time. Should you desire to make sure that you have the most up-to-date information, we would direct you to the appropriate document on our web site: www.americandish.com. **It is your obligation as the customer to ensure that the replacement parts for the machine are installed safely and properly, and when completed, the machine is left in proper and safe working order.** Electrical, Plumbing, and Chemical hookup must be performed by a qualified professional who will ensure that the equipment is installed in accordance with all applicable Codes, Ordinances, and Safety requirements. Failure to follow the installation instructions will void the warranty. **ADS assumes no liability or control over the installation of the equipment or replacement parts. Product failure due to improper installation is not covered under the ADS Warranty.**

Plumbing Parts:

When working on the water inlet manifold, first relieve the water line pressure by turning off the water supply to the machine then energize the machine's fill valve. By doing this the manifold will empty of water. Turn off the electrical power and lock out/tag out the machine. It will then be safe to open the plumbing inlet manifold.

TANKLESS WATER HEATERS have shown to be problematic for commercial dishmachines. It has been the experience of ADS that tankless supply systems require multiple units plumbed in sequence with a recirculation loop to achieve proper pressure and temperature.

Check with the tankless water heater manufacturer, they may recommend a storage tank to guarantee proper flow and line pressure to the machine. Failure to provide adequate water quantity, pressure and temperature to the machine will cause the machine to function improperly and is not the responsibility of ADS. Improperly installing ADS equipment or parts in this manner could void the warranty. All costs associated with providing an adequate water supply to the machine is the sole responsibility of the user.

Drain replacement parts should not be reduced in size, all drain lines should remain the same size as it exits the dishmachine or larger. If you have questions, call 800-922-2178 or visit our website at www.americandish.com.

Cabinet Assembly

ADC-44 L-R Tall

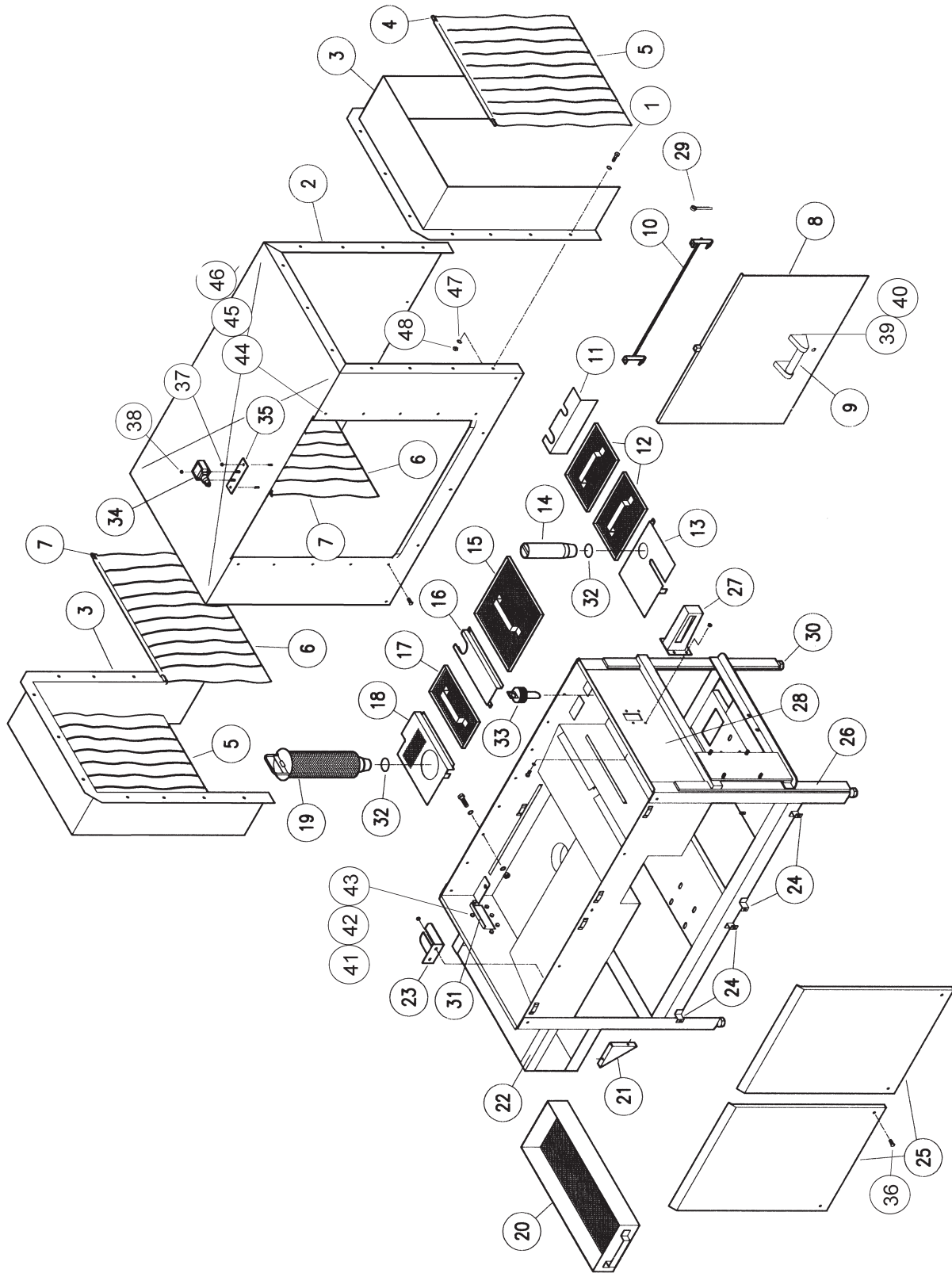

Cabinet Assembly

ADC-44 L-R Tall

Ref. No.	Part No.	No. Req.	Description
1	098-1423	9	Bolt, 1/4"-20 x 1/2" HH SS (Per End Shield)
2	285-6263	1	Hood Weldment, L- Tall
3	285-6265	2	Hood End Shield Weldment, Cowl Tall
N/S	285-6116	Opt. 2	Vent Weldment, Hood End Shield (4" Tall)
4	284-6122	2	Rod, Curtain 5/17" x 20.5" Long
5	299-1012	2	Curtain 21" Wide x 25" Tall (End Curtains)
6	299-1002	2	Curtain 23" Wide x 11" Tall
7	284-6121	2	Rod, Curtain 5/16" x 24" Lg
8	285-6266	1	Door Weldment Tall, Front Access, Less Handle
N/S	287-6223	2	Door Guide Tall, SS
9	285-6139	1	Handle Weldment, Front Access Door
10	285-6125	1	Latch Weldment, Door
11	285-6152	1	Cover Weldment, Rinse Float, L-R
12	285-6123	2	Screen Weldment, Rinse Tank (9-3/4" x 7")
13	286-6200	1	Plate, Rinse Stand Tube, L-R
14	281-6210	1	Drain Stand Tube, with O-Ring, Rinse Tank
15	285-6145	1	Screen Weldment, Wash Tank Large L-R (10-3/4" x 10-3/4")
16	286-6179	1	Cover, Wash Manifold
17	285-6122	1	Screen Weldment, Wash Small (10-3/4" x 5-3/8")
18	286-6197	1	Plate, Wash Pump Filter L-R
19	281-6211	1	Filter, Wash Pump with O-Ring
20	289-9109	1	Tray, Scrap Trap, Complete
21	289-9114	1	Support, Scrap Trap
22	289-9111	1	Scrap Trap (Box Only) L-R
23	286-6182	1	Guard, Wash Magnet
24	285-6151	4	Mount Weldment, Lower, Front Panel
25	285-6120	2	Panel Weldment, Front
26	285-6150	1	Frame Weldment, L-R
27	285-6119	1	Drip Chute Weldment
N/S	289-6601	1	Gasket, Drip Chute
28	285-6182	1	Pan Weldment, L-R
29	098-8008	2	Cotter Pin, 3/32" x 1" SS
30	099-1024	4	Bullet Feet, SS
31	285-6132	1	Spacer Weldment, Scrap Trap

Cabinet Assembly

ADC-44 L-R Tall

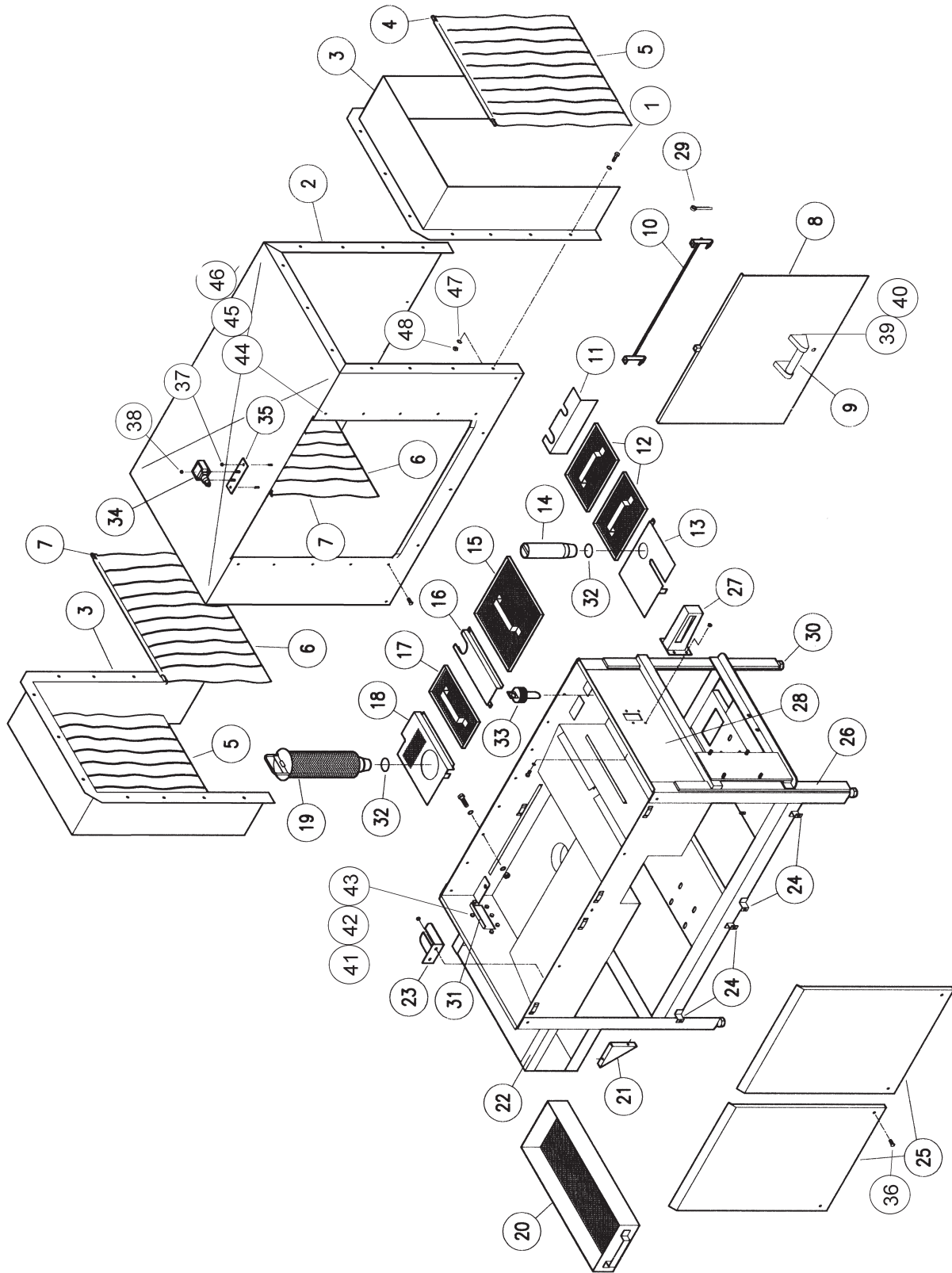

Cabinet Assembly

ADC-44 L-R Tall

Ref. No.	Part No.	No. Req.	Description
N/S	289-6623	2	Gasket, Scrap Trap Spacer, Teflon
32	289-6611	2	Gasket, 'O' Ring Wash/Rinse Taper
33	285-6162	1	Filter Screen Weldment, Rinse Pump
34	099-4502	1	Switch, Door Cut-Off
35	285-6103	1	Bracket, Door Cut-Off (Holds Switch)
N/S	285-6146	1	Cover, Transfer Chute Weldment L-R
36	098-1414	4	Bolt, 1/4"-20 x 1/2", TH, SS
37	098-2507	2	Locknut, 1/4"-20, SS
38	098-2301	2	Locknut, 10-32, SS
N/S	285-6258	Opt	Vent Weldment, 8"
N/S	285-6244	Opt	Vent Extension (Fits 4" x 16" Vents-16OA, Can be cut with a sawz-all)
N/S	289-9116	Rep	Scrap Accumulator, L-R Complete
N/S	288-1076	Tool	Kit, Pallet Removal
N/S	286-6276	Rep	Catch, Door Safety (Catch Only)
N/S	288-1065	Opt	Plug, Probe + Injection Hole (Two per Machine)
N/S	285-6275	1	Base, Door Safety Latch, Tall Conveyor
39	098-1414	4	Screw, 1/4"-20 x 1/2" TH, SS (Door Handle)
40	098-2416	4	Washer, 1/4" Flat, SS (Door Handle)
41	098-2507	10	Locknut, 1/4"-20 w/nylon Insert, SS (Scrap Trap)
42	098-1426	8	Bolt, 1/4"-20 x 3/4", HH, SS (Scrap Trap)
43	098-2416	8	Washer, 1/4" Flat, SS (Scrap Trap)
44	098-1414	4	Screw, 1/4"-20 x 1/2", TH, SS (Per Door Guide)
45	098-2507	4	Locknut, 1/4"-20 w/nylon Insert, SS (Per Door Guide)
46	098-2416	4	Washer, 1/4" Flat, SS (Per Door Guide)
47	098-2416	18	Washer, 1/4" Flat, SS (Per End Shield)
48	098-2507	9	Locknut, 1/4"-20 W/Nylon Insert (Per End Shield)

Cabinet Assembly

ADC-44 L-R Tall

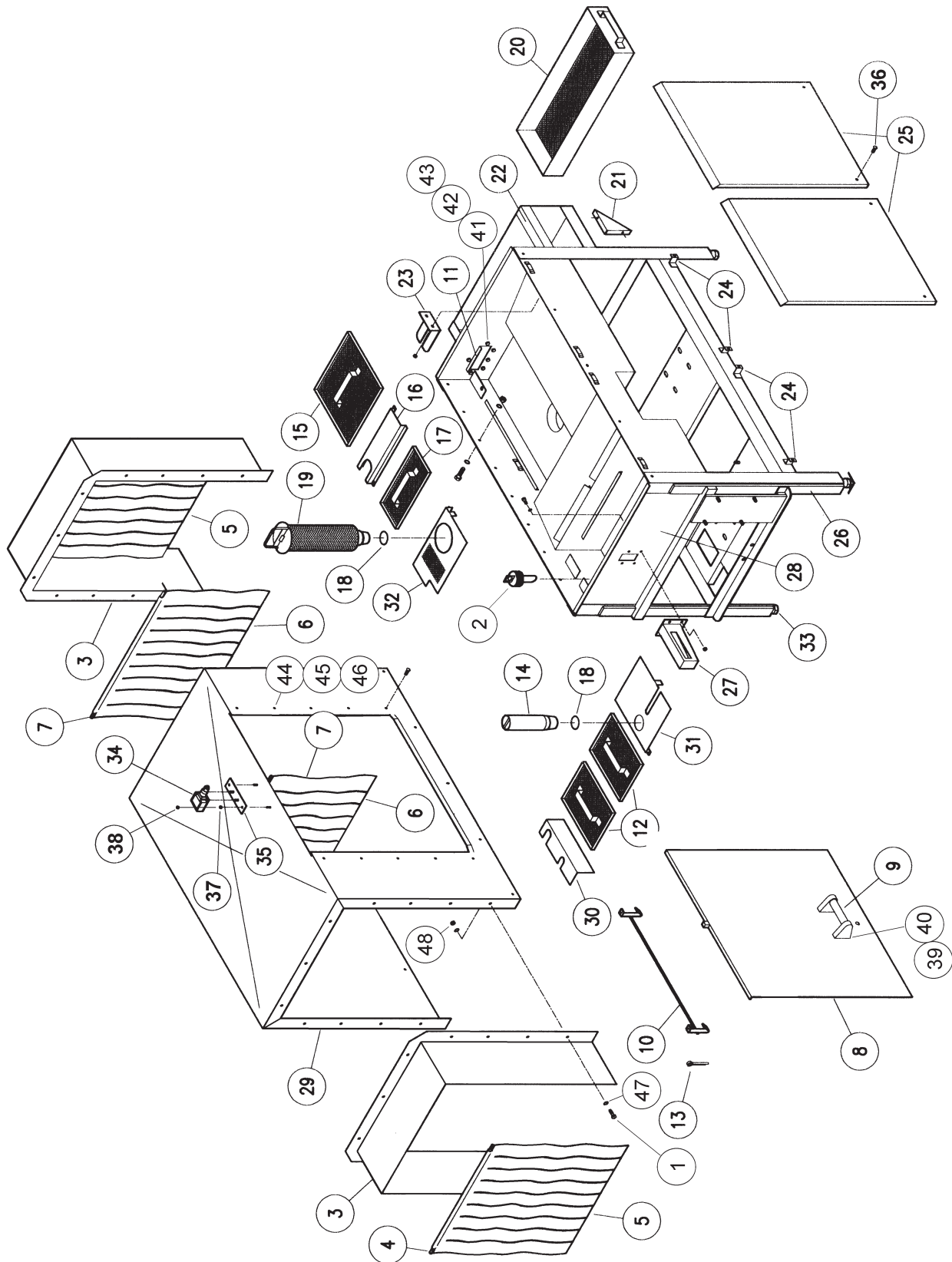

Cabinet Assembly

ADC-44 L-R Tall

Ref. No.	Part No.	No. Req.	Description
1	098-1423	9	Bolt, 1/4"-20 x 1/2" HH, SS (Per End Shield)
2	285-6162	1	Filter Screen Weldment, Rinse Pump
3	285-6265	2	Hood End Shield Weldment, Cowl Tall
N/S	285-6116	Opt-2	Vent Weldment, Hood End Shield (4" Tall)
4	284-6122	2	Rod, Curtain 5/16" x 20.5" Lg
5	299-1012	2	Curtain 21" Wide x 25" Tall (End Curtains)
6	299-1002	2	Curtain 23" Wide x 11" Tall
7	284-6121	2	Rod, Curtain 5/16" x 24" Lg
8	285-6266	1	Door Weldment Tall, Front Access Less Handle
N/S	287-6223	2	Door Guide Tall, SS
9	285-6139	1	Handle Weldment, Front Access Door
10	285-6125	1	Latch Weldment, Door
11	285-6132	1	Spacer Weldment, Scrap Trap
N/S	289-6623	2	Gasket, Scrap Trap Spacer, Teflon
12	285-6123	2	Screen, Weldment Tank, Rinse Tank (9-3/4" x 7")
13	098-8008	2	Cotter Pin, 3/32" x 1" SS
14	281-6210	1	Drain Stand Tube with O-Ring, Rinse Tank
15	285-6121	1	Screen Weldment, Wash R-L, Large (10-3/4" x 8-3/8")
16	286-6179	1	Cover, Wash Manifold
17	285-6122	1	Screen Weldment, Wash Small (10-3/4" x 5-3/8")
18	289-6611	2	Gasket, 'O' Ring Wash/Rinse Taper
19	281-6211	1	Filter, Wash Pump with O-Ring
20	289-9109	1	Tray, Scrap Trap, Complete
21	289-9114	1	Support, Scrap Trap
22	289-9110	1	Scrap Trap (Box Only), R-L
23	286-6182	1	Guard, Wash Magnet
24	285-6151	4	Front Panel Mount Weldment, Lower
25	285-6120	2	Panel Weldment, Front
26	285-6118	1	Frame Weldment, R-L
27	285-6119	1	Drip Chute Weldment
N/S	289-6601	1	Gasket, Drip Chute
28	285-6117	1	Pan Weldment, R-L With Wash Float Cover
29	285-6264	1	Hood Weldment Tall, R-L
30	285-6126	1	Cover Weldment, Rinse float, R-L

Cabinet Assembly

ADC-44 L-R Tall

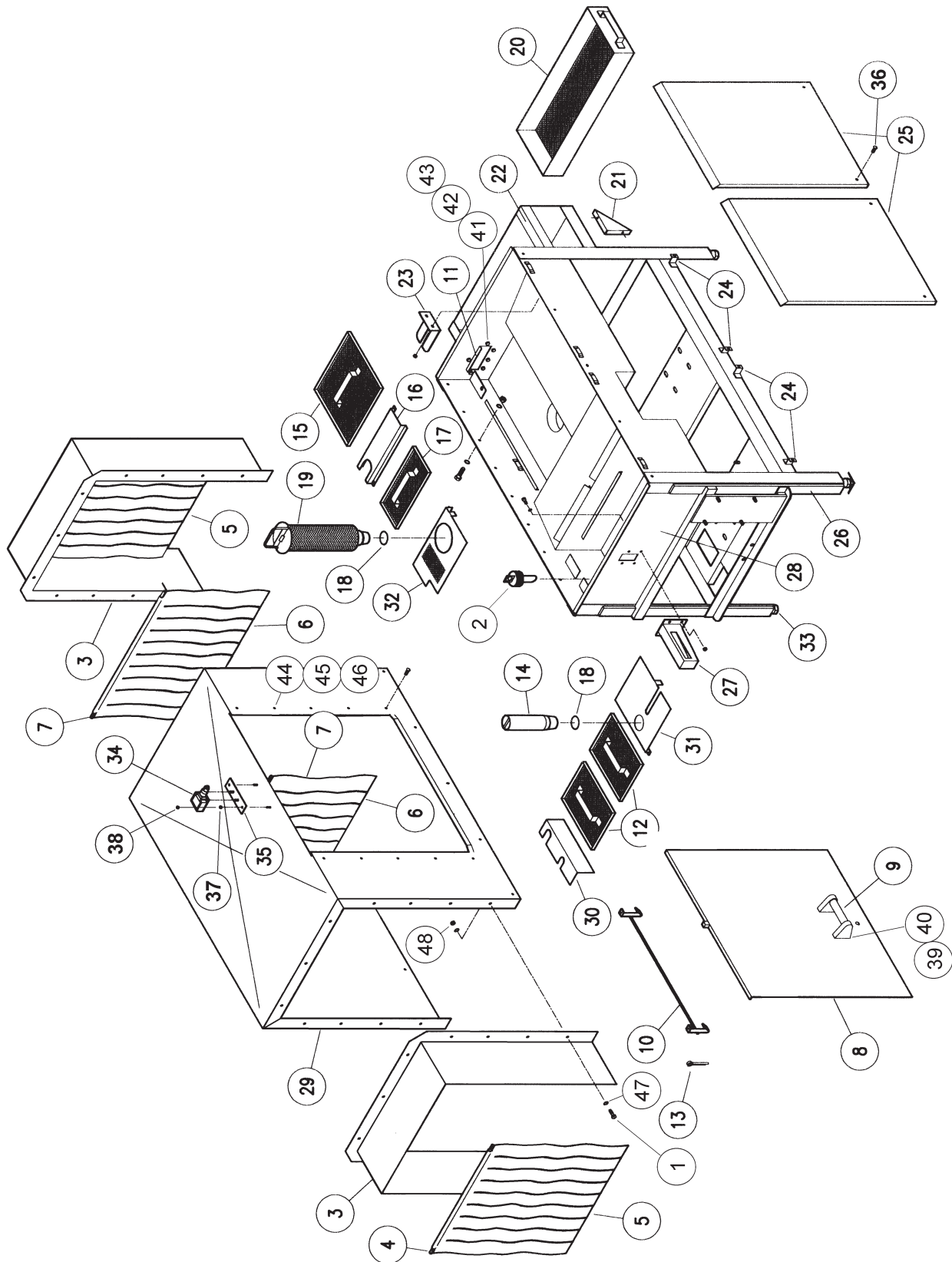

Cabinet Assembly

ADC-44 L-R Tall

Ref. No.	Part No.	No. Req.	Description
31	286-6176	1	Plate, Rinse Stand Tube, R-L
32	286-6174	1	Plate, Wash Pump Filter, R-L
33	099-1024	4	Bullet Feet, SS
34	099-4502	1	Switch, Door Cut-Off
35	285-6103	1	Bracket, Door Cut-Off, "Holds Switch"
N/S	285-6131	1	Cover, Transfer Chute, Weldment R-L
36	098-1414	4	Bolt, 1/4"-20 x 1/2", TH, SS
37	098-2507	2	Locknut, 1/4"-20, SS
38	098-2301	2	Locknut, 10-32, SS
N/S	286-6305	Rep	Cover, Float Bolt-On R-L
N/S	285-6258	Opt	Vent Weldment 8"
N/S	285-6244	Opt	Vent Extension (fits 4" x 16" Vents, 16" OA can be cut with a sawz-all)
N/S	289-9117	Rep	Scrap Accumulator, Complete R-L
N/S	285-6275	1	Base, Door Safety Latch, Tall Conveyor
N/S	286-6276	Rep	Catch, Door Safety (Catch Only)
N/S	288-1076	Tool	Kit, Pallet Removal
N/S	288-1065	Opt	Plug, Probe, & Injection Hole (2 Per Machine)
N/S	098-2308	2	Wingnut, 1/4"-20, Lock (For Float Cover)
39	098-1414	4	Screw, 1/4"-20 x 1/2" TH, SS (Door Handle)
40	098-2416	4	Washer, 1/4" Flat, SS (Door Handle)
41	098-2507	10	Locknut With Nylon Insert, SS (Scrap Trap)
42	098-1426	8	Bolt, 1/4"-20 x 3/4" HH, SS (Scrap Trap)
43	098-2416	8	Washer, 1/4" Flat, SS (Scrap Trap)
44	098-1414	4	Screw, 1/4"-20 x 1/2" TH, SS (Per Door Guide)
45	098-2507	4	Locknut With Nylon Insert, SS (Per Door Guide)
46	098-2416	4	Washer, 1/4" Flat, SS (Per Door Guide)
47	098-2416	18	Washer, 1/4" Flat, SS (Per End Shield)
48	098-2507	9	Locknut With Nylon Insert, SS (Per End Shield)

Conveyor Drive & Tray Track Control

ADC-44 L-R Tall

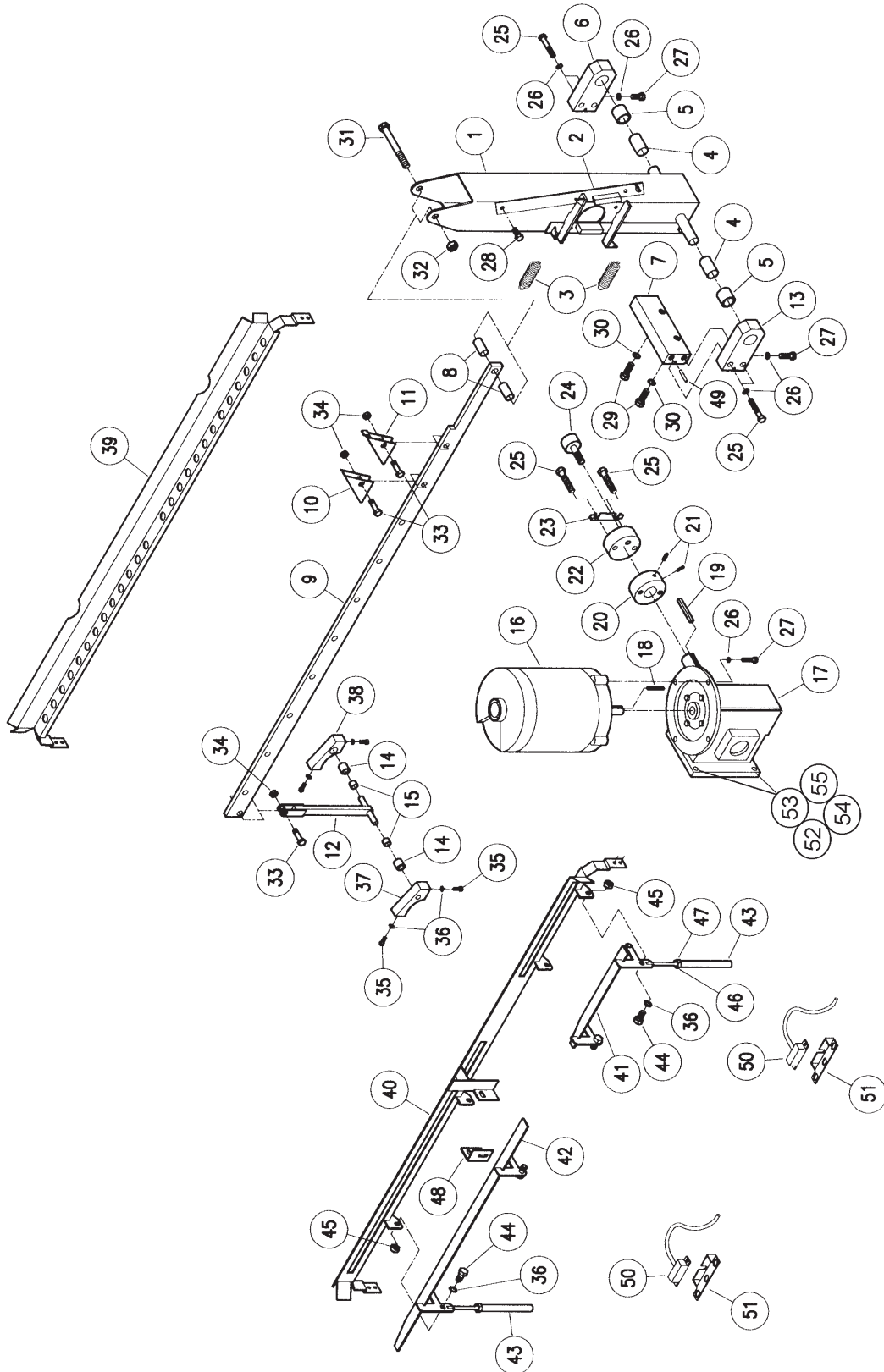

Conveyor Drive & Tray Track Control

ADC-44 L-R Tall

Ref. No.	Part No.	No. Req.	Description
1	285-6133	1	Rocker Arm Weldment
2	285-6134	2	Slip Clutch Bar Weldment (Rubbing Block)
3	298-3001	2	Spring, Slip Clutch
4	284-6142	2	Spacer, Rocker Arm
5	298-4001	2	Bushing, Rocker Arm, 1" OD x 3/4" ID x 7/8" Lg
6	284-6141	1	Block, Pillow Bushing, RH
7	284-6139	1	Block, Base, Pillow Bushing
8	284-6149	2	Spacer, Conveyor Connecting Bolt
9	284-6138	1	Bar, Conveyor, Approximately 47" Long, Less Dogs
N/S	284-6187	Opt.	Bar, Side Loader Conv., Approx, 69" Long, Less Dogs
N/S	285-6187	Opt.	Guide Weldment, Side Loader Bar, "Rubbing Block"
10	285-6136	6	Dog Weldment, Conveyor
11	285-6137	4	Exit Dog Weldment, Conveyor
N/S	285-6138	Opt.	Side Loader Dog Weldment, Conveyor
12	285-6135	1	Idler Arm Weldment
13	284-6140	1	Block, Pillow Bushing LH
14	298-4002	2	Bushing, Idler Arm, 5/8" OD x 3/8" ID x 5/8" Lg
15	284-6143	2	Spacer, Idler Arm, 5/8" OD x 3/8" ID x 3/8" Lg
16	291-1003	1	Motor 1/3 HP, 3PH
N/S	291-1007	Opt.	Motor 1/3 HP, 1PH
N/S	299-1008	1	Cover, Conveyor Drive Motor w/Screws
17	291-1004	1	Gear Box (53:1) (Reducer)
18	284-6201	1	Key, Conveyor Drive Motor
19	284-6137	1	Key, Cam Block (For Cam Block A)
20	284-6134	1	Cam Block (A) Gear Box Side
21	098-1441	2	Screw, Set, 1/4"-20 x 1/2" Lg (For Cam Block A)
22	284-6135	1	Cam Block (B) Cam Follower Side
23	286-6189	1	Bolt Lock, Cam Follower
24	281-6201	1	Bearing, Cam Follower
25	098-1611	6	Bolt, 3/8"-16 x 2 Lg, HH, SS
26	098-2710	10	Washer, 3/8", Split, SS
27	098-1614	6	Bolt, 3/8" x 1", HH, SS
28	098-1506	2	Bolt, 5/16"-18 x 3/4" Lg, HH, SS
29	098-1802	2	Bolt, 1/2"-13 x 1-1/4" Lg, HH, SS
30	098-2802	2	Washer, 1/2", Split, SS

Conveyor Drive & Tray Track Control

ADC-44 L-R Tall

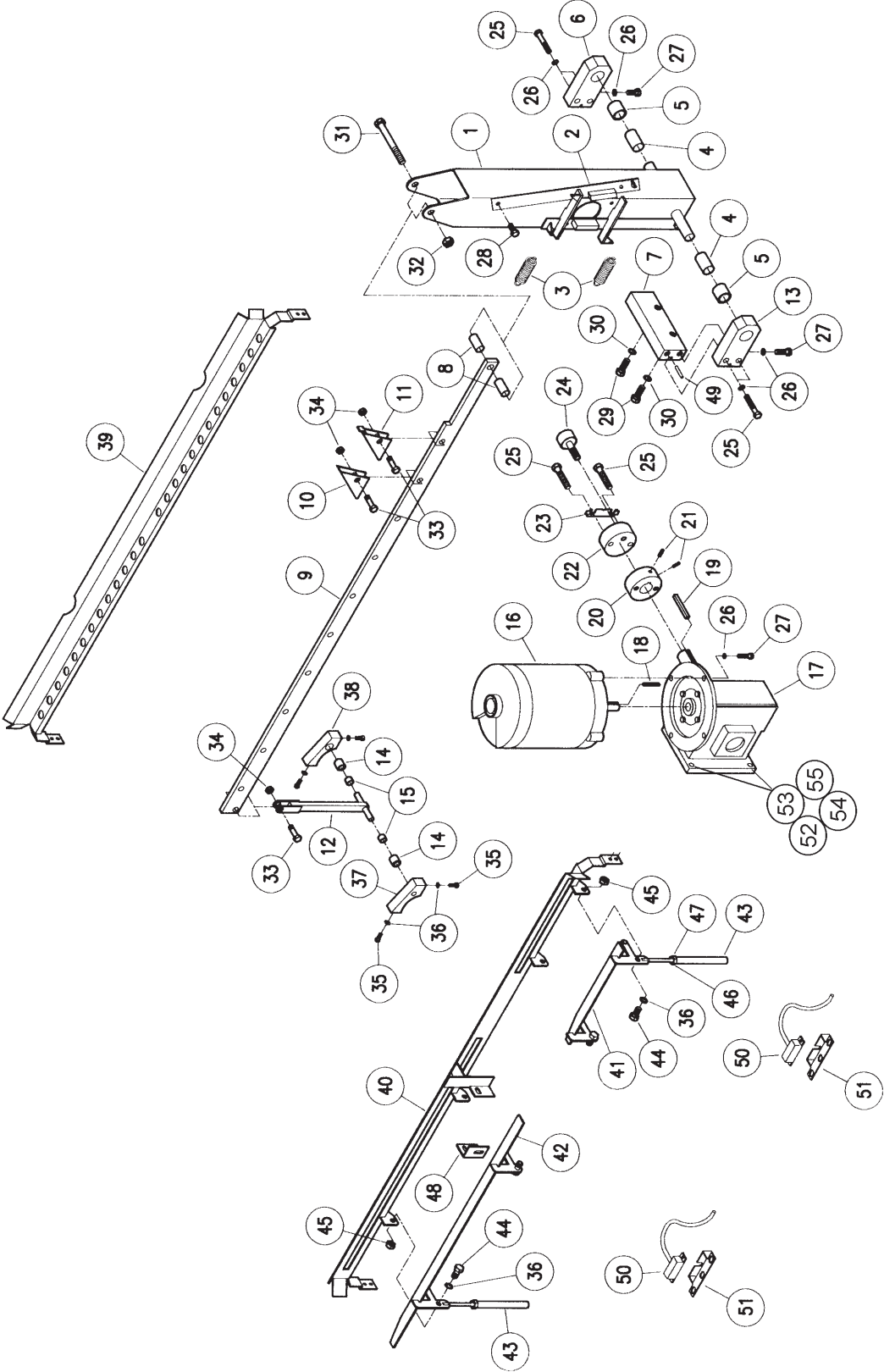

Conveyor Drive & Tray Track Control

ADC-44 L-R Tall

Ref. No.	Part No.	No. Req.	Description
31	098-1801	1	Bolt, 1/2"-13 x 4" Lg, HH, SS
32	098-2801	1	Locknut, 1/2"-13
33	098-1612	11	Dog Bolt, 3/8"-16 x 1-1/8" with 3/4" Shoulder
34	098-2708	11	Locknut, 3/8"-16 SS
35	098-1424	4	Bolt, 1/4"-20 x 3/8" Lg, HH, SS
36	098-2416	12	Washer, 1/4", SS
37	284-6130	1	Bushing Mount, Idler Arm (A) L-R
38	284-6131	1	Bushing Mount, Idler Arm (B) L-R
39	285-6113	1	Tray Track Weldment, Rear, L-R & R-L
40	285-6112	1	Tray Track Weldment, Front L-R
41	285-6108	1	Tray Track Sequence Bar Weldment, Rinse L-R
42	285-6107	1	Tray Track Sequence Bar Weldment, Wash L-R
43	285-6109	2	Magnet Weldment, Tray Track Sequence Bar
44	098-1428	4	Bolt, 1/4"-20 x 1-1/8" Lg , HH, SS
45	098-2507	4	Locknut, 1/4"-20, SS, W/Nylon Insert
46	098-2506	2	Washer, 5/16" Split, SS
47	098-2502	2	Nut, 5/16"-18, SS
48	286-6178	2	Bracket, Tray Track Mount
49	098-8009	2	Dowel Pin 3/16" x 1" Lg, SS
50	291-3011	2	Switch, Reed
51	286-6113	2	Bracket, Reed Switch
52	098-1438	2	Bolt, 3/8"-16 x 1-1/4" Lg, HH, SS (For Gear Box)
53	098-2708	2	Locknut, 3/8"-16, SS (For Gear Box)
54	098-2710	2	Lockwasher, 3/8", Split, SS (For Gear Box)
55	098-1614	2	Bolt, 3/8"-16 x 1" Lg, HH, SS (For Gear Box)
N/S	288-1047	Rep	Conveyor Drive Motor and Gear Box Assembly, 3 Ph
N/S	288-1053	Tool	Tool, Conveyor Clutch Spring
N/S	288-1072	Rep	Conveyor Drive motor and Gear Box Assembly, 1 Ph

Conveyor Drive & Tray Track Control

ADC-44 L-R Tall

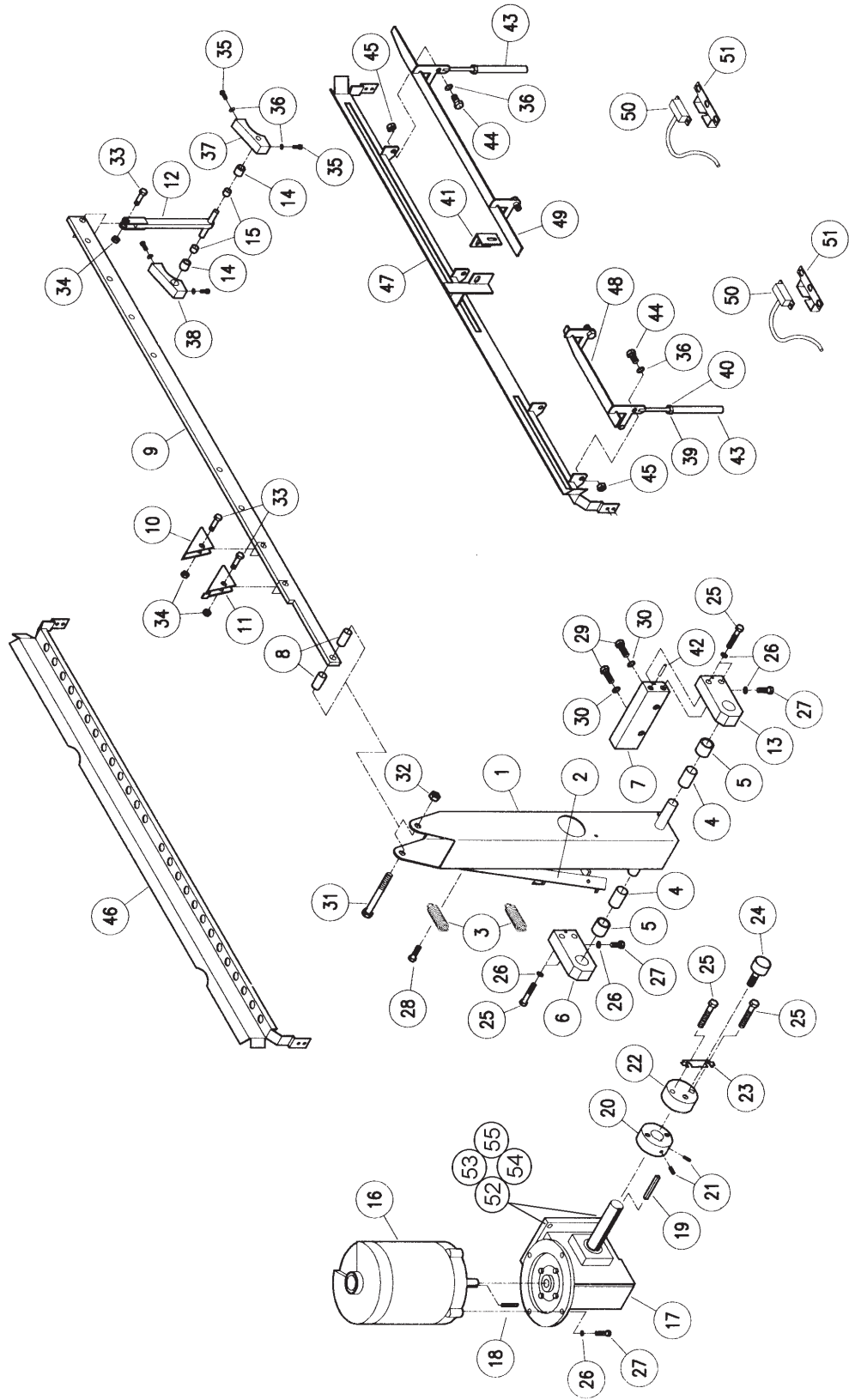

Conveyor Drive & Tray Track Control

ADC-44 L-R Tall

Ref. No.	Part No.	No. Req.	Description
1	285-6133	1	Rocker Arm Weldment
2	285-6134	2	Slip Clutch Bar Weldment (Rubbing Block)
3	298-3001	2	Spring, Slip Clutch
4	284-6142	2	Spacer, Rocker Arm
5	298-4001	2	Bushing, Rocker Arm, 1" OD x 3/4" ID x 7/8" Lg
6	284-6140	1	Block, Pillow Bushing, LH
7	284-6139	1	Block, Base, Pillow Bushing
8	284-6149	2	Spacer, Conveyor Connecting Bolt
9	284-6138	1	Bar, Conveyor, Approximately 47" Long, Less Dogs
N/S	284-6187	Opt.	Bar, Side Loader Conv., Approx. 69" Long, Less Dogs
N/S	285-6187	Opt.	Guide Weldment, Side Loader Bar, "Rubbing Block"
10	285-6136	6	Dog Weldment, Conveyor
11	285-6137	4	Exit Dog Weldment, Conveyor
N/S	285-6138	Opt.	Side Loader Dog Weldment, Conveyor
12	285-6135	1	Idler Arm Weldment
13	284-6141	1	Block, Pillow Bushing RH
14	298-4002	2	Bushing, Idler Arm, 5/8" OD x 3/8" ID x 5/8" Lg
15	284-6143	2	Spacer, Idler Arm, 5/8" OD x 3/8" ID x 3/8" Lg
16	291-1003	1	Motor 1/3 HP, 3PH
N/S	291-1007	Opt.	Motor 1/3 HP, 1PH
N/S	299-1008	1	Cover, Conveyor Drive Motor w/Screws
17	291-1004	1	Gear Box (53:1) (Reducer)
18	284-6201	1	Key, Conveyor Drive Motor
19	284-6137	1	Key, Cam Block (For Cam Block A)
20	284-6134	1	Cam Block (A) Gear Box Side
21	098-1441	2	Screw, Set, 1/4"-20 x 1/2" Lg (For Cam Block A)
22	284-6135	1	Cam Block (B) Cam Follower Side
23	286-6189	1	Bolt Lock, Cam Follower
24	281-6201	1	Bearing, Cam Follower
25	098-1611	6	Bolt, 3/8"-16 x 2" Lg, HH, SS
26	098-2710	10	Washer, 3/8", Split, SS
27	098-1614	6	Bolt, 3/8" x 1", HH, SS
28	098-1506	2	Bolt, 5/16"-18 x 3/4" Lg, HH, SS
29	098-1802	2	Bolt, 1/2"-13 x 1-1/4" Lg, HH, SS
30	098-2802	2	Washer, 1/2", Split, SS

Conveyor Drive & Tray Track Control

ADC-44 L-R Tall

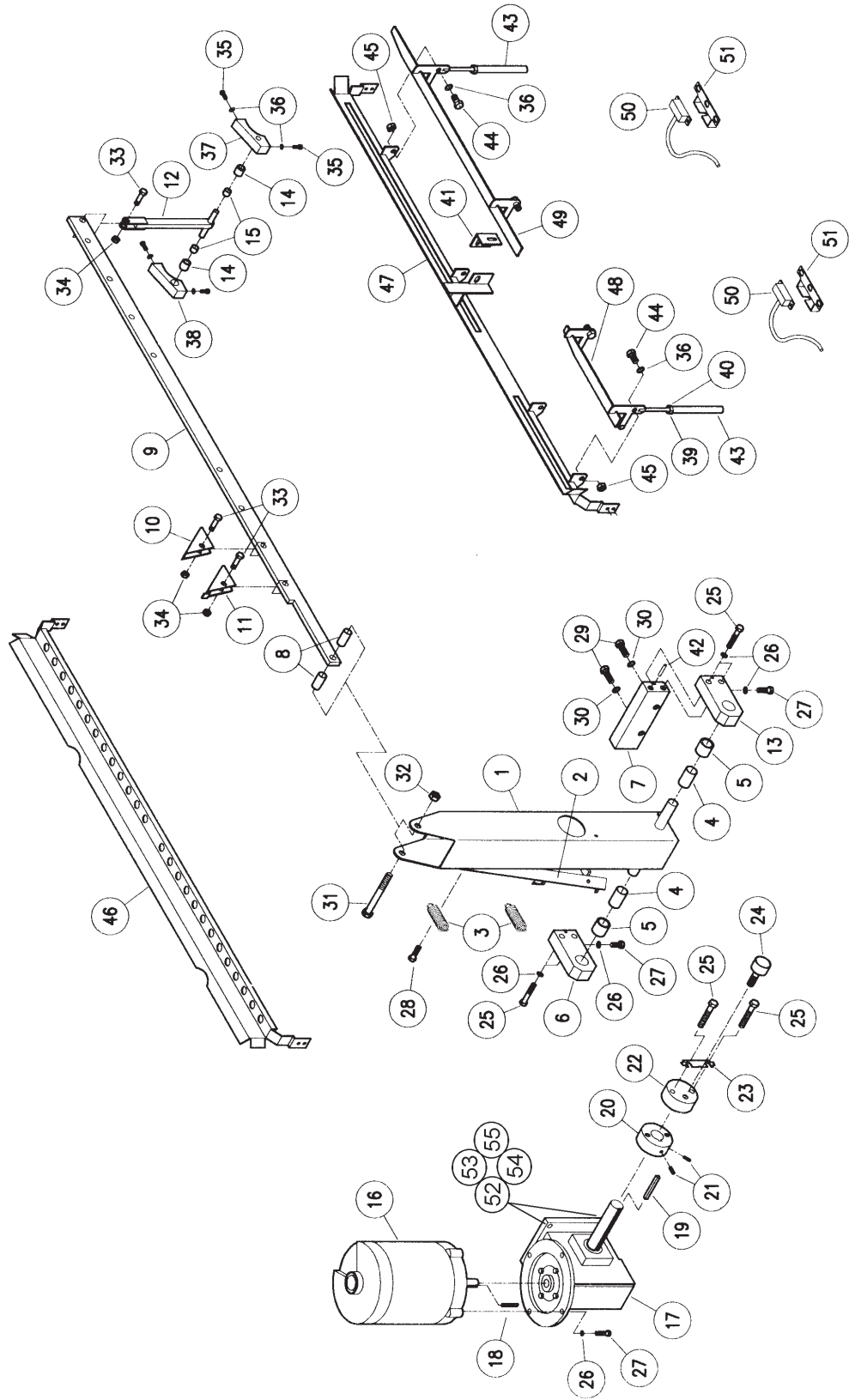

Conveyor Drive & Tray Track Control

ADC-44 L-R Tall

Ref. No.	Part No.	No. Req.	Description
31	098-1801	1	Bolt, 1/2"-13 x 4" Lg, HH, SS
32	098-2801	1	Locknut, 1/2"-13
33	098-1612	11	Dog Bolt, 3/8"-16 x 1-1/8" with 3/4" Shoulder
34	098-2708	11	Locknut, 3/8"-16 SS
35	098-1424	4	Bolt, 1/4"-20 x 3/8" Lg, HH, SS
36	098-2416	12	Washer, 1/4", SS
37	284-6132	1	Bushing Mount, Idler Arm (C) R-L
38	284-6133	1	Bushing Mount, Idler Arm (D) R-L
39	098-2506	2	Washer, 5/16" Split, SS
40	098-2502	2	Nut, 5/16"-18, SS
41	286-6178	2	Bracket, Tray Track Mount
42	098-8009	2	Dowel Pin 3/16" x 1" Lg, SS
43	285-6109	2	Magnet Weldment, Tray Track Sequence Bar
44	098-1428	4	Bolt, 1/4"-20 x 1-1/8" Lg, HH, SS
45	098-2507	4	Locknut, 1/4"-20, SS, W/Nylon Insert
46	285-6113	1	Tray Track Weldment, Rear, L-R & R-L
47	285-6110	1	Tray Track Weldment, Front R-L
48	285-6106	1	Tray Track Sequence Bar Weldment, Rinse R-L
49	285-6105	1	Tray Track Sequence Bar Weldment, Wash R-L
50	291-3011	2	Switch, Reed
51	286-6113	2	Bracket, Reed Switch
52	098-1438	2	Bolt, 3/8"-16 x 1-1/4" Lg, HH, SS (For Gear Box)
53	098-2708	2	Locknut, 3/8"-16, SS (For Gear Box)
54	098-2710	2	Lockwasher, 3/8", Split, SS (For Gear Box)
55	098-1614	2	Bolt, 3/8"-16 x 1" Lg, HH, SS (For Gear Box)
N/S	288-1047	Rep	Conveyor Drive Motor and Gear Box Assembly, 3 Ph
N/S	288-1053	Tool	Tool, Conveyor Clutch Spring
N/S	288-1072	Rep	Conveyor Drive motor and Gear Box Assembly, 1 Ph

Spray System Assemblies

ADC-44 L-R Tall

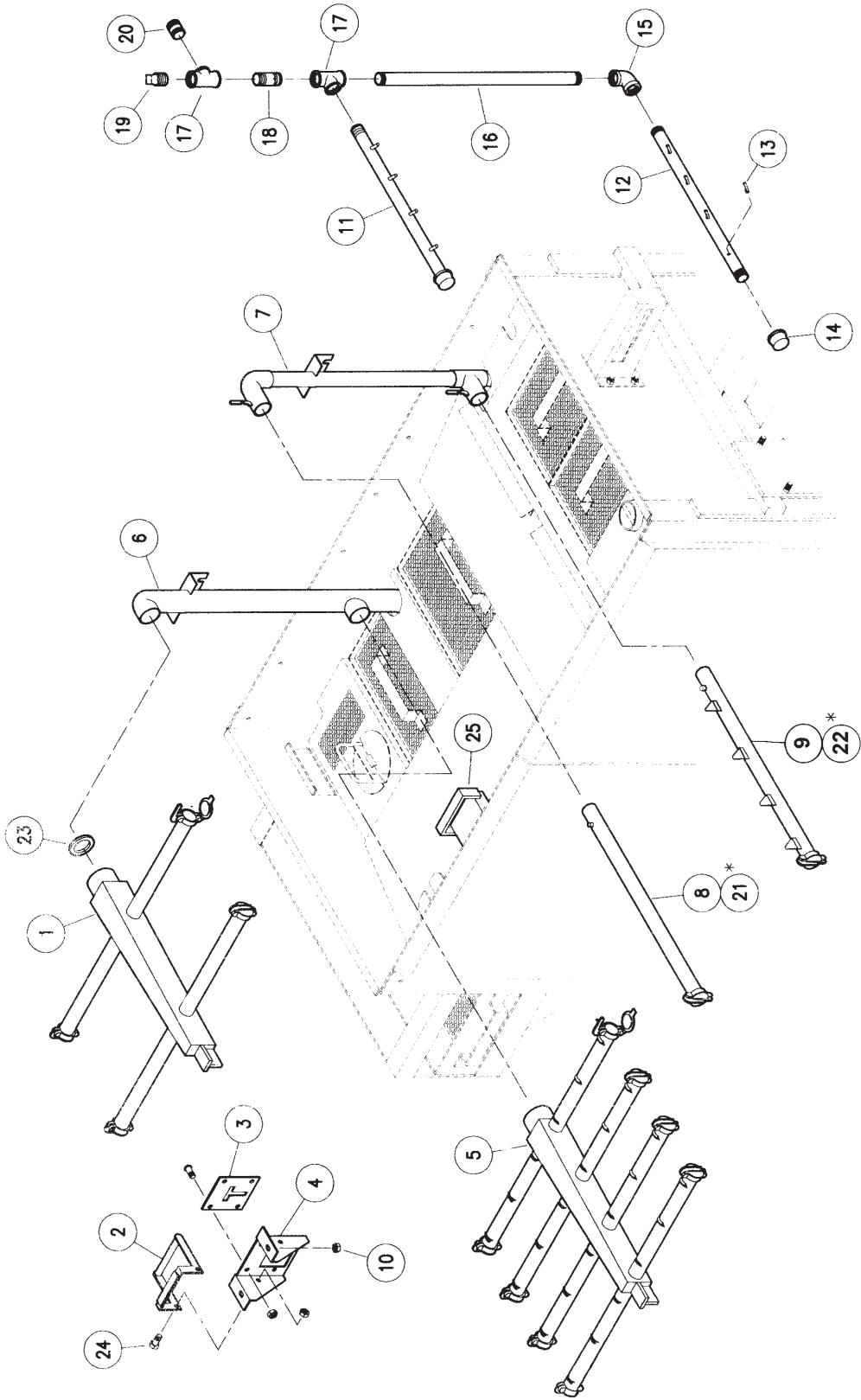

Spray System Assemblies

ADC-44 L-R Tall

Ref. No.	Part No.	No. Req.	Description
1	285-6159	1	Upper Wash Arm Weldment Assembly
2	285-6129	1	Handle Weldment, Upper Wash Arm Mount
3	285-6128	1	Tee Plate Weldment, Upper Wash Arm
4	286-6177	1	Bracket, Upper Wash Arm Mount
5	285-6156	1	Lower Wash Arm Weldment Assembly
6	285-6268	1	Manifold Weldment, Inside Wash Tall
7	285-6269	1	Manifold Weldment, Inside Pumped Rinse Tall
8	285-6168	1	Spray Arm Weldment, Pumped Rinse Upper, L-R
9	285-6167	1	Spray Arm Weldment, Pumped Rinse Lower, L-R
10	098-2507	8	Locknut, 1/4"-20, SS
N/S	285-6158	14	Spray Arm Endcap Weldment (Welded to Arm)
11A	281-6208	1	Spray Arm, Final Rinse, Upper, L-R, SS Jets
11B	281-6206		Spray Arm, Final Rinse, Upper, L-R, Poly Jets
11C	281-6204		Spray Arm, Final Rinse, Upper, R-L, SS Jets
11D	281-6202		Spray Arm, Final Rinse, Upper, R-L, Poly Jets
12A	281-6209	1	Spray Arm, Final Rinse, Lower, L-R, SS Jets
12B	281-6207		Spray Arm, Final Rinse, Lower, L-R, Poly Jets
12C	281-6205		Spray Arm, Final Rinse, Lower, R-L, SS Jets
12D	281-6203		Spray Arm, Final Rinse, Lower, R-L, Poly Jets
13A	284-6146	8	Jets, Final Rinse Spray Arm, SS
13B	284-6145		Jets, Final Rinse Spray Arm, Poly
14	292-1011	2	Cap, 1/2" FPT, SS
15	292-1003	1	Fitting, 1/2" FPT, 90° Elbow, SS
16	292-3016	1	Nipple, 1/2" x 27.625" Lg, SS
17	292-1002	2	Fitting, 1/2" x 1/2" x 1/2" Tee, SS
18	292-3010	1	Nipple, 1/2" x 3" SS
19	292-1012	1	Plug, 1/2" MPT, SS
20	292-3014	1	Nipple, 1/2" x 2" Lg, SS
21	285-6170		Spray Arm, Pumped Rinse, Upper, R-L
22	285-6169		Spray Arm, Pumped Rinse, Lower, R-L

Spray System Assemblies

ADC-44 L-R Tall

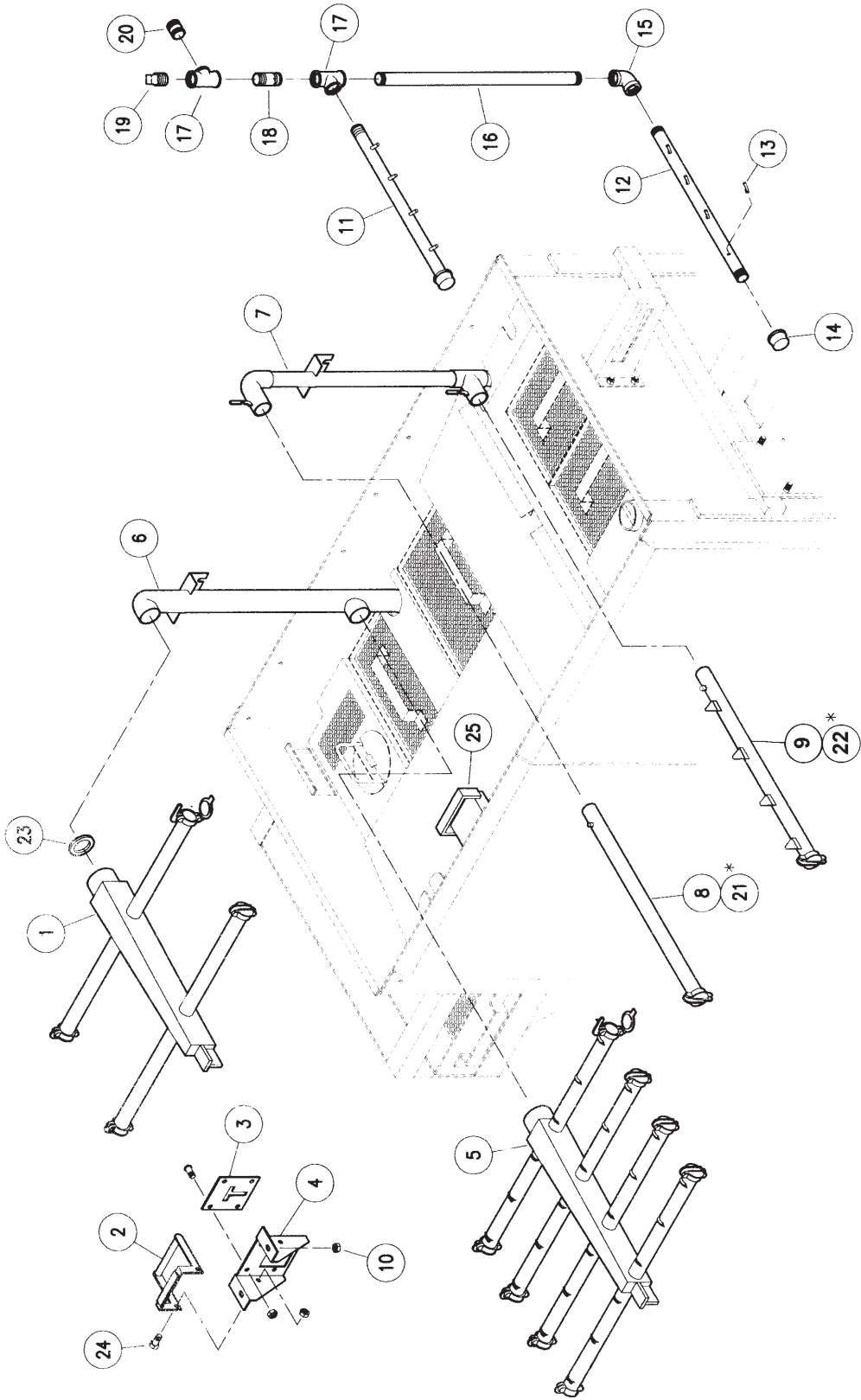

Wash Pump Assembly

ADC-44 L-R Tall

Ref. No.	Part No.	No. Req.	Description
1	291-1002	1	Motor, 3HP, 3 Phase w/Sleeve
	291-1006		Motor, 3HP, 1 Phase w/Sleeve
2	282-6301	1	Housing, Rear, Wash
3	289-6621	1	Gasket, Sump, Teflon
4	289-6606	1	Gasket, O-Ring, Drain Socket Flange
5	284-6203	1	Sleeve, Wash Pump Shaft
6	292-2001	1	Seal, Wash Pump
7	289-6603	1	Gasket, Wash Pump O-Ring
8	282-6303	1	Impeller, Wash Pump
9	284-6151	1	Key, Wash Pump Impeller
10	098-1613	1	Bolt, 3/8"-16 x 1" Lg, HH, SS, w/Lock Strip
11	098-2711	1	Washer, 3/8" ID x 1" OD x .103 Thick, SS
12	282-6302	1	Cover, Wash Pump
13	289-6604	1	Gasket, Wash Pump Discharge Flange
14	285-6153	1	Discharge Tube Weldment, Wash Pump
15	289-6605	1	Gasket, Wash Pump Intake Flange
16	285-6154	1	Intake Tube, Sump Weldment, Wash Pump
17	285-6157	1	Drain Socket Weldment, Wash
18	289-6622	2	Gasket, Wash Tank Flange, Teflon
19	092-1158	1	Plug, 1/4" MPT, HH
20	098-1423	6	Bolt, 1/4"-20 x 1/2" Lg, HH, SS
21	098-2416	6	Washer, 1/4" SS
22	098-1614	16	Bolt, 3/8"-16 x 1" Lg, HH, SS
23	098-2711	8	Washer, 3/8" ID x 1" OD x .103 Thick, SS
24	098-1510	4	Bolt, 5/16"-18 x 1-1/4" Lg, HH, SS
25	098-2509	8	Washer, 5/16", SS
26	098-2710	8	Washer, 3/8" Split, SS
27	098-1502	4	Bolt, 5/16"-18 x 1/2", HH, SS
N/S	288-1048	Rep	Pump Assy. Less Cover, Wash, 3HP, 3 Phase
N/S	288-1056	Rep	Pump Assy. Less Cover, Wash, 3HP, 1 Phase
28	289-6618	2	O-Ring, Wash Pump Shaft Sleeve
N/S	098-2510	4	Washer, 5/16" SS Neobond (For Inside of Pump Discharge)

Rinse Pump Assembly

ADC-44 L-R Tall

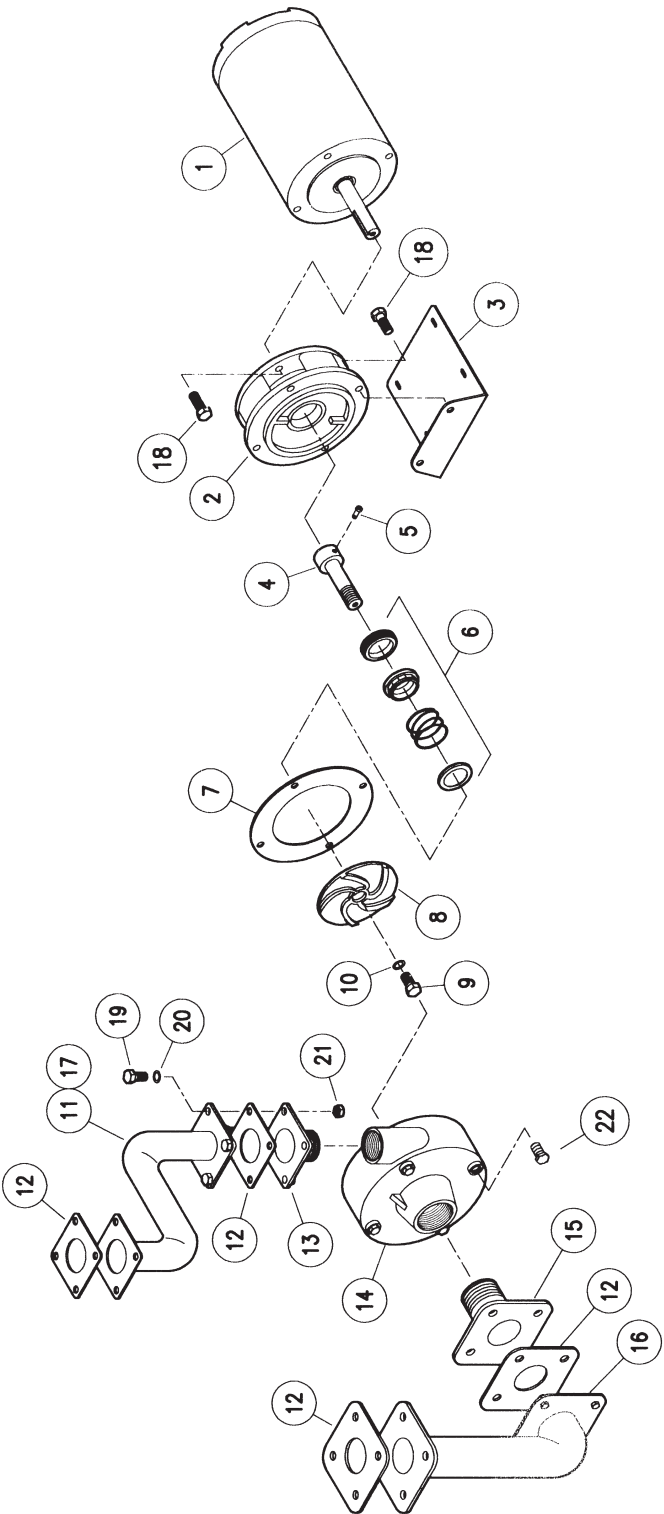

Rinse Pump Assembly

ADC-44 L-R Tall

Ref. No.	Part No.	No. Req.	Description
1	291-1003	1	Motor, 1/3 HP, 3 Phase
	291-1007		Motor, 1/3 HP, 1 Phase
2	282-6307	1	Housing, Pumped Rinse Rear
3	286-6250	1	Plate, Pump Rinse Motor Support, w/Pad
4	284-6163	1	Pump Shaft, Pumped Rinse, Auxiliary
5	098-1442	2	Set Screw, 1/4"-20 x 3/8" Lg, Rinse Pump Shaft
6	292-2002	1	Seal, Pumped Rinse Pump
7	289-6609	1	Gasket, Pumped Rinse Pump
8	282-6308	1	Impeller, Pumped Rinse Pump
9	098-1443	1	Bolt, 1/4"-28 x 3/8" Lg HH, SS
10	098-2413	1	Washer, 285 ID x .625 OD x .086 Thick, SS
11	285-6164	1	Discharge Tube Weldment L-R
12	289-6624	4	Gasket, Pumped Rinse Pump Flange, Teflon
13	285-6165	1	Discharge Flange Assembly Weldment
14	282-6306	1	Cover, Pumped Rinse Pump
15	285-6161	1	Intake Flange Weldment Assembly
16	285-6160	1	Intake Tube Weldment
17	285-6163	1	Discharge Tube Weldment R-L
18	098-1607	8	Bolt, 3/8"-16 x 7/8" HH, SS
19	098-1426	16	Bolt, 1/4"-20 x 3/4" HH, SS
20	098-2416	32	Washer, 1/4", SS
21	098-2507	16	Locknut, 1/4"-20, SS, W/Nylon Insert
22	092-1158	1	Plug, 1/4" MPT, SS
N/S	288-1040	Rep	Kit, Rinse Pump Seal (Includes Ref # 6, 7, 9 & 10)
N/S	288-1049	Rep	Pump Assy. Less Cover, Rinse, 1/3HP, 3 Phase
N/S	288-1061	Rep	Pump Assy. Less Cover, Rinse, 1/3HP, 1 Phase

Control System Assembly

ADC-44 L-R Tall

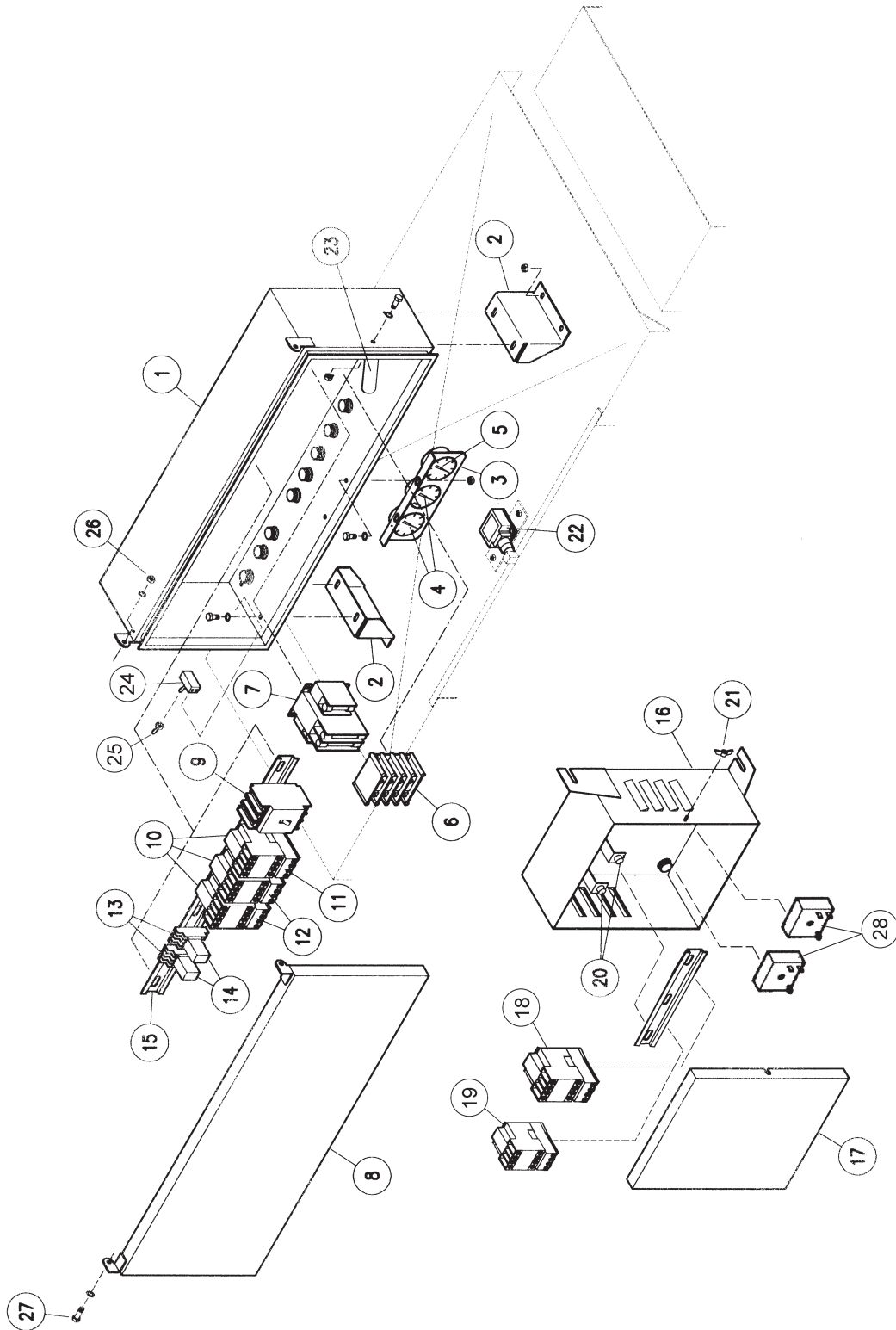

Control System Assembly

ADC-44 L-R Tall

Ref. No.	Part No.	No. Req.	Description
1	285-6101	1	Control Box Weldment
2	285-6293	2	Control Box Mounts
3	286-6180	1	Bracket, Temperature Gauge
4	299-1005	2	Gauge, Temperature, Wash & Rinse Tank (6' Capillary)
5	299-1004	1	Gauge, Temperature, Final Rinse (3' Capillary)
6A	291-5101	1	Terminal Block (Main 4 Pole)
6B	391-5105	Opt.	Terminal Block (Main 2 Pole Single Phase)
7	291-3004	1	Transformer w/Jumper Wires
N/S	291-9101	2	Fuse, 3 amp, Primary
N/S	291-9102	1	Fuse, 1 6/10 amp, Secondary
8	285-6102	1	Cover Weldment, Control Box
9A	291-3010	1	Circuit Breaker, 50 amp, 3 Pole, Three Phase
9B	391-3003	Opt.	Circuit Breaker, 20 amp, 2 Pole, Single Phase Rinse
9C	391-3004	Opt.	Circuit Breaker, 60 amp, 2 Pole, Single Phase Wash
10	291-3001	3	Contactor, 110 Volt
11A	291-3002	1	Overload, 3HP, 3 Phase
11B	291-3017	Opt.	Overload, 3HP, 1 Phase
12A	291-3003	2	Overload, 1/3HP, 3 Phase
12B	291-3018	Opt.	Overload, 1/3HP, 1 Phase
13	291-3009	3	Socket, Relay
14	291-3005	3	Relay, 110V, Double Pole
15	291-9104	1	Din Rail, 18" Lg
16	285-6104	1	Power Box Weldment, L-R
16B	285-6238	1	Power Box Weldment, R-L
17	285-6294	1	Cover, Power Box
18	291-3032	1	Contactor, Wash Heater, 110 Volt
19	291-3001	1	Contactor, Rinse Heater, 110 Volt
20	091-7006	2	Light, Heater, 110 Volt
21	098-2308	2	Wingnut, 1/4"-20, SS
22	099-4502	1	Switch, Door Cut-Off
23	284-6101	1	Bar, Control Box Safety
24	091-3008	1	Switch, Master
25	291-9105	1	Boot, Master Switch Cover
N/S	291-7101	1	Light, Indicator, 110 Volt

Control System Assembly

ADC-44 L-R Tall

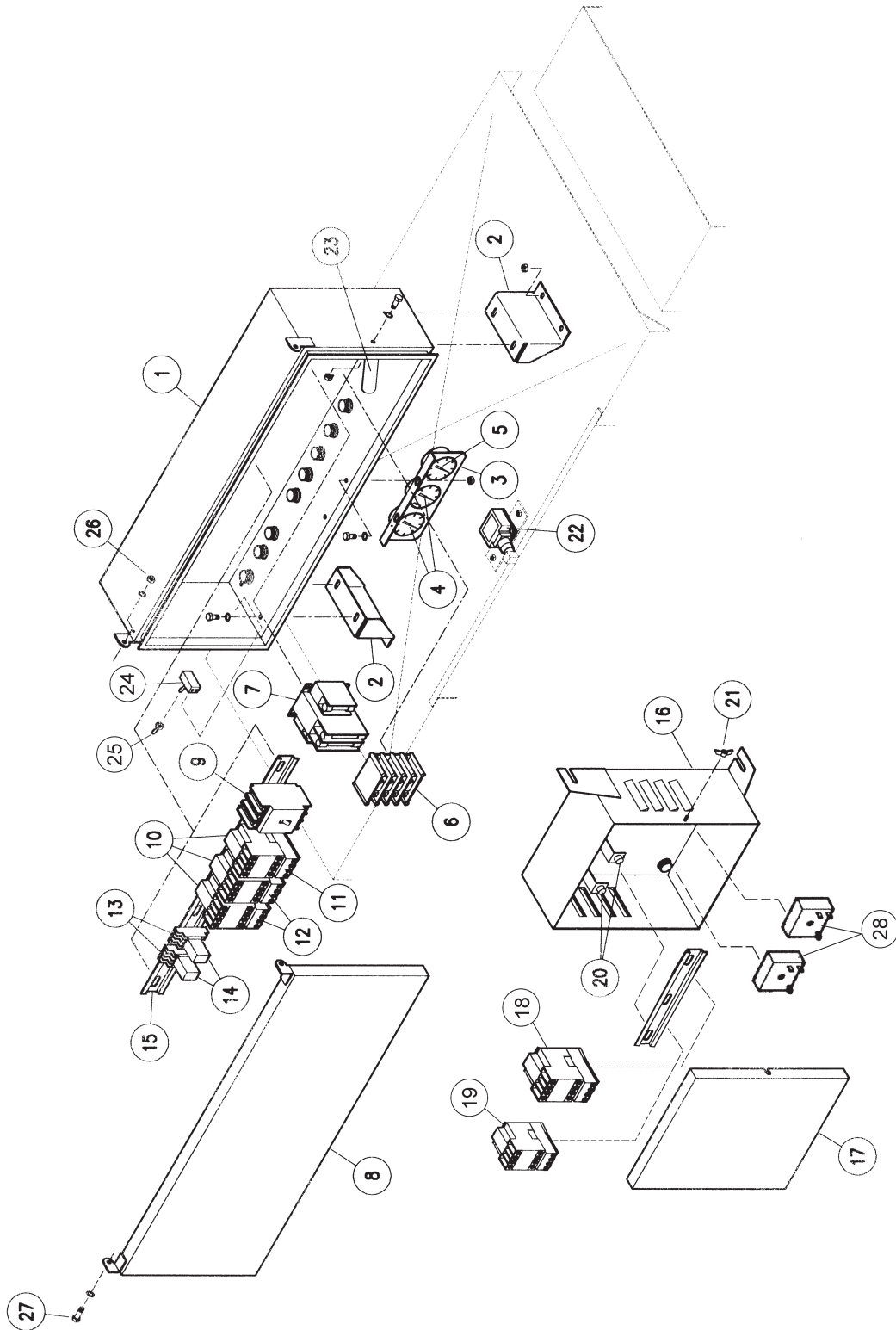

Control System Assembly

ADC-44 L-R Tall

Ref. No.	Part No.	No. Req.	Description
26	098-2507	13	Locknut, 1/4"-20 W/nylon insert, SS
27	098-1423	2	Bolt, 1/4"-20 x 1/2" HH, SS
28	291-3027	2	Relay, Heater Contactor Delay, 110 Volt
N/S	291-5103	1	Wire Harness, 3 Phase
N/S	291-3011	2	Switch, Reed
N/S	291-5102	1	Ground Lug
N/S	286-6107	1	Plate, 110v Terminal Block
N/S	291-5104	2	Block, Terminal, Chemical Dispenser, 2 Pole
N/S	091-5010	1	Block, Terminal, 6 Pole (White Wires)
N/S	291-5106	1	Block, Terminal, 6 Pole (Black Wires)
N/S	289-0001	1	Nameplate, ADS
N/S	289-6617	1	Gasket Material, Control Box, 78" (Cut from 289-6615)
N/S	289-9204	1	Decal, NSF (244 Racks)
N/S	289-9301	1	Wall Chart, Cleaning, ADS
N/S	289-9209	1	Decal, Wiring Diagram
N/S	291-9108	3	Shield for Contactor Overload (Anti-Tamper)
N/S	096-1002	1	Control Box Lock
N/S	096-1008	1	Control Box Dummy Lock
N/S	091-4152	1	Bell Box
N/S	091-4004	1	Bell Box Cover
N/S	286-6181	1	Bracket, Conduit (Rear of Machine)
N/S	289-9201	1	Decal, Label Set (Blue & Gray) (Temp. Gauge Bracket)
N/S	289-9202	1	Decal, Label Set (Yellow & Black, Inside Control Box)
N/S	289-9206	1	Decal, Temp Gauge, Final Rinse, 180°
N/S	289-9217	Rep.	Decal Set, ADC-44 (Replacement Part)
N/S	299-1010	Rep:	Temp Gauge Cover, Screw-On
N/S	288-1044	Opt.	Kit, Table Limit Switch
N/S	288-1077	Opt.	Kit, Table Limit, For Sheet Pan Racks
N/S	291-3015	Opt.	Switch Only, Table Limit
N/S	291-5107	Opt.	Wire Harness, 1 Phase
N/S	288-1071	Opt.	Kit, Drain Water Tempering
N/S	388-1007	Opt.	Kit, Vent Fan "Signal Only"

Control System Assembly

ADC-44 L-R Tall

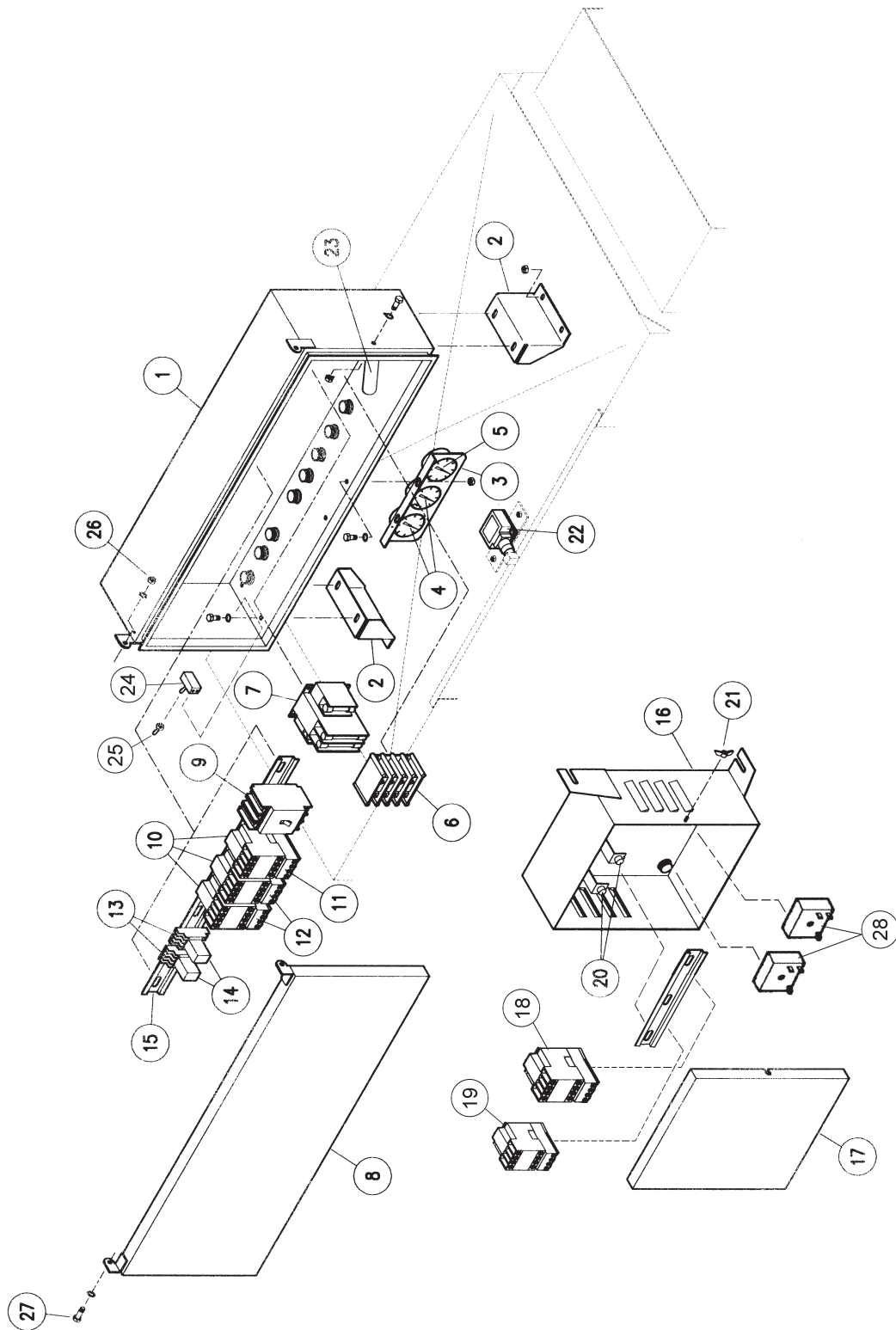

Water Inlet Assembly

ADC-44 L-R Tall

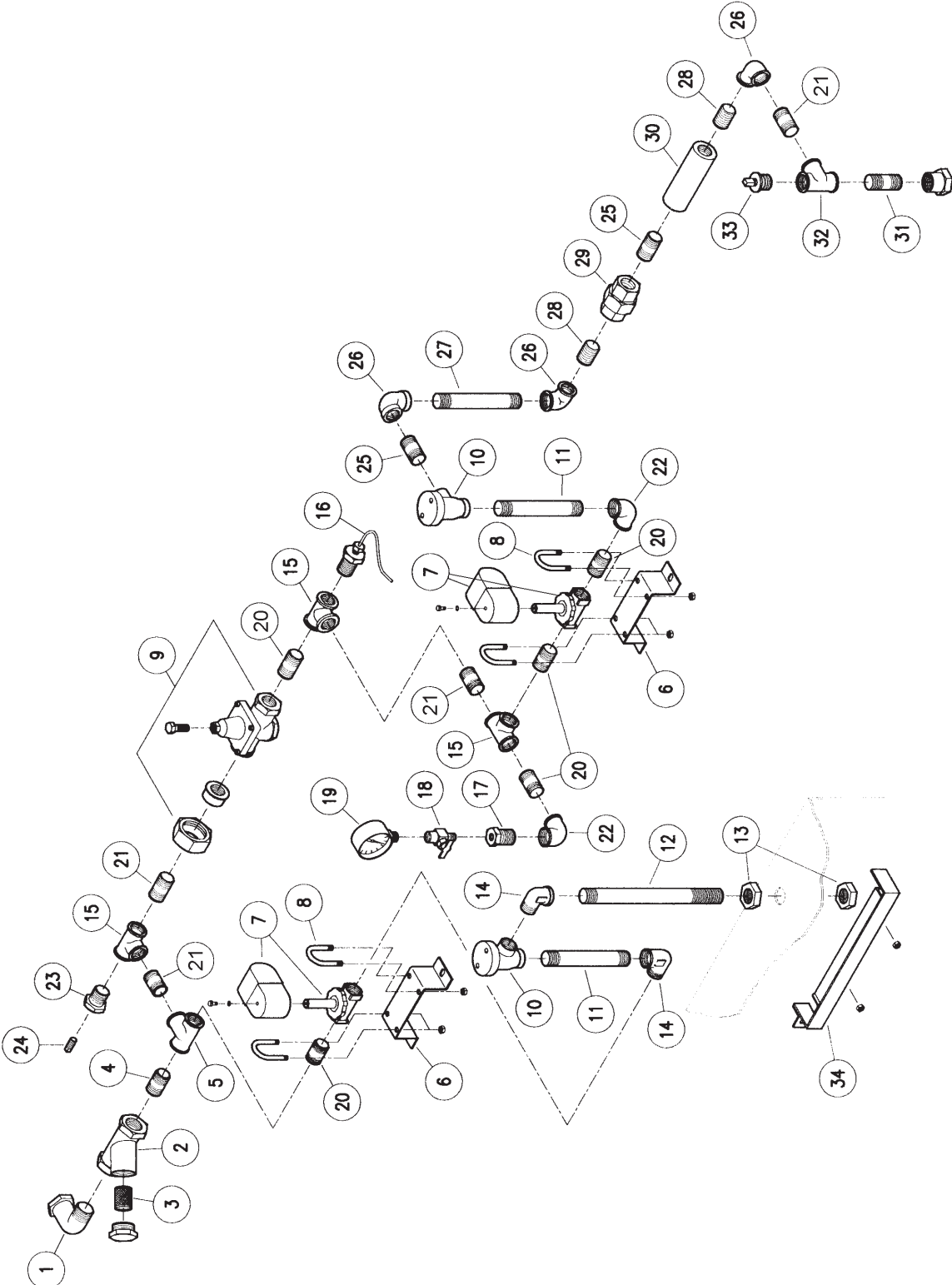

Water Inlet Assembly

ADC-44 L-R Tall

Ref. No.	Part No.	No. Req.	Description
1	092-1074	1	Fitting, 3/4" Street Elbow, 90°
2	092-9006	1	Y-Line Strainer, 3/4"
3	092-9008	Rep	Line Strainer Screen, 3/4"
4	092-1073	1	Nipple, 3/4" Close, Brass
5	092-1107	1	Tee, 3/4" x 1/2" x 1/2" Brass
6	286-6191	2	Bracket, Plumbing
7	092-5015	2	Valve, Water Solenoid, 1/2", 110 Volt
8	098-9027	4	Bolt, 'U', 1/4"-20
9	292-5007	1	Pressure Regulator, 1/2"
10	092-5045	2	Vacuum Breaker, 1/2"
11	292-3008	2	Nipple, 1/2" x 6" Lg, SS
12	292-3006	1	Nipple, 1/2" x 9-1/2" Lg, SS
13	292-1006	2	Pipe Locknut, 1/2" FPT, Brass
14	092-1006	2	Elbow, 1/2" Street, 90°
15	292-1002	3	Tee, 1/2" x 1/2" x 1/2", SS
16	299-1004	1	Temperature Gauge, Final Rinse, 3' Capillary
17	299-1005	2	Gauge, Temp., Wash/Rinse Tanks
18	292-5002	1	Service Cock
19	299-1003	1	Pressure Gauge
20	292-3001	5	Nipple, 1/2" x 1-1/2" Lg, SS
21	292-3014	4	Nipple, 1/2" x 2" Lg, SS
22	292-1003	2	Fitting, 1/2" Elbow, 90°, SS
23	292-1007	1	Reducer Bushing, 1/2" MPT x 1/8" FPT
24	092-1145	1	Plug, 1/8" MPT, SS
25	292-3001	2	Nipple, 1/2" x 1-1/2" Lg, SS
26	292-1003	3	Fitting, Elbow, 1/2" FPT, SS
27	292-3008	1	Nipple, 1/2" x 6" Lg, SS
28	292-3003	2	Nipple, 1/2" x Close, SS
29	292-1004	1	Union, 1/2", SS
30A	284-6148	1	Mixing Chamber, SS
30B	284-6147	Opt.	Mixing Chamber, Polymer
31	292-3010	1	Nipple, 1/2" x 3" Lg, SS
32	292-1002	1	Tee, 1/2" x 1/2" x 1/2", SS

Water Inlet Assembly

ADC-44 L-R Tall

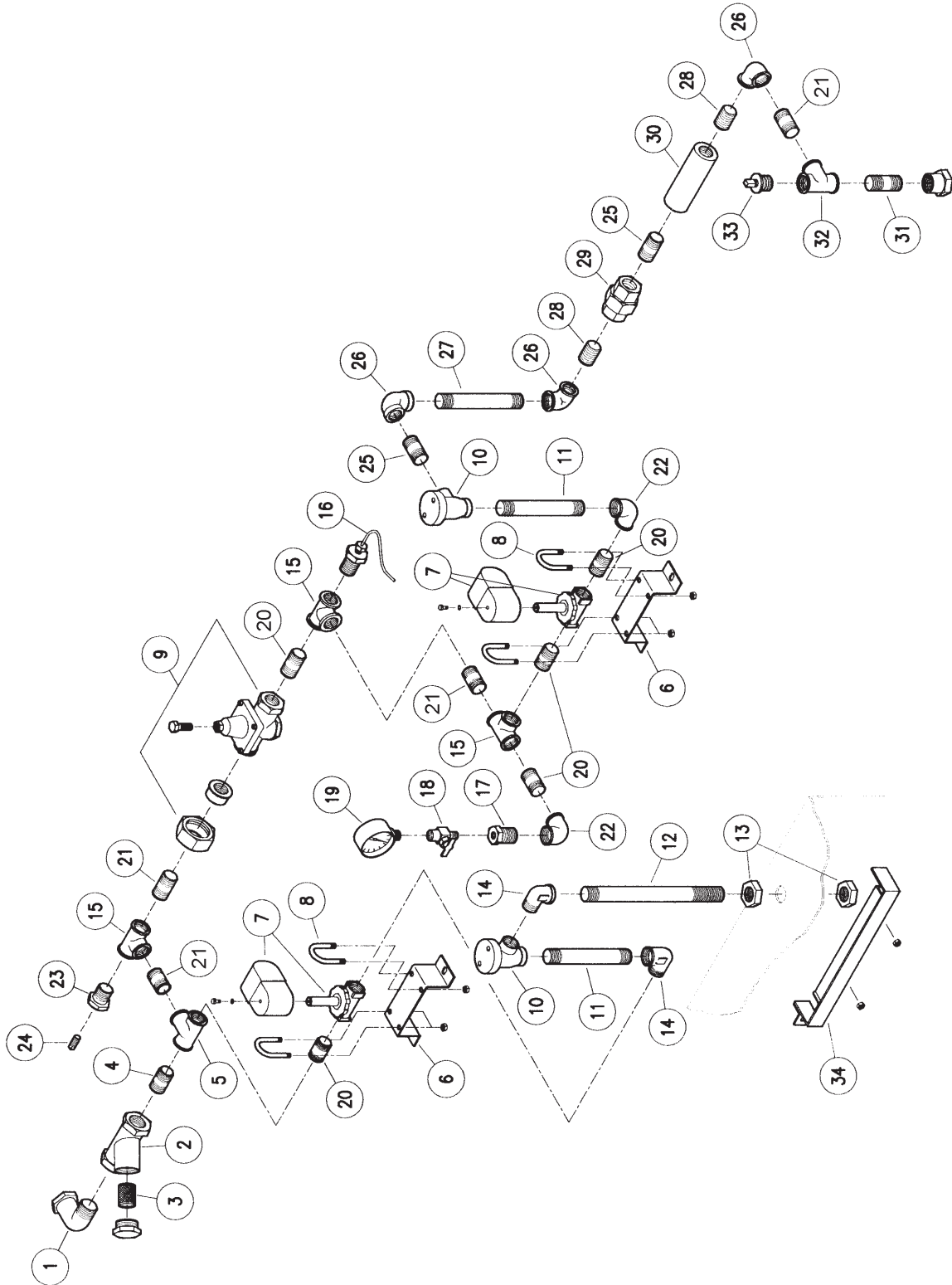

Heater & Water Level Control

ADC-44 L-R Tall

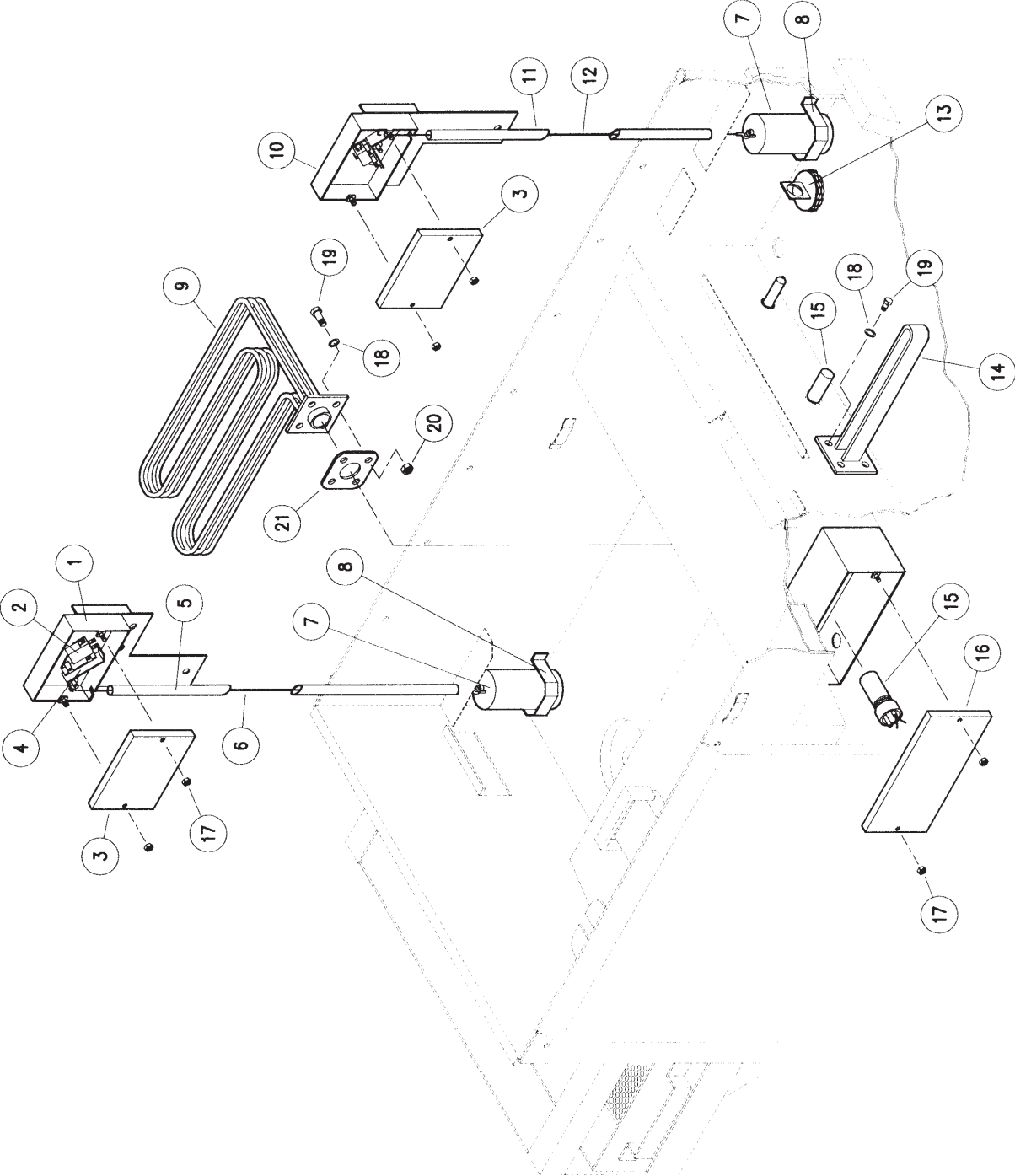

Heater & Water Level Control

ADC-44 L-R Tall

Ref. No.	Part No.	No. Req.	Description
1	285-6177	1	Float Box Weldment, LH
2A	291-3014	2	Float Switch, w/Holder & Button
2B	291-3013		Float Switch, Switch Only
2C	291-9109		Float Switch Holder
2D	291-9110		Float Switch Holder Button
3	285-6295	2	Float Box Cover
4	285-6179	2	Float Switch Flipper Weldment
5	285-6271	1	Float Rod Tube Weldment, Wash, L-R
6	286-6310	1	Float Rod, Wash
7	285-6176	2	Float Weldment
8	286-6199	2	Bracket, Float Retainer
9A	291-9009		Heater, Wash, 12KW, 208Volt, 3 Phase (Must Specify)
9B	291-9019		Heater, Wash, 11.5KW, 240 Volt, 1 Phase (Must Specify)
10	285-6178	1	Float Box Weldment, RH
11	285-6148	1	Float Rod Tube Weldment Rinse, R-L
12	286-6248	1	Float Rod Rinse
13	285-6162	1	Filter Weldment, Pumped Rinse Pump
14A	291-9003	1	Heater, Rinse, 2.25KW, 3 Phase, 208v
14B	291-9004	1	Heater, Rinse, 2.25KW, 1 Phase, 240v
15	291-3012	2	Thermostat
16	285-6292	2	Heater Box Cover
17	098-2201	8	Locknut, 8-32, SS
18	098-2510	16	Washer, 5/16", SS Neobond
19	098-1516	8	Bolt, 5/16"-18 x 1" LG HH, SS
20	098-2501	8	Locknut, 5/16"-18
21	289-6613	2	Gasket, Heater
N/S	286-6231	2	Flange, Heater Sandwich (1-1/2" Hole)
N/S	286-6241	4	Washer, Float Switch Rod, 3/4" OD x 1/8" ID, SS
N/S	098-1106	2	Screw, 6-32 x 1-1/8" Pan Head, SS (Per float Switch)
N/S	098-2101	2	Nut, 6-32, HH, SS (Per Float Switch)
N/S	291-5108	Rep.	Wire Harness, Heater, Wash/Rinse 3 Phase
N/S	291-5112	Rep.	Wire Harness, Heater, Wash/Rinse 1 Phase

Heater & Water Level Control

ADC-44 L-R Tall

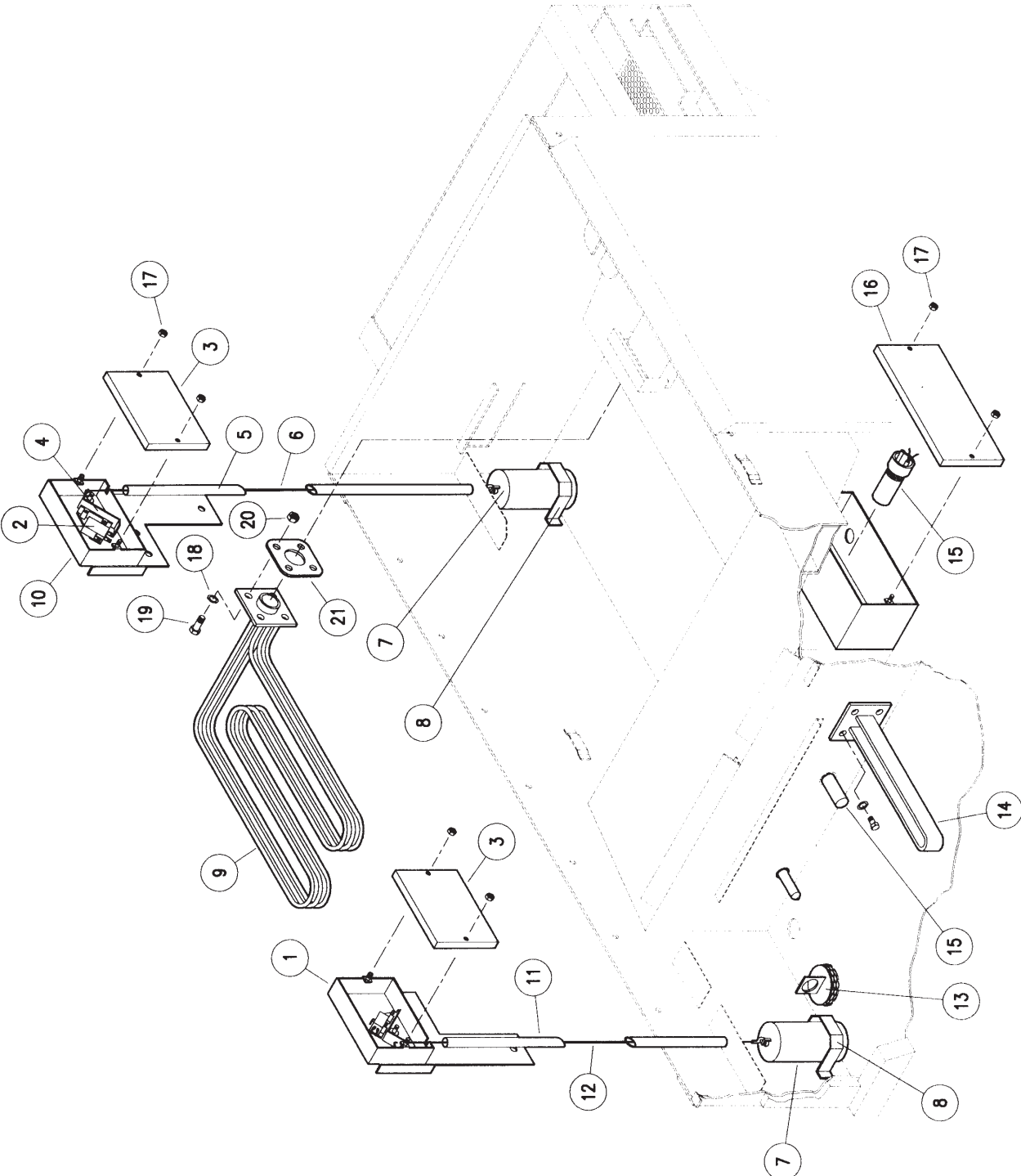

Heater & Water Level Control

ADC-44 L-R Tall

Ref. No.	Part No.	No. Req.	Description
1	285-6177	1	Float Box Weldment, LH
2A	291-3014	2	Float Switch, w/Holder & Button
2B	291-3013		Float Switch, Switch Only
2C	291-9109		Float Switch Holder
2D	291-9110		Float Switch Holder Button
3	285-6295	2	Float Box Cover
4	285-6179	2	Float Switch Flipper Weldment
5	285-6272	1	Float Rod Tube Weldment, Wash, R-L
6	286-6310	1	Float Rod, Wash, Tall
7	285-6176	2	Float Weldment
8	286-6199	2	Bracket, Float Retainer
9A	291-9009		Heater, Wash, 12KW, 208 Volt, 3 Phase (Must Specify)
9B	291-9019		Heater, Wash, 11.5KW, 240 Volt, 1 Phase (Must Specify)
10	285-6178	1	Float Box Weldment, RH
11	285-6180	1	Float Rod Tube Weldment Rinse, R-L (uses standard wash L-R)
12	286-6248	1	Float Rod Rinse
13	285-6162	1	Filter Weldment, Pumped Rinse Pump
14A	291-9003	1	Heater, Rinse, 2.25KW, 3 Phase, 208v
14B	291-9004	1	Heater, Rinse, 2.25KW, 1 Phase, 240v
15	291-3012	2	Thermostat
16	285-6292	2	Heater Box Cover
17	098-2201	8	Locknut, 8-32, SS
18	098-2510	16	Washer, 5/16", SS Neobond
19	098-1516	8	Bolt, 5/16"-18 x 1" LG HH, SS
20	098-2501	8	Locknut, 5/16"-18
21	289-6613	2	Gasket, Heater
N/S	286-6231	2	Flange, Heater Sandwich (1-1/2" Hole)
N/S	286-6241	4	Washer, Float Switch Rod, 3/4" OD x 1/8" ID, SS
N/S	098-1106	2	Screw, 6-32 x 1-1/8" Pan Head, SS (Per float Switch)
N/S	098-2101	2	Nut, 6-32, HH, SS (Per Float Switch)
N/S	291-5108	Rep.	Wire Harness, Heater, Wash/Rinse, 3 Phase
N/S	291-5112	Rep.	Wire Harness, Heater, Wash/Rinse, 1 Phase

Drain System Assembly

ADC-44 L-R Tall

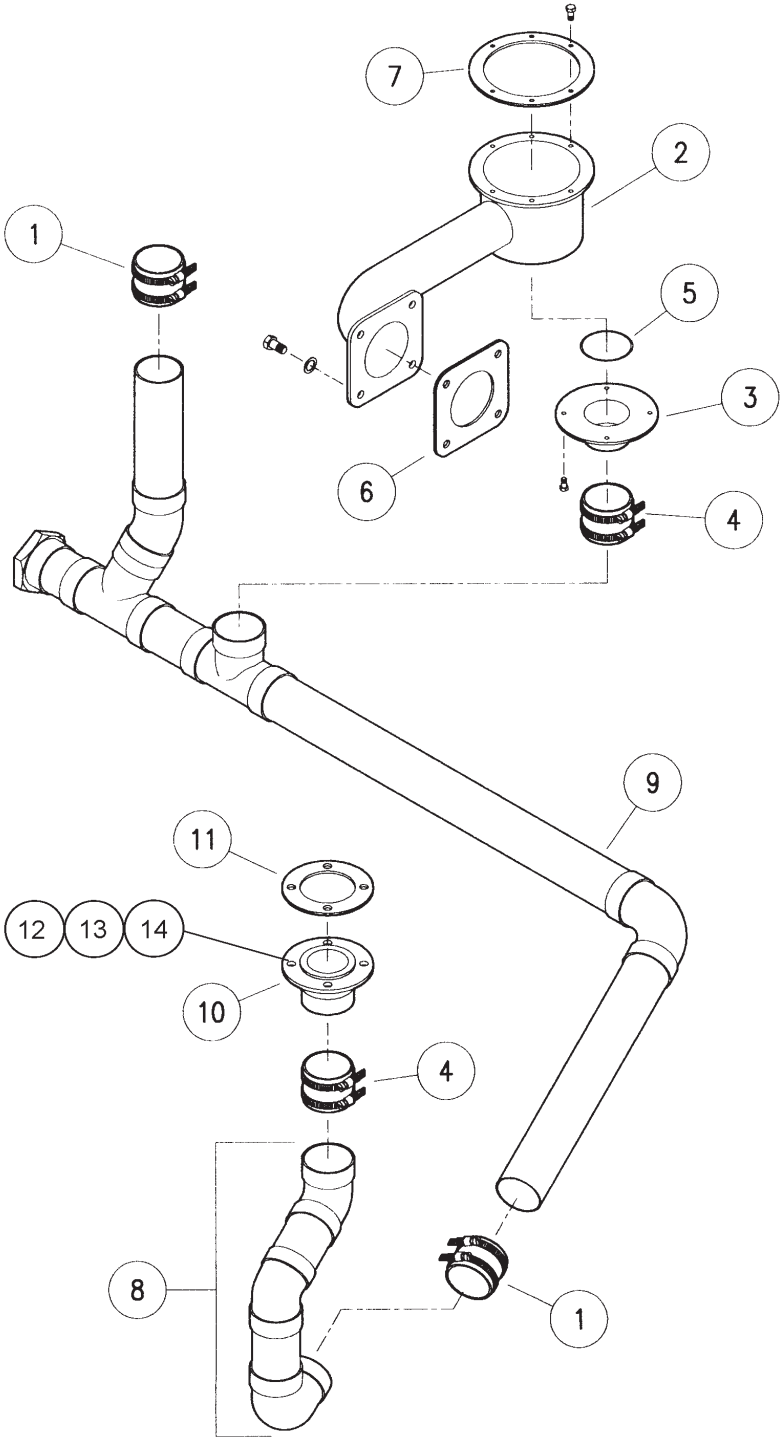

American Dish Service

**Manufacturer of low and high temperature Commercial
Dishwashers and Glasswashers**

900 Blake Street | Edwardsville, Kansas 66111
Phone: 913.422.3700 | Toll-Free: 800.922.2178 | Fax: 913.422.6630
orders@americandish.com | americandish.com



an Ali Group Company



The Spirit of Excellence